

## Gear Motors

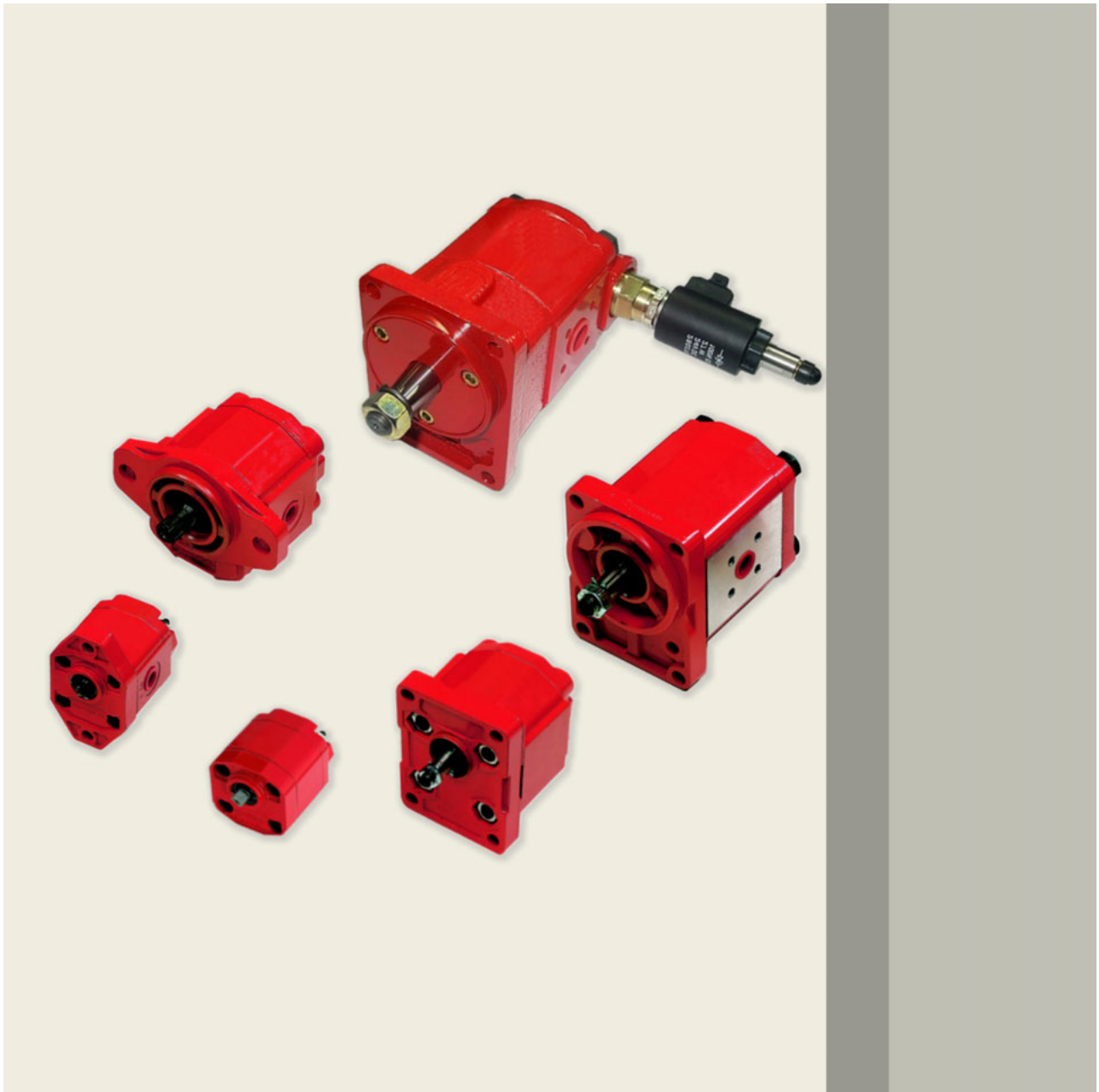

motion and progress

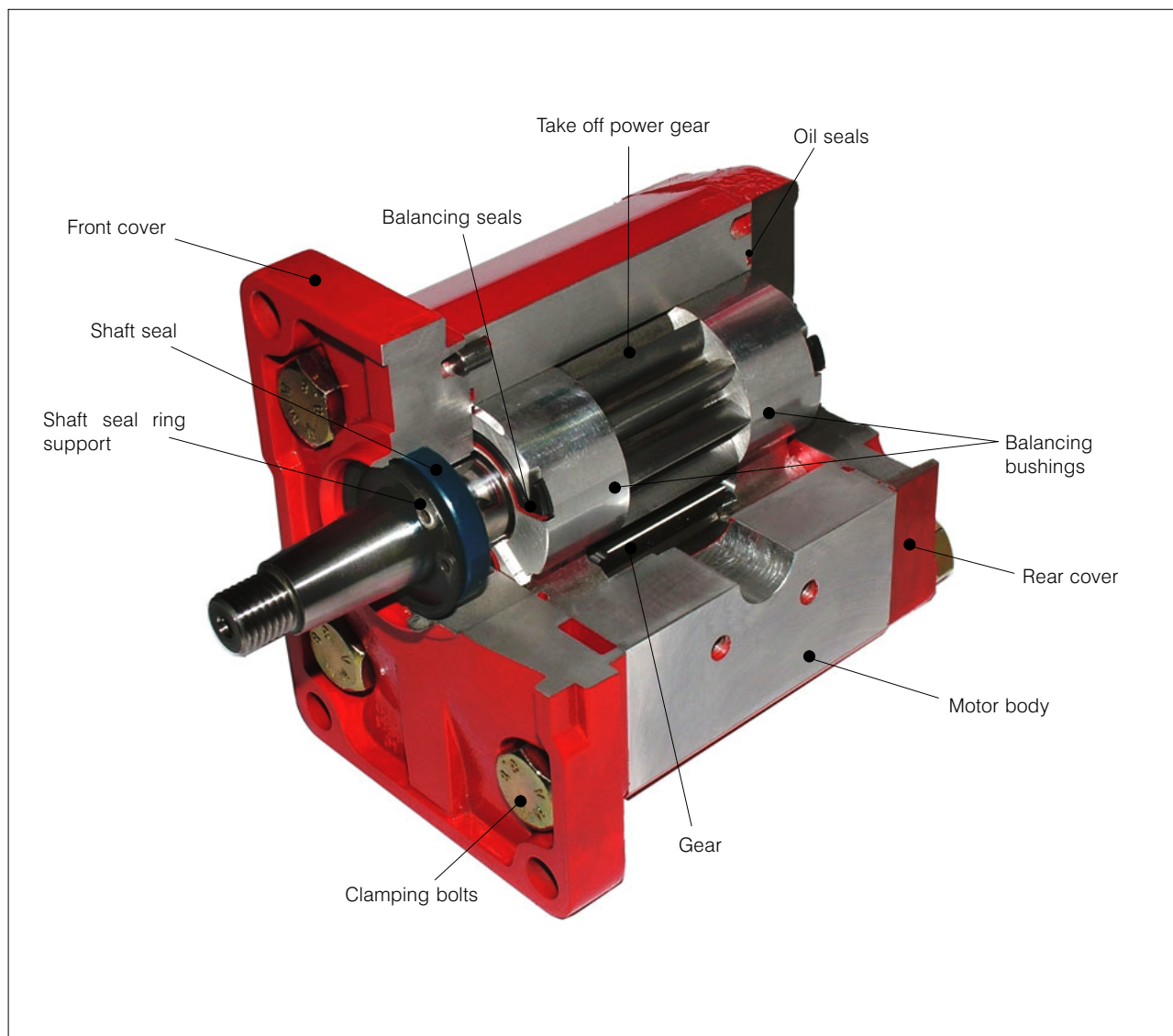

## Contents

1	General information	3
2	Technical information	4
3	Gear motors group APM05	16
4	Gear motors group APM100	25
5	Gear motors group APM200 - APMR200 - APFM200	38
6	Accessories	60
7	Composition of product code	61

## 1 General information

### 1.1 Introduction to the product

Gear motors are widely used in modern hydraulic systems due to their high performance, long service life, and low purchase and maintenance costs.

Product development has made it possible to achieve high operating pressures, excellent volumetric and mechanical efficiency, and lower noise levels, in operation, by means of:

- meticulous CAD design of the gear teeth and balancing areas
- an exacting choice of high-performance materials
- carefully controlled heat treatments

- increasingly tight coupling tolerances, and a high standard of surface finish.

- dedicated first running in cycle for motors specifically set up Bucher Hydraulics S.p.A. has achieved these results by constantly improving its design, control, and manufacturing techniques in line with the latest technological developments, while simultaneously introducing a Quality Control System which ensures that every single product offers the same high standards.

#### Product description

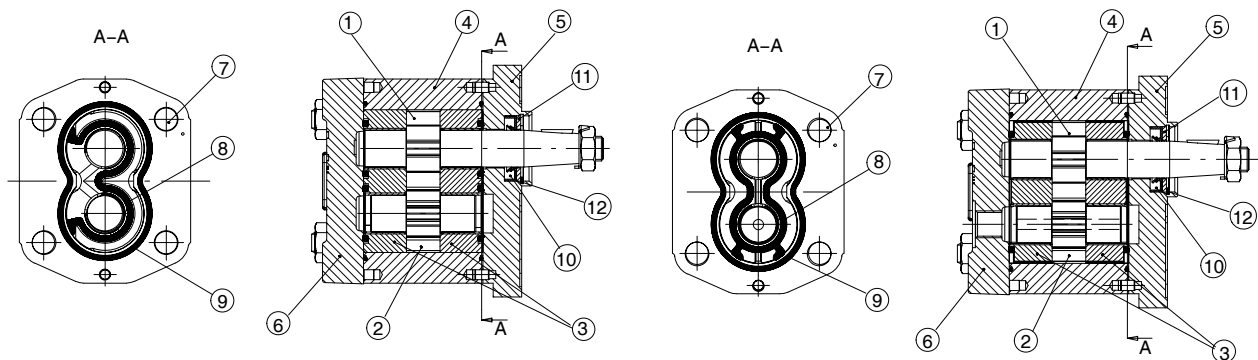

- 1 - Take off power gear
- 2 - Gear
- 3 - Balancing bushings
- 4 - Motor body
- 5 - Front cover
- 6 - Rear cover

- 7 - Clamping bolts
- 8 - Pressure balancing seals
- 9 - Oil seals
- 10 - Shaft seal
- 11 - Shaft seal ring support
- 12 - Seeger elastic ring

Referring to the motor shown in the figure, feeding pressurised oil ( $Q - \Delta p$ ) into the inlet port of the motor, the gear 1 and 2 turn, and power, as torque and speed ( $M - n$ ) can be obtained at the output shaft end.

The gears are made from high strength steel alloy.

The bushings (3) serve a dual purpose:

- to act as a bearing for the gears
- to balance axial and radial thrust in proportion to the change in operating pressure.

The gears-bushings assembly is fitted inside the motor body (4), in which generally the inlet and outlet ports are formed. The motor body is made of high strength extruded aluminium alloy. The front cover (5), which also acts as a mounting flange, and the rear cover (6) are connected to one another by clamping bolts (7).

The motor assembly is completed by a series of seals:

- Balancing seals (8) can be fitted in recesses in the bushings as shown in the figure, or in the covers. Their purpose is to delimit the longitudinal balancing area separating the high and low pressure zones.
- Oil seals (9) prevent oil from leaking out.
- A shaft seal with a steel supporting ring (11) locked by a seeger elastic ring (12) purpose of preventing oil leaks

from the gear shaft end and preventing dust or other pollutants from entering the motor itself. Unless otherwise specified, the seals are nitrile NBR compound offering high mechanical strength and heat resistance.

Viton FKM seals are available on request.

(see 2.2 Recommended fluids/Allowed temperatures)

#### Versions available

The Bucher Hydraulics S.p.A. product range includes motors of groups APM05-APM100-APM200 (corresponding to the common group denominations: 05-1-2).

For front flange, shaft- end and inlet-outlet versions, motors are available in many and different European, American and special customised configurations. Moreover motors of the groups 05 and 2 are also available in the reversible rotating version with external threaded drain port. For the group 2, the version with internal drain connection, which does not require any hose, is also available.

Bucher Hydraulics S.p.A. will examine any request for special versions, features, and customisations not shown in this catalogue. To make such a request, please contact our Sales Department.

## 1.2 Non-standard symbols used in the text



Check nut

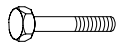

Hexagonal-head screw  
( TE screw)



O-Ring



Lock washer

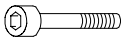

Socket head screw  
(TCE screw)



Woodruff key

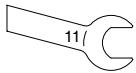

Dynamometric  
spanners

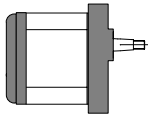

Version with front and rear  
cover in cast iron,  
available



Square key

## 2 Technical information

### 2.1 Identifying the rotation direction

The rotation direction of a gear motor is identified by looking at the motor from the front and with the take off shaft turned upwards (see figures below).

Motors with clockwise rotation (D) have a take off shaft which turns clockwise, with the inlet port on the left and the outlet port on the right.

Motors with counterclockwise rotation (S) have a take off shaft which turns counterclockwise, with the inlet port on the right and the outlet port on the left.

The figure also shows the pressure flow inside the motors as the oil is transferred from the inlet port to the outlet port.

As regards reversible motors (R), the ports are alternatively

for high and low pressure.

Motors with a unidirectional rotation (D or S) have the denomination APM. Motors with reversible rotation have the denomination APMR.

It is possible to change the rotation direction of the entire range of motors without having to replace any component, except for the APM100 group, for which it is necessary to replace the front cover.

To ensure a good technical result, we recommend in any case that such inversion be carried out at our factory.

Technical descriptions are available on request, which show the correct procedure for the motor rotation inversion.

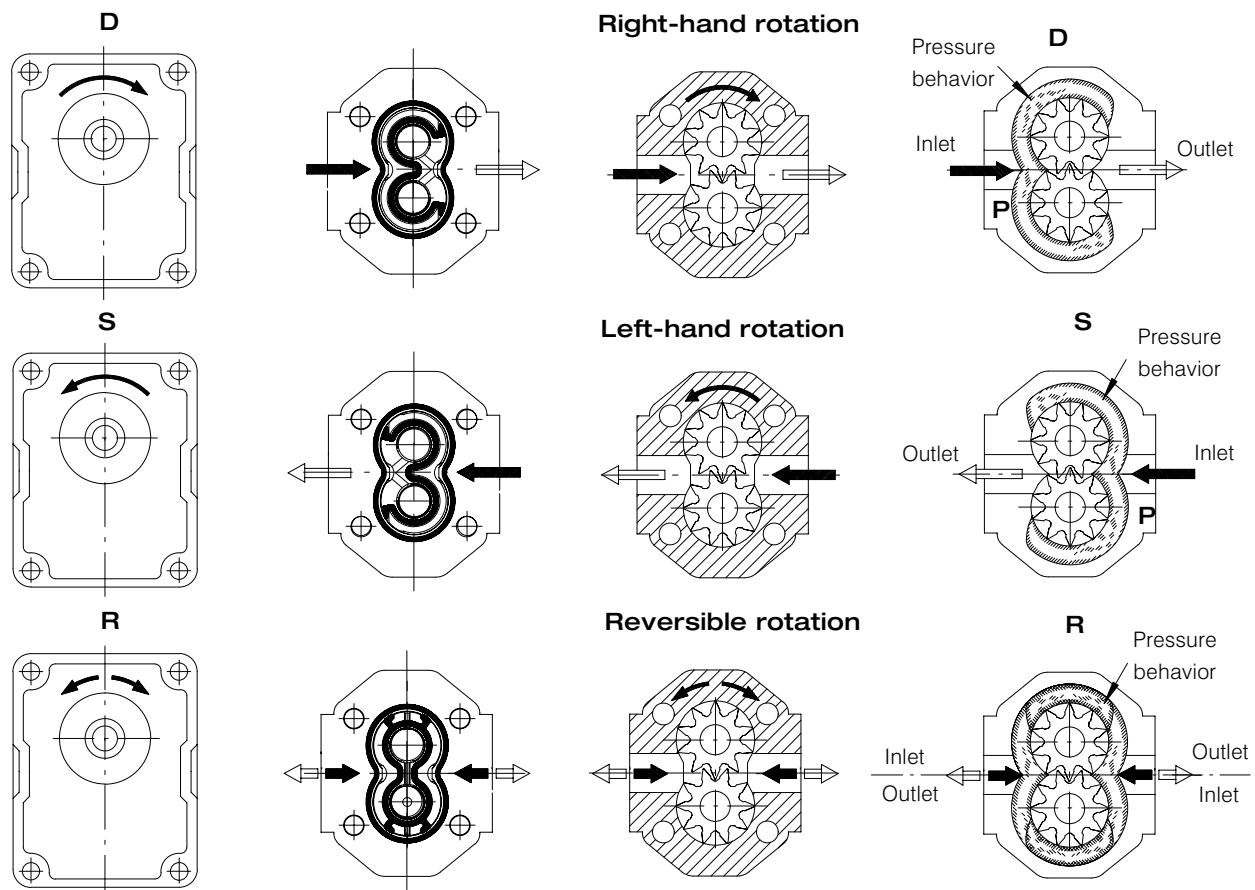

## 2.2 Recommended fluids/Allowed temperatures

We recommend using only mineral oil-based hydraulic fluids that comply with the ISO/DIN standards.

Viscosity range: recommended **20 + 120 mm<sup>2</sup>/s (cSt)**  
permitted up to **700 mm<sup>2</sup>/s (cSt)**

Operating temperature

Type of seals	Temperature	
	APM05	APM100 APM200-APMR200
Buna N	-15 ÷ 65° C	-15 ÷ 80° C
Viton*	-10 ÷ 80° C	-10 ÷ 120° C

**\* Caution! – Use of motors at temperatures above 80°C must always be agreed upon with our Technical Office, and in any case this can cause a significant worsening in the volumetric efficiency.**

**For use under conditions different from those indicated in this catalogue, please contact our Sales Department.**

## 2.3 Outlet

### 2.3.1 Unidirectional motors

As a matter of principle, unidirectional motors correspond to counter rotating pumps. The balancing seals are not symmetric and, consequently, two different pressure sides: inlet High-pressure and outlet Low-pressure side, which must not be exchanged each other, are defined. The outlet Low-pressure side loads the back side of the oil retaining shaft seal, a dedicated steel ring for supporting it, is adopted. The maximum outlet Low-pressure value is limited by the shaft seal and its support and it must be **M1 ≤ 3.5 bar (50 PSI)**, although the real value is related to the shaft speed: for detailed information, please, contact our Sales Dept.

To keep P out below the suggested value, the following must be avoided:

- long distance between motor and tank
- long stretches of piping
- special features such as: bends; reductions in diameter; quick couplings; etc.

Having filtration on the return it is also advisable to choose a filter of a suitable size to minimise any pressure drop and to take measures to prevent gradual clogging over time.

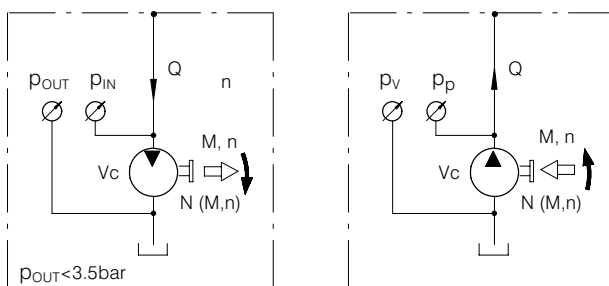

### 2.3.2 Reversible motors

Reversible rotating motors have symmetric balancing seals and both port, inlet and outlet, can be, alternatively, operate as inlet High-pressure and outlet Low-pressure port. A sealed area is connected to the back side of the oil retaining shaft seal and its pressure must be limited connecting it to the tank, through a drain threaded port, which is generally, placed on the motor rear cover.

The drain hose must be chosen in order to avoid that the pressure at the drain port does not exceed 3,5 bar.

Motors with internal drain connection, are available, but adopting this solution the outlet Low-pressure side must be ≤ 3,5 bar.

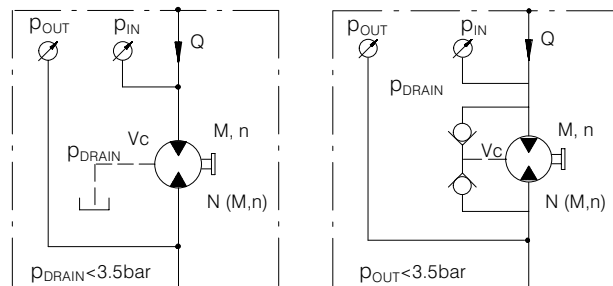

## 2.4 Filtration

A short service life of a gear motor is normally due to the presence of impurities in the oil.

It is therefore essential to have an effective filter in the system and to carry out regular maintenance to ensure a long, trouble-free service life.

When possible and compatible with the hydraulic circuit installed, Bucher Hydraulics S.p.A. recommends that the system have total filtration (high and low pressure, return). In any case, the filtering system must constantly ensure an oil contamination class equal to or less than those shown in the following table.

Operating pressure	> 170 bar 2430 PSI	< 170 bar 2430 PSI
Contamination class NAS 1638	9	10
Contamination class ISO 4406	18/15	19/16
Obtain with filter $\beta_x = 75$	20	25

We also recommend that an adequate air filter be installed on the tank to prevent contaminating substances such as dust, sand, etc. from getting into the oil, as these substances can enter the tank through the air flow caused by the level variations in the tank itself.

## 2.5 Gear Motor-driven unit Coupling

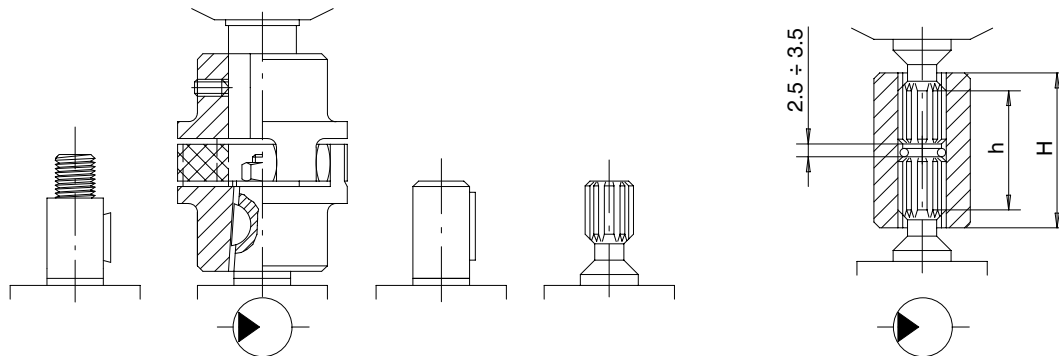

Absolutely no radial or axial forces should be transmitted to the motor shaft in the gear motor-driven unit coupling. Such forces cause rapid and irregular wear on the balancing surface of the bushings and gear supports, with a consequent worsening in motor performance. The coupling joint must be able to absorb any discrepancies in the coaxial alignment of the gear motor-driven unit shafts without placing any load on the motor shaft. In the couplings between splined shafts, the connecting sleeve must be free to move along its axis. The length of the sleeve must be sufficient to cover the splined sections of the gear motor-driven unit shafts completely in any position.

The distance between the ends of the shafts must be between **2.5 ÷ 3.5 mm (.10" ÷ .14")**. Make sure that the splined coupling is suitably lubricated to protect it against rapid deterioration. If there are radial and/or axial loads on the take off shaft, such as when it is coupled to a V-belt and pulley or pair of gear wheels, it should be fitted with a front cover with supporting bearings. (See examples 1 and 2) Depending on the motor model concerned, these supports can replace the front cover of the motor (e.g. 201 K8 and 201 K0) or can be fitted in addition to and over the front cover.

(Example 1)

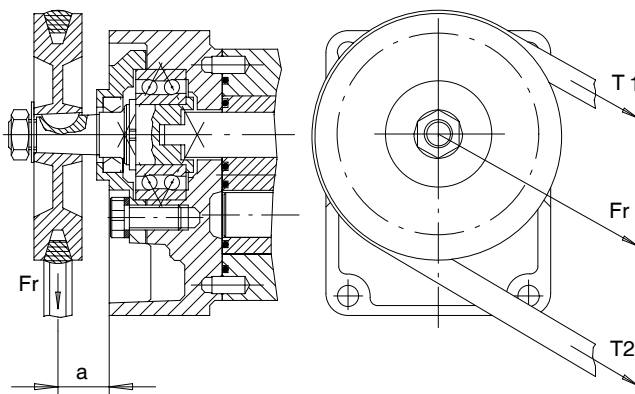

(Example 2)

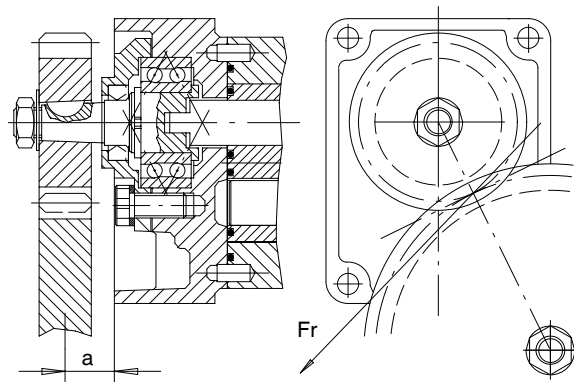

The allowed radial load values "Fr" in relation to "a" are shown in the diagrams of each version equipped with cover with support bearings.

## 2.6 General installation precautions

In addition to the recommendations regarding fluids, filtration, coupling, etc., we suggest the following:

- For unidirectional motors check always the rotation direction of the motor's take off shaft; it must be compatible with the rotation direction of the motor itself.
- Be particularly careful in cleaning and make sure, when connecting the high and low pressure piping, that no chips, rag threads, teflon tape, etc. get into the motor circulation system.
- Check the tightness of the high and low pressure fittings, the correct positioning of the O-Ring, and make sure there is no dirt between the flange and the motor body.
- To ensure the best heat distribution inside the tank, make sure the return pipe is not too close to the pump's suction piping.

The pipes themselves should be below oil tank level to prevent the formation of foam.

- Do not subject the motors to operating conditions different from those indicated on section 2.8; for extreme operations, always contact our Technical Department.
- Never use fluids different from those indicated in section 2.2.
- Ambient temperature range:  $-20 \div +50^{\circ}\text{C}$
- Any mounting position is allowed
- In the event of motor painting, do not use solvents or paints that are incompatible with the material of the seals. Do not bake paint with excessively high temperatures. Do not paint over the product identification plate; the warranty will not be valid if this plate is illegible.

## 2.6.1 Directives and standards

### - Atex:

The equipment and protective systems of these catalogue ARE NOT intended for use in potentially explosive atmospheres that is to say where there is an explosive atmosphere referred to in Article 2 of the Directive 99/92/EC and referred to Article 1.3 of the Directive 94/9/EC.

### - Machinery safety

Hydraulic motors are excluded by Directive 98/37/EC

### - ISO 9001: 2000

Bucher Hydraulics S.p.A. is certified for research, development and production of directional control valves, gear pumps and motors, power units, electro motors pumps, cartridge valves and integrated manifolds for hydraulic applications.

## 2.7 Calculating the specifications of a gear motor

The following parameters are defined:

**V<sub>c</sub>** = (cm<sup>3</sup>/r) motor displacement;

**n** = (r/min) no. of rpms of the outlet shaft;

**Q** = (l/min) flow rate;

**Δp** = (bar) P<sub>IN</sub>-P<sub>OUT</sub>, operating Δp pressure;

**M** = (Nm) outlet torque;

**N** = (kW) outlet power;

**η<sub>v</sub>** = (%) volumetric efficiency;

**η<sub>m</sub>** = (%) mechanical efficiency;

**η<sub>t</sub>** = (%) total efficiency (η<sub>t</sub> = η<sub>v</sub> · η<sub>m</sub>)

### 2.7.1 Parameter relationships

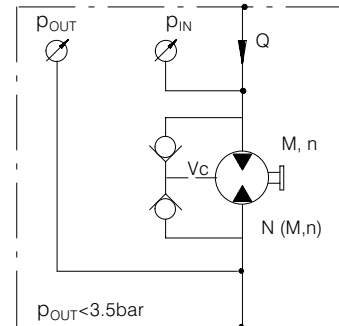
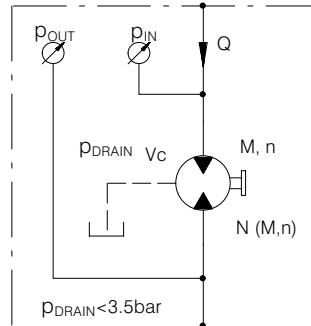
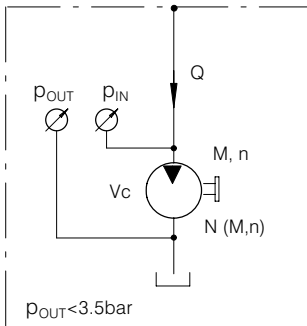
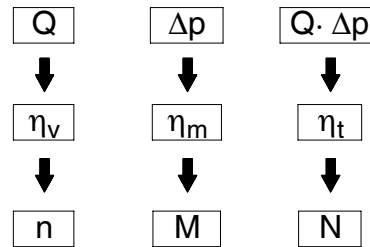

$$Q = \frac{V_c \cdot n}{10 \cdot \eta_v}$$

$$\Delta p = \frac{M}{1.592 \cdot V_c \cdot \eta_m} \cdot 10^4$$

$$V_c = \frac{10 \cdot Q}{n} \cdot \eta_v$$

$$V_c = 1.592 \cdot \frac{M}{\Delta p \cdot \eta_m} \cdot 10^4$$

$$n = \frac{10 \cdot Q}{V_c} \cdot \eta_v$$

$$M = 1.592 \cdot V_c \cdot \Delta p \cdot \eta_m \cdot 10^{-4}$$

$$N = \frac{Q \cdot \Delta p}{6.12 \cdot 10^4} \cdot \eta_t$$

### Example

APM100/2.5 V<sub>c</sub> = 2.5 cm<sup>3</sup>/r Q = 4 l/min Δp = 200 bar η<sub>v</sub> = 94% η<sub>m</sub> = 87%

$$n = \frac{10 \cdot 4}{2.5} \cdot 94 = 1500 \text{ r/min.}$$

$$\eta_t = 0.94 \cdot 0.87 = 0.82 = 82\%$$

$$N = \frac{4 \cdot 200 \cdot 82}{6.12 \cdot 10^4} = 1.07 \text{ kW}$$

$$M = 1.592 \cdot 2.5 \cdot 200 \cdot 87 \cdot 10^{-4} = 7 \text{ Nm}$$

## 2.8 High inlet pressure

Pressure levels:

p1 = continuous pressure

p2 = max. peak pressure

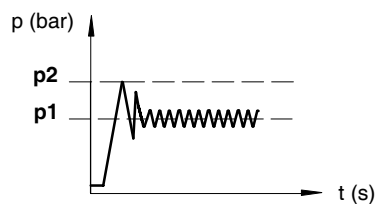

Application of motor operating at a high number of load cycles has to be submitted to our approval

APM05	Displacement		Max. pressure				n min.	n max.
	cm <sup>3</sup> /rev	Cu. In. P. R.	P1		P2			
			bar	P.S.I.	bar	P.S.I.	r/min	r/min
<b>APM05/0.5</b>	0.5	.030	190	2700	230	3300	800	7000
<b>APM05/0.75</b>	0.75	.045	190	2700	230	3300	800	7000
<b>APM05/0.9</b>	0.9	.055	190	2700	230	3300	800	7000
<b>APM05/1.2</b>	1.2	.073	170	2400	200	2900	700	6000
<b>APM05/1.6</b>	1.6	.097	170	2400	200	2900	700	6000

APM100	Displacement		Max. pressure				n min.	n max.
	cm <sup>3</sup> /rev	Cu. In. P. R.	P1		P2			
			bar	P.S.I.	bar	P.S.I.	r/min	r/min
<b>APM100/2.5</b>	2.5	.152	210	3000	280	4000	650	5000
<b>APM100/3.5</b>	3.5	.213	210	3000	250	3600	650	4000
<b>APM100/4.3</b>	4.3	.262	210	3000	250	3600	550	4000
<b>APM100/5</b>	5.0	.305	210	3000	250	3600	500	3500
<b>APM100/6.5</b>	6.5	.396	190	2700	240	3400	500	3000
<b>APM100/8</b>	7.8	.476	180	2600	230	3300	500	3000
<b>APM100/10</b>	10.0	.610	150	2150	200	2900	500	2500

APM200 Type	Displacement		Max. pressure				n min. r/min	n max. r/min
	cm <sup>3</sup> /rev	Cu. In. P. R.	P1		P2			
			bar	P.S.I.	bar	P.S.I.		
<b>APM200/8.5</b>	8.3	.506	220	3150	250	3600	650	4000
<b>APM200/11</b>	11.0	.671	210	3000	250	3600	650	4000
<b>APM200/15</b>	15.0	.915	210	3000	250	3600	650	3500
<b>APM200/19</b>	18.9	1.159	200	2900	240	3400	650	3000
<b>APM200/22</b>	21.9	1.342	190	2800	230	3300	600	3000
<b>APM200/26</b>	25.9	1.586	180	2600	220	3150	600	2500
<b>APFM200/8.5</b>	8.3	.506	220	3150	250	3600	650	4000
<b>APFM200/11</b>	11.0	.671	210	3000	250	3600	650	4000
<b>APFM200/15</b>	15.0	.915	210	3000	250	3600	650	3500
<b>APFM200/19</b>	18.9	1.159	200	2900	240	3400	650	3000
<b>APFM200/22</b>	21.9	1.342	190	2800	230	3300	600	3000
<b>APFM200/26</b>	25.9	1.586	180	2600	220	3150	600	2500
<b>APMR200/8.5</b>	8.3	.506	220	3150	250	3600	650	4000
<b>APMR200/11</b>	11.0	.671	210	3000	250	3600	650	4000
<b>APMR200/15</b>	15.0	.915	210	3000	250	3600	650	3500
<b>APMR200/19</b>	18.9	1.159	200	2900	240	3400	650	3000
<b>APMR200/22</b>	21.9	1.342	190	2800	230	3300	600	3000
<b>APMR200/26</b>	25.9	1.586	180	2600	220	3150	600	2500

**N.B.:** Please contact our Sales Department if even one of the operating limits indicated in the tables above (temperature, pressure, rpm) is exceeded, as well as in the case of two or more maximum values at the same time, or for applications with particularly heavy-duty cycles.

2.9 Diagrams

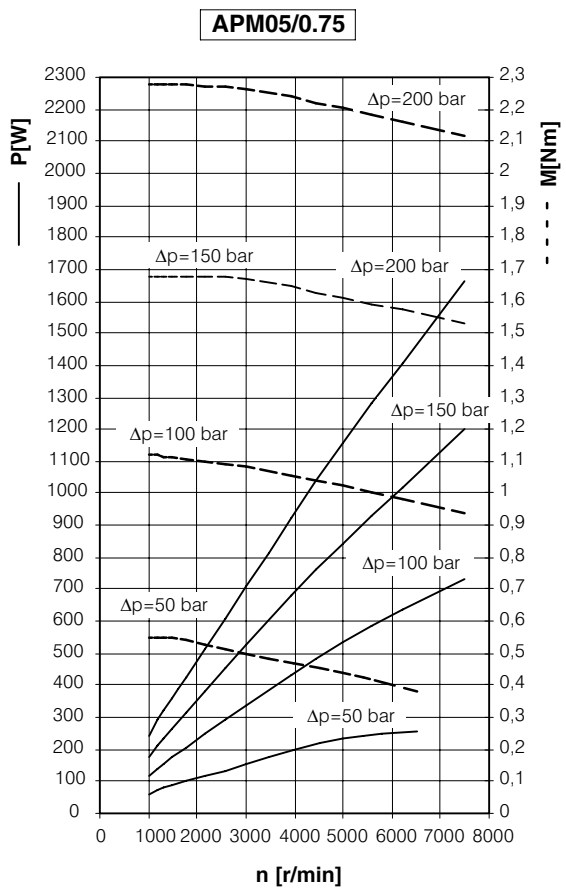
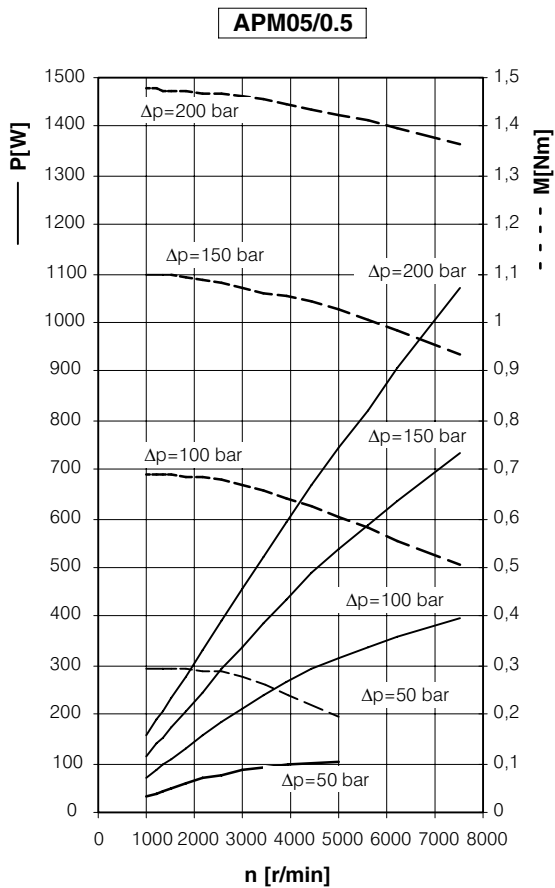
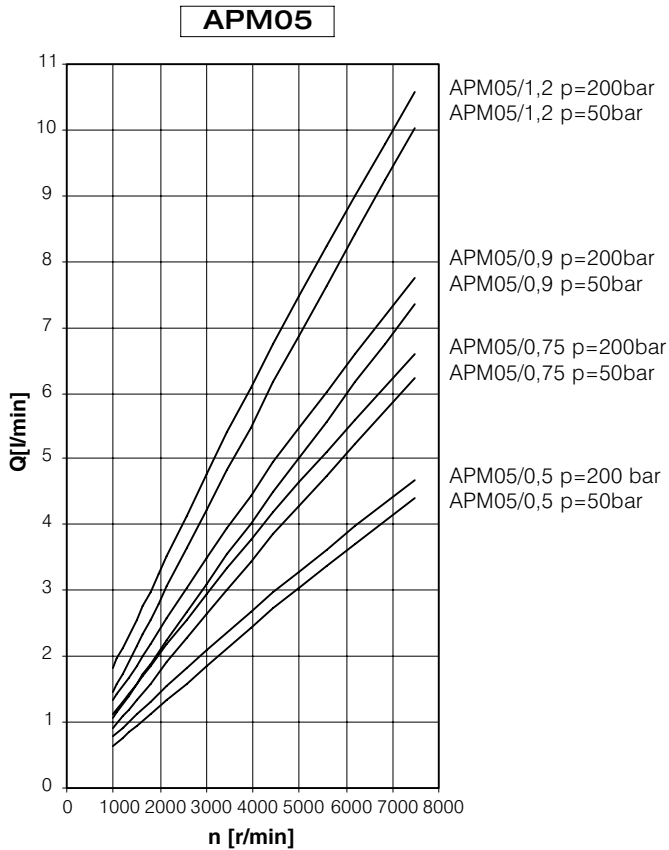

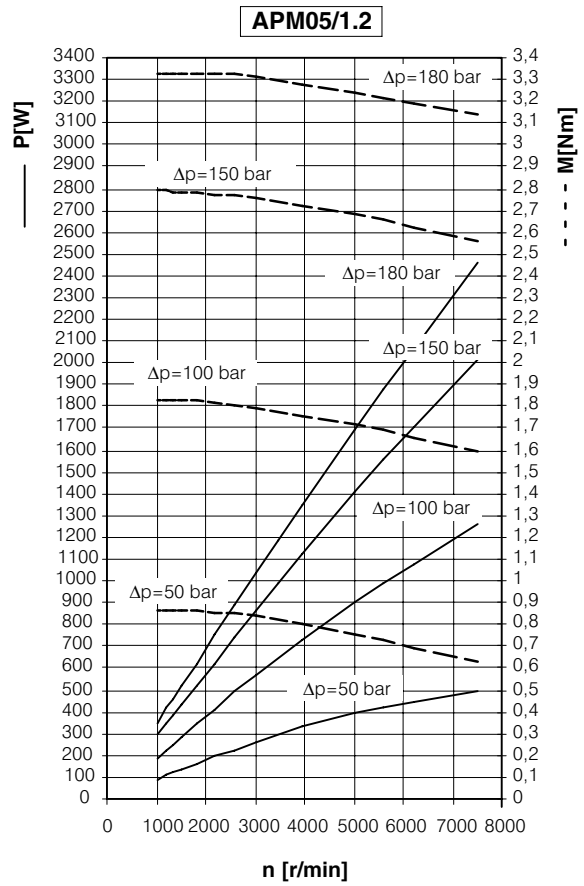
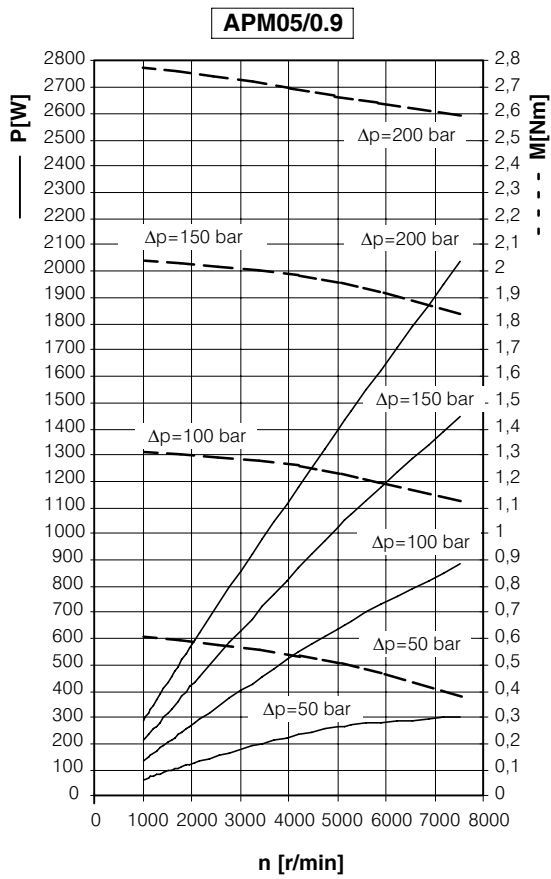

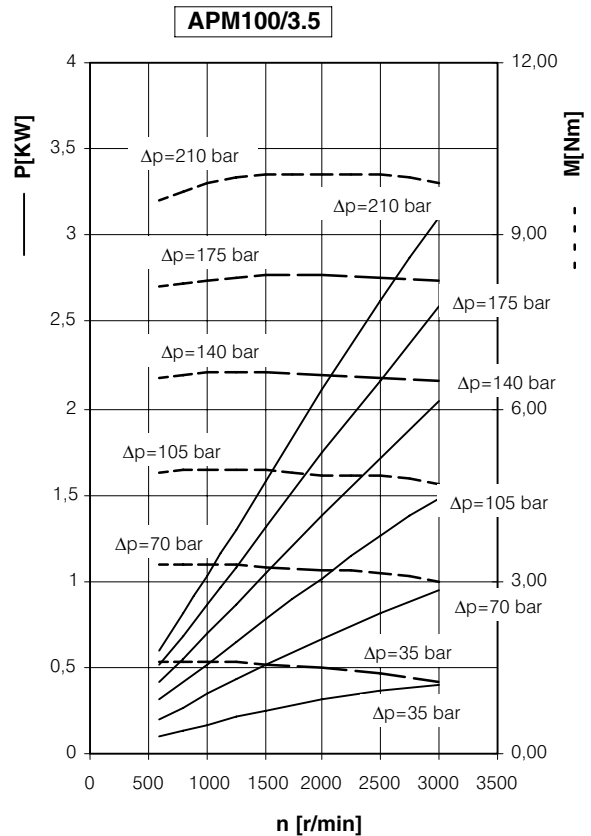
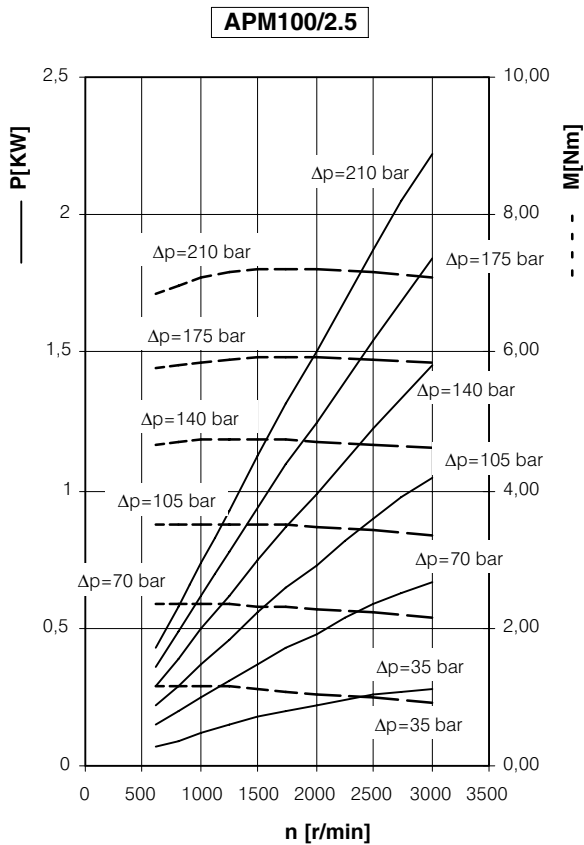
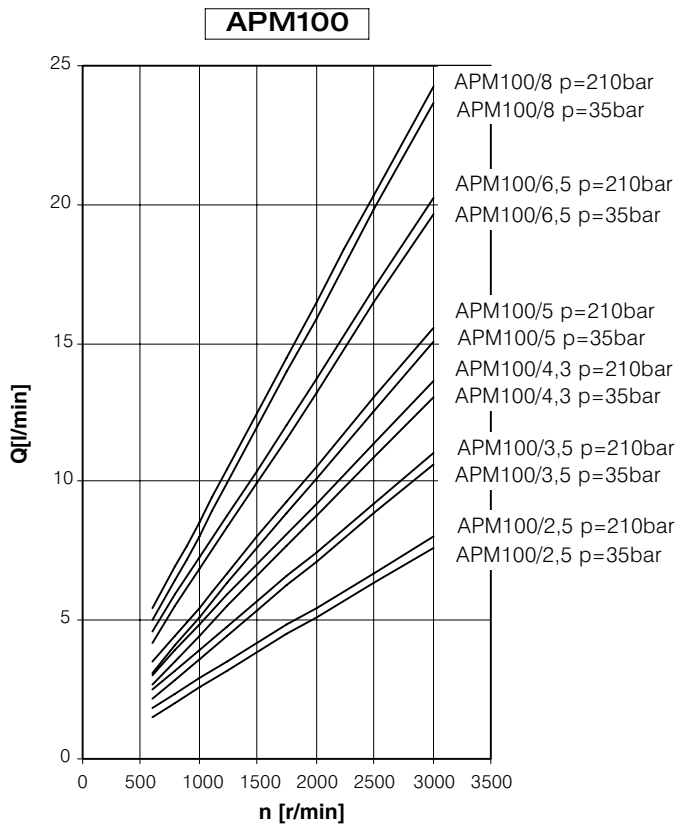

**APM100/4.3**

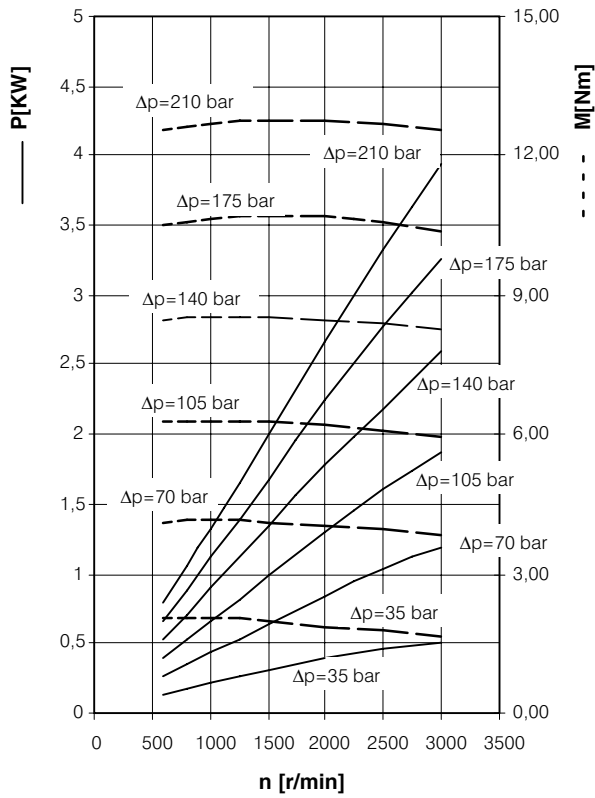

**APM100/5**

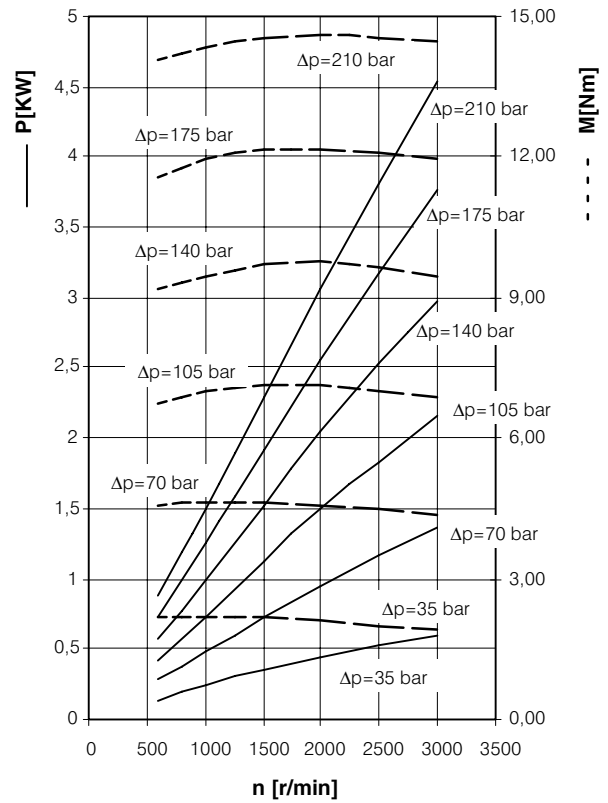

**APM100/6.5**

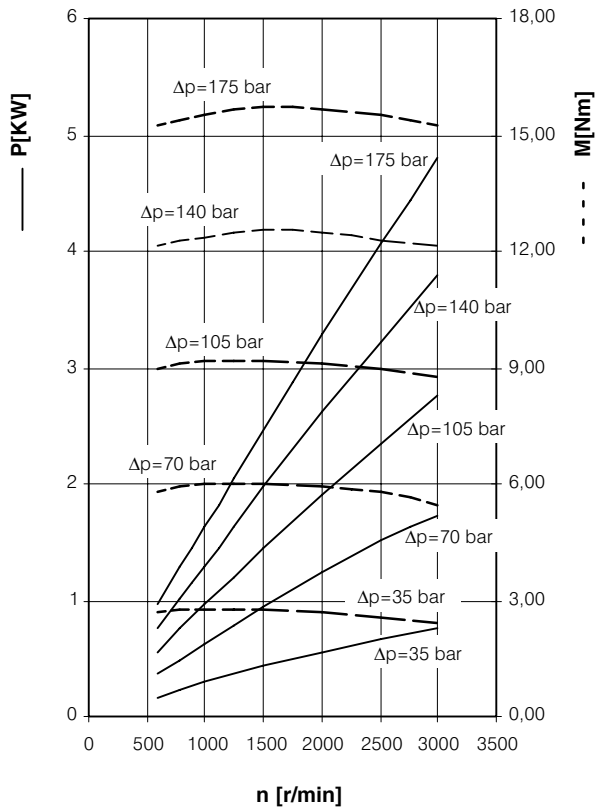

**APM100/8**

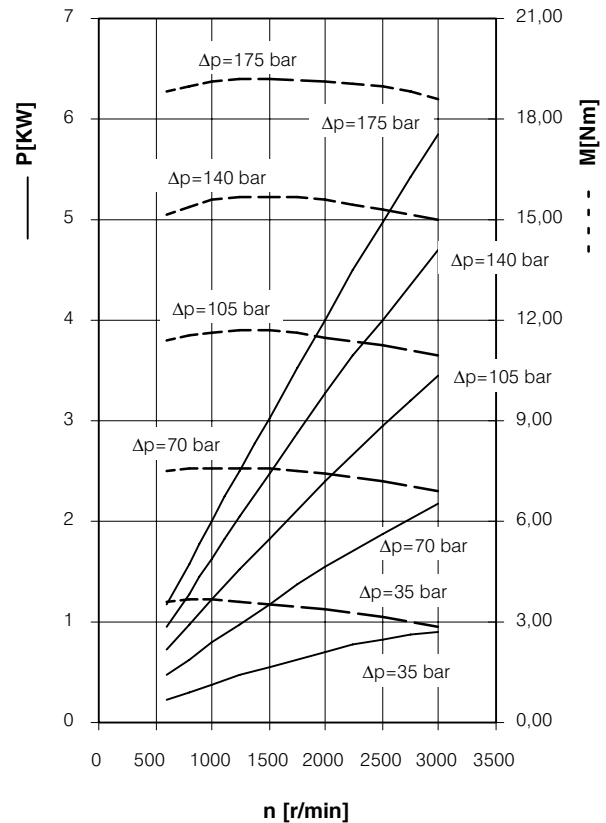

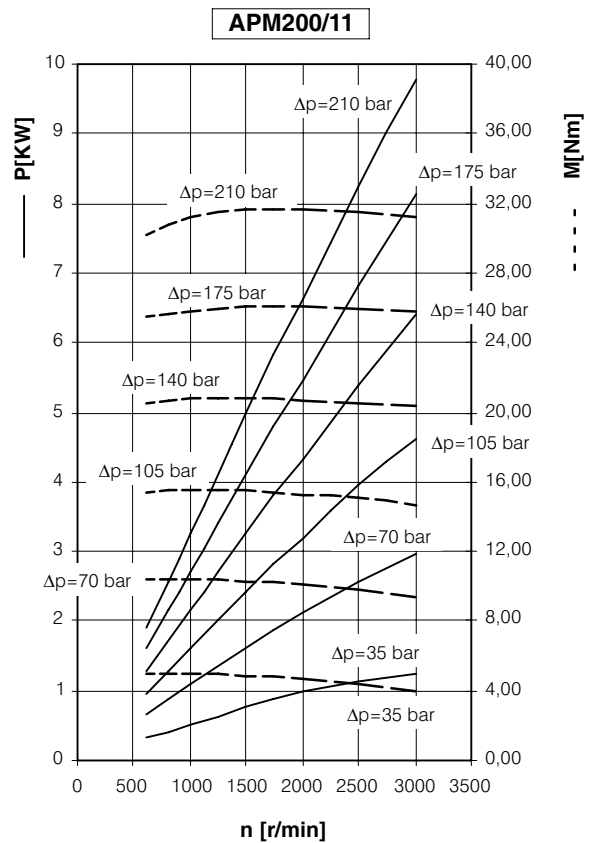
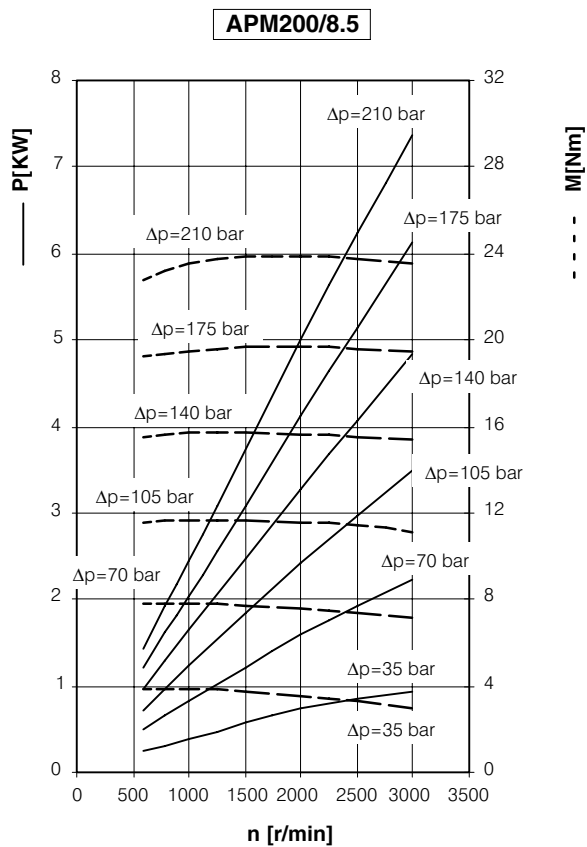
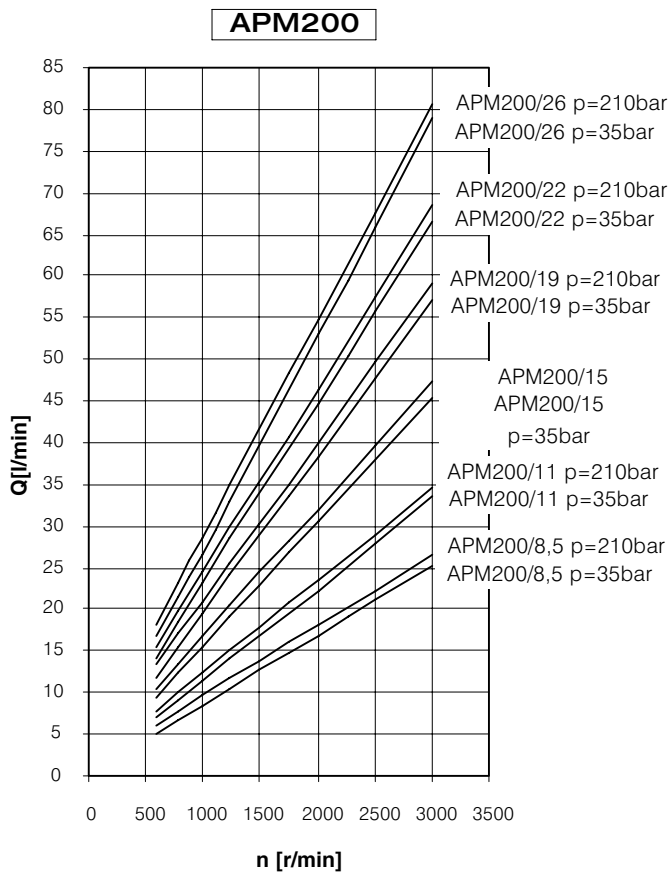

**APM200/15**

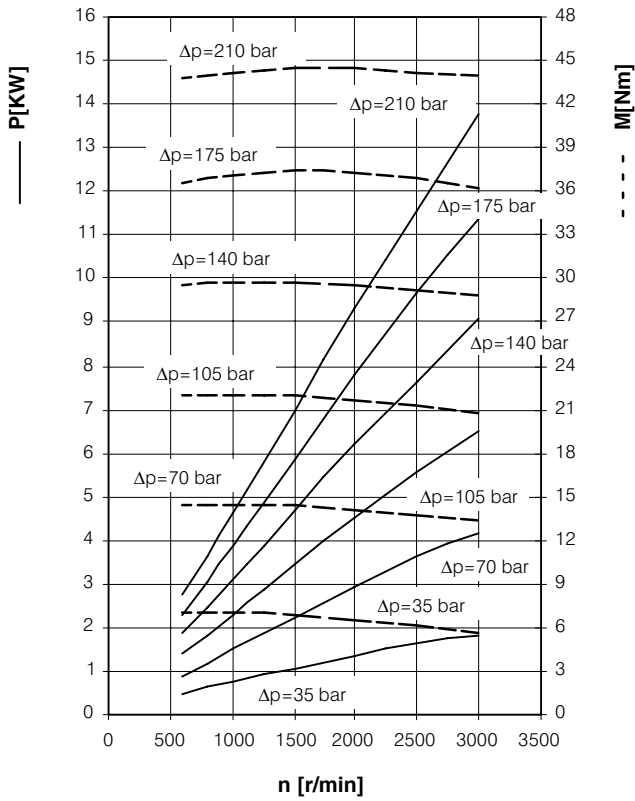

**APM200/19**

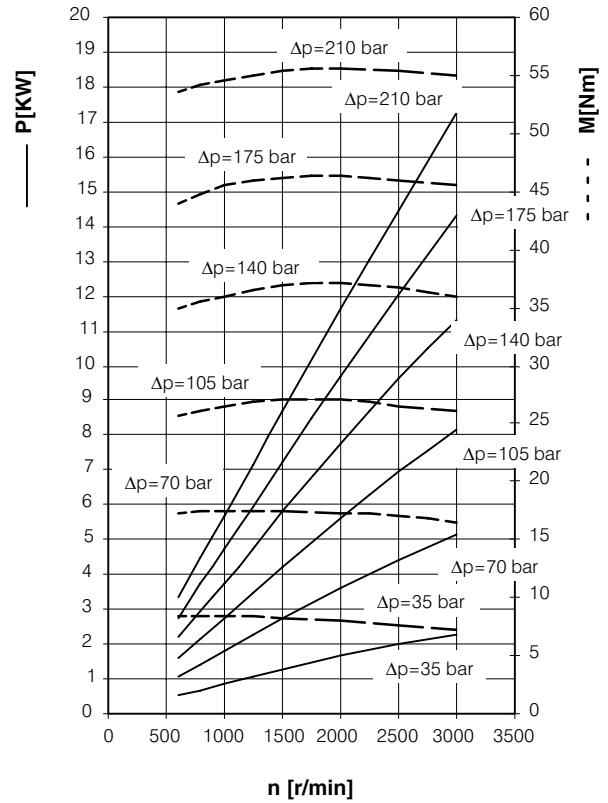

**APM200/22**

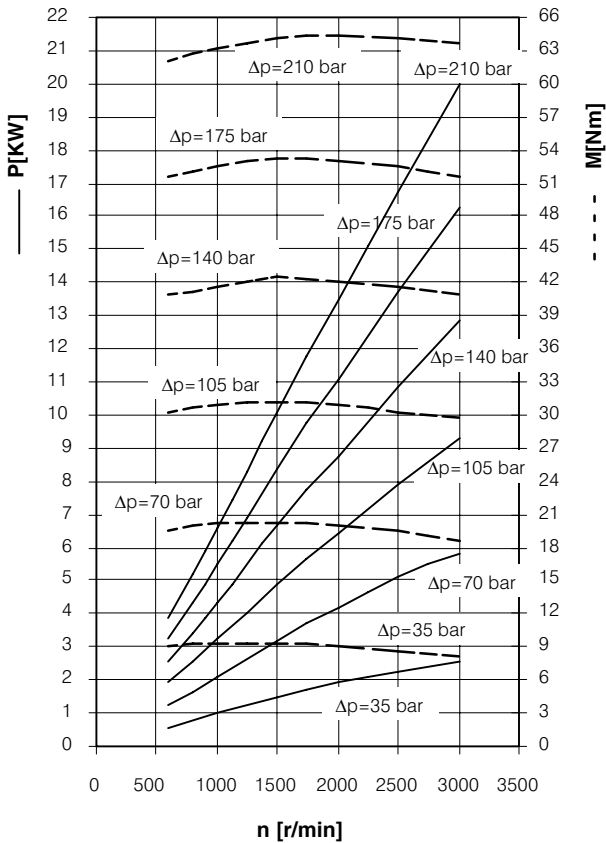

**APM200/26**

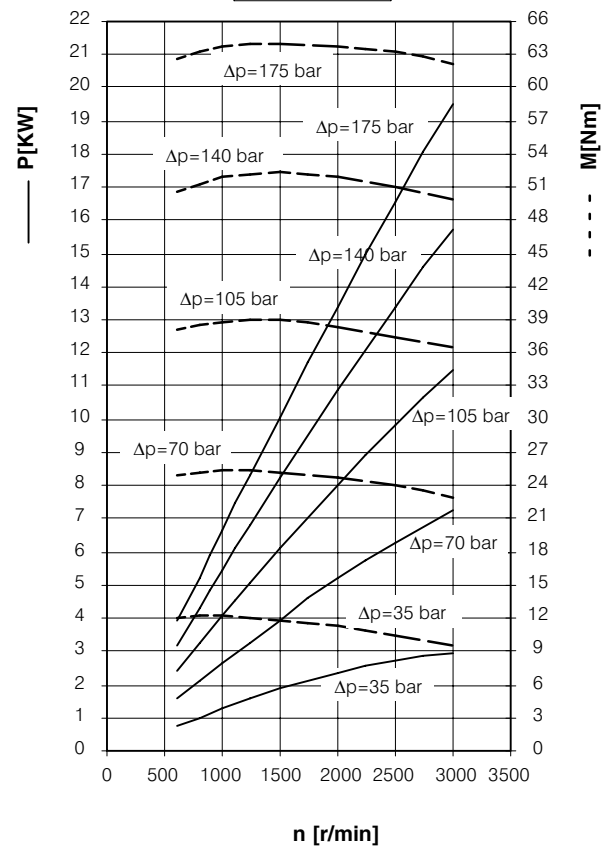

### 3 Gear motors group APM05



APM05 Type	Displacement		Max. pressure				n min. r/min	n max. r/min
	cm <sup>3</sup> /rev	Cu.In. P.R.	P1		P2			
			bar	P.S.I.	bar	P.S.I.		
<b>APM05/0.5</b>	0.5	.030	190	2700	230	3300	800	7000
<b>APM05/0.75</b>	0.75	.045	190	2700	230	3300	800	7000
<b>APM05/0.9</b>	0.9	.055	190	2700	230	3300	800	7000
<b>APM05/1.2</b>	1.2	.073	170	2400	200	2900	700	6000
<b>APM05/1.6</b>	1.6	.097	170	2400	200	2900	700	6000

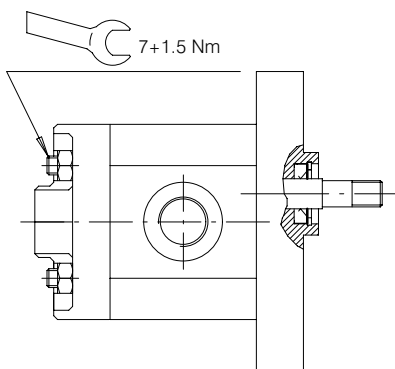

#### Max torque allowed by the shaft end configuration

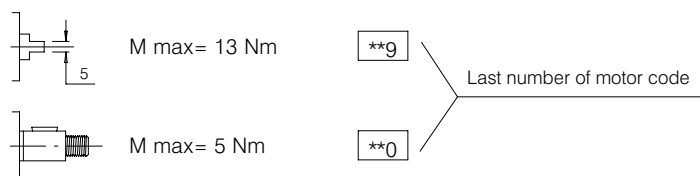

#### Notes:

- For codes and dimensions regarding accessories, see section 6.
- For the types of motors without ordering code, contact our Sales Department.
- For reversible motors inlet and outlet ports have same sizes as per inlet unidirectional rotation

Group **APM05** Code **810**

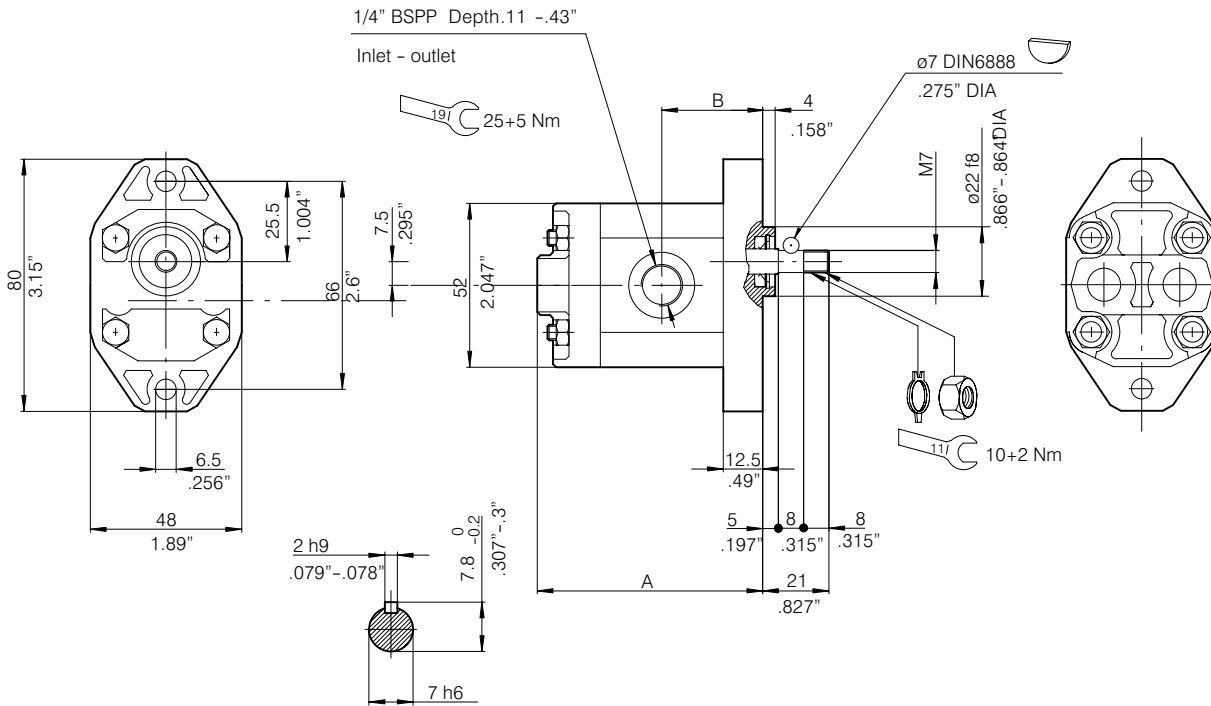

Type	Displacement cm <sup>3</sup> /rev	Dimensions			
		A		B	
		mm	inch.	mm	inch.
<b>APM05/0.5</b>	0.5	67	2.64	30.5	1.2
<b>APM05/0.75</b>	0.75	69	2.72	31.5	1.24
<b>APM05/0.9</b>	0.9	70.5	2.77	32	1.26
<b>APM05/1.2</b>	1.2	73	2.87	33.5	1.32

Unidirectional gear motor

Type	Order Code	Clockwise rotation: D	Type	Order Code	C.clockwise rotation: S
APM05/0.5 D			APM05/0.5 S		
APM05/0.75 D	<b>200.1004.6150.1</b>		APM05/0.75 S		
APM05/0.9 D	<b>200.1005.6150.3</b>		APM05/0.9 S		
APM05/1.2 D	<b>200.1006.6150.1</b>		APM05/1.2 S	<b>200.1006.6160.5</b>	

Group **APM05** Code **819**

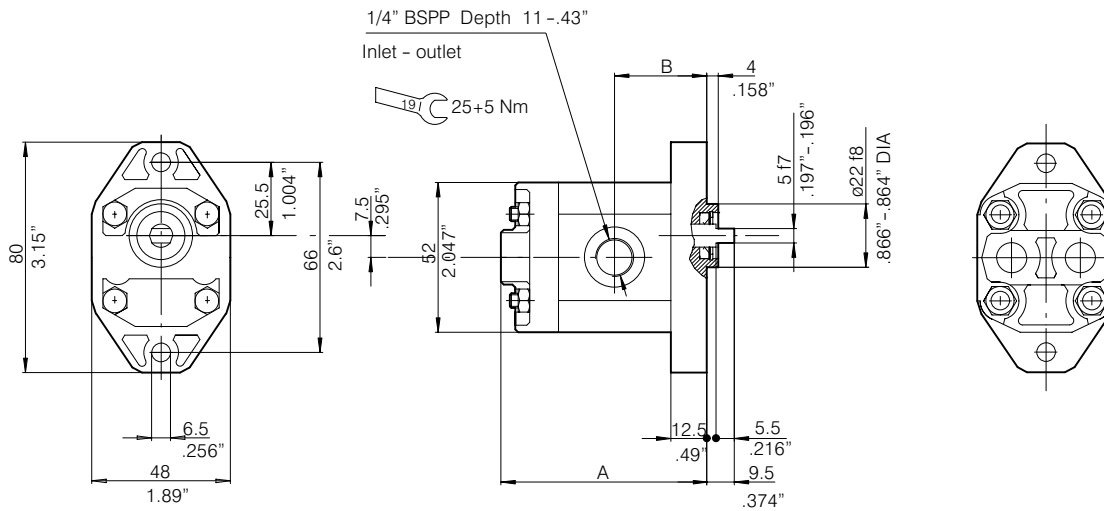

Type	Displacement cm <sup>3</sup> /rev	Dimensions			
		A		B	
		mm	inch.	mm	inch.
<b>APM05/0.5</b>	0.5	67	2.64	30.5	1.2
<b>APM05/0.75</b>	0.75	69	2.72	31.5	1.24
<b>APM05/0.9</b>	0.9	70.5	2.77	32.3	1.26
<b>APM05/1.2</b>	1.2	73	2.87	33.5	1.32
<b>APM05/1.6</b>	1.6	77	3.03	35.5	1.40
<b>APM05/2.3</b>	2.3	83	3.27	39.5	1.55

Unidirectional gear motor

Type	Order Code	Clockwise rotation: D	Type	Order Code	C.clockwise rotation: S
APM05/0.5 D			APM05/0.5 S		
APM05/0.75 D			APM05/0.75 S		
APM05/0.9 D			APM05/0.9 S		
APM05/1.2 D			APM05/1.2 S		
APM05/1.6 D	<b>200100864201</b>		APM05/1.6 S	<b>200100864601</b>	
APM05/2.3 D			APM05/2.3 S		

Group **APM05** Code **310**

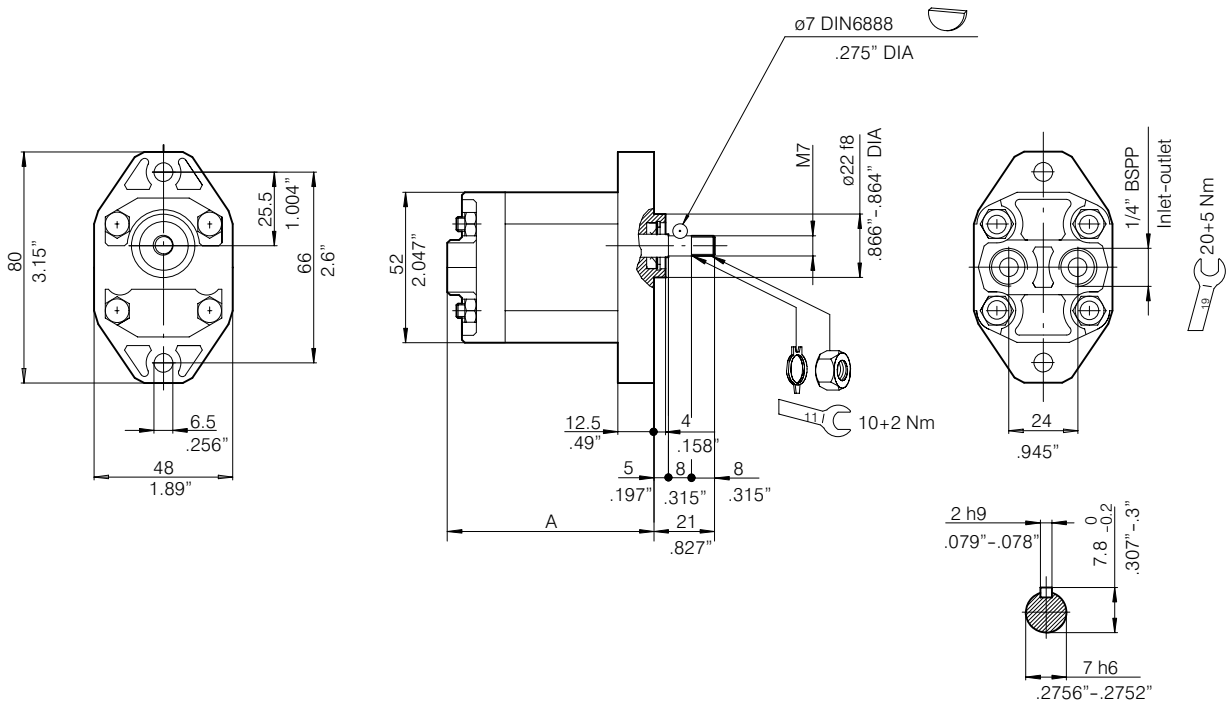

Type	Displacement cm <sup>3</sup> /rev	Dimensions	
		A	
		mm	inch.
<b>APM05/0.5</b>	0.5	67	2.64
<b>APM05/0.75</b>	0.75	69	2.72
<b>APM05/0.9</b>	0.9	70.5	2.77
<b>APM05/1.2</b>	1.2	73	2.87

Unidirectional gear motor

Type	Order Code	Clockwise rotation: D	Type	Order Code	C.clockwise rotation: S
APM05/0.5 D			APM05/0.5 S		
APM05/0.75 D	<b>200100460201</b>				
APM05/0.9 D	<b>200100560202</b>				
APM05/1.2 D					

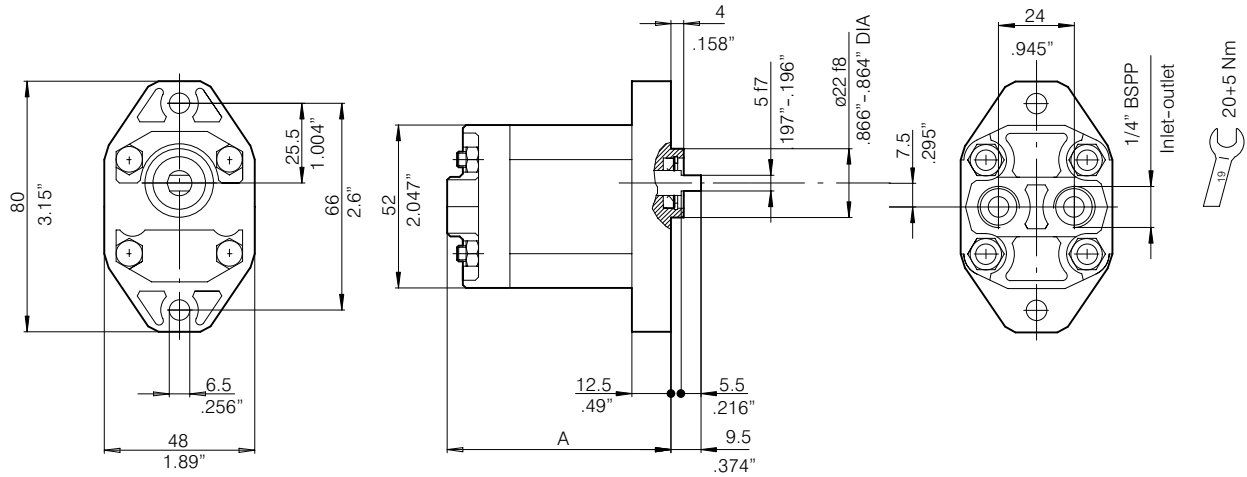

Type	Displacement cm <sup>3</sup> /rev	Dimensions	
		A	
		mm	inch.
<b>APM05/0.5</b>	0.5	67	2.64
<b>APM05/0.75</b>	0.75	69	2.72
<b>APM05/0.9</b>	0.9	70.5	2.77
<b>APM05/1.2</b>	1.2	73	2.87
<b>APM05/1.6</b>	1.6	77	3.03
<b>APM05/1.6</b>	1.6	77	3.03
<b>APM05/2.3</b>	2.3	83	3.27

Unidirectional gear motor

Type	Order Code	Clockwise rotation: D	Type	Order Code	C.clockwise rotation: S
APM05/0.5 D			APM05/0.5 S		
APM05/0.75 D			APM05/0.75 S		
APM05/0.9 D			APM05/0.9 S		
APM05/1.2 D			APM05/1.2 S		
APM05/1.6 D			APM05/1.6 S		
APM05/2.3 D			APM05/2.3 S		

Group **APM05** Code **830**

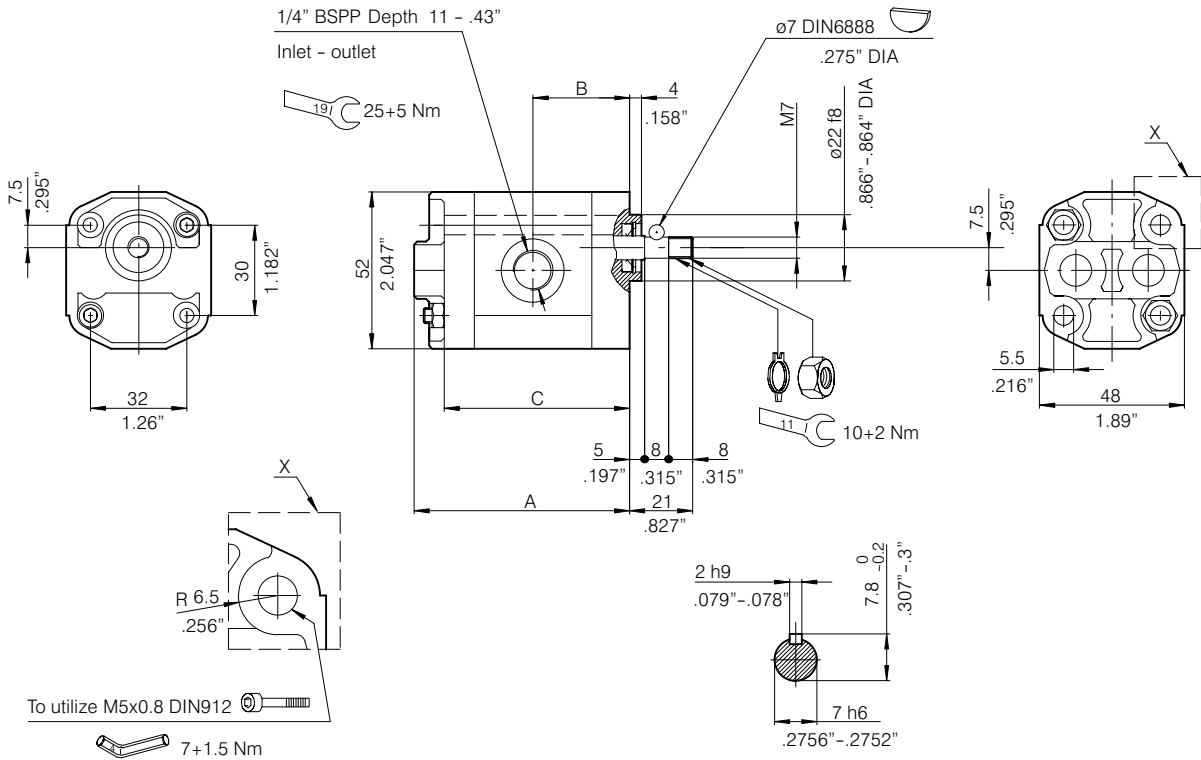

Type	Displacement cm <sup>3</sup> /rev	Dimensions					
		A		B		C	
		mm	inch.	mm	inch.	mm	inch.
<b>APM05/0.5</b>	0.5	67	2.64	30.5	1.2	56	2.20
<b>APM05/0.75</b>	0.75	69	2.72	31.5	1.24	58	2.28
<b>APM05/0.9</b>	0.9	70.5	2.77	32	1.26	59.5	2.34
<b>APM05/1.2</b>	1.2	73	2.87	33.5	1.32	62	2.44

Unidirectional gear motor

Type	Order Code	Clockwise rotation: D	Type	Order Code	C.clockwise rotation: S
APM05/0.5 D			APM05/0.5 S		
APM05/0.75 D			APM05/0.75 S		
APM05/0.9 D			APM05/0.9 S		
APM05/1.2 D			APM05/1.2 S		

Group **APM05** Code **839**

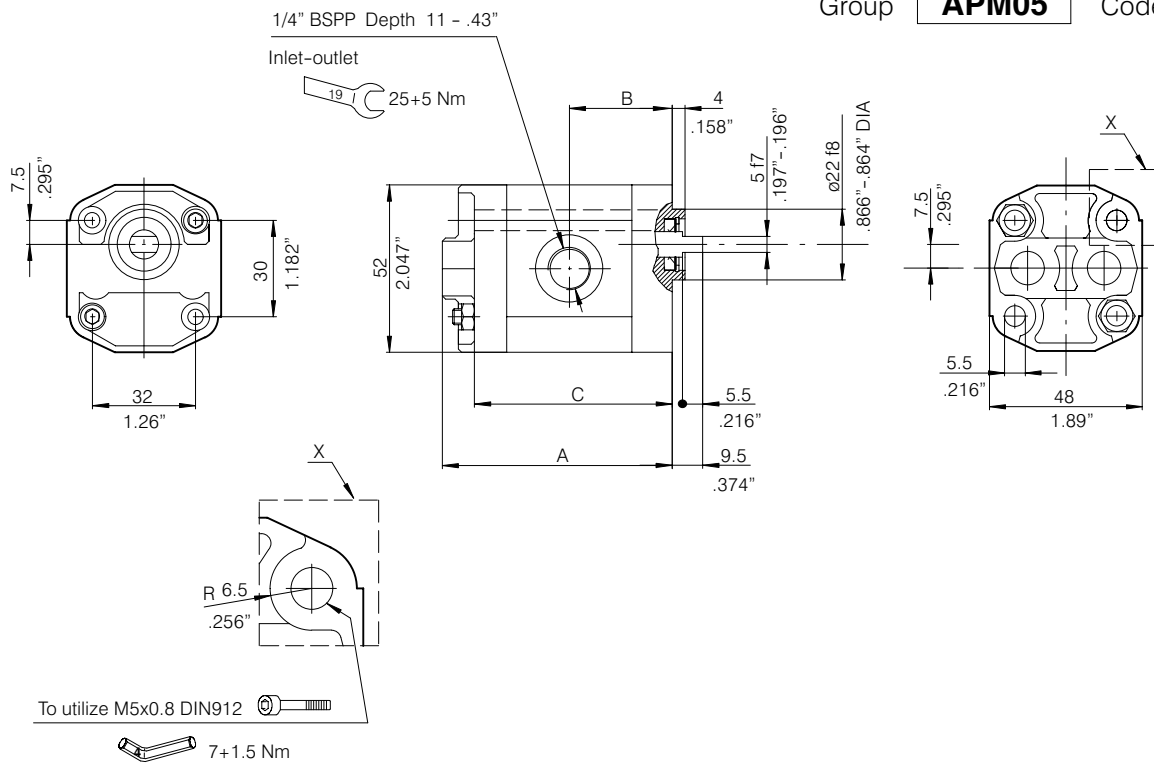

Type	Displacement cm <sup>3</sup> /rev	Dimensions					
		A		B		C	
		mm.	inch.	mm	inch.	mm	inch.
<b>APM05/0.5</b>	0.5	67	2.64	30.5	1.2	56	2.20
<b>APM05/0.75</b>	0.75	69	2.72	31.5	1.24	58	2.28
<b>APM05/0.9</b>	0.9	70.5	2.77	32	1.26	59.5	2.34
<b>APM05/1.2</b>	1.2	73	2.87	33.5	1.32	62	2.44
<b>APM05/1.6</b>	1.6	77	3.03	35.5	1.40	66	2.60
<b>APM05/2.3</b>	2.3	83	3.27	39.5	1.55		

Unidirectional gear motor

Type	Order Code	Clockwise rotation: D	Type	Order Code	C.clockwise rotation: S
APM05/0.5 D			APM05/0.5 S		
APM05/0.75 D			APM05/0.75 S		
APM05/0.9 D			APM05/0.9 S		
APM05/1.2 D			APM05/1.2 S		
APM05/1.6 D			APM05/1.6 S	<b>200100834602</b>	
APM05/2.3 D			APM05/2.3 S		

Group **APM05** Code **330**

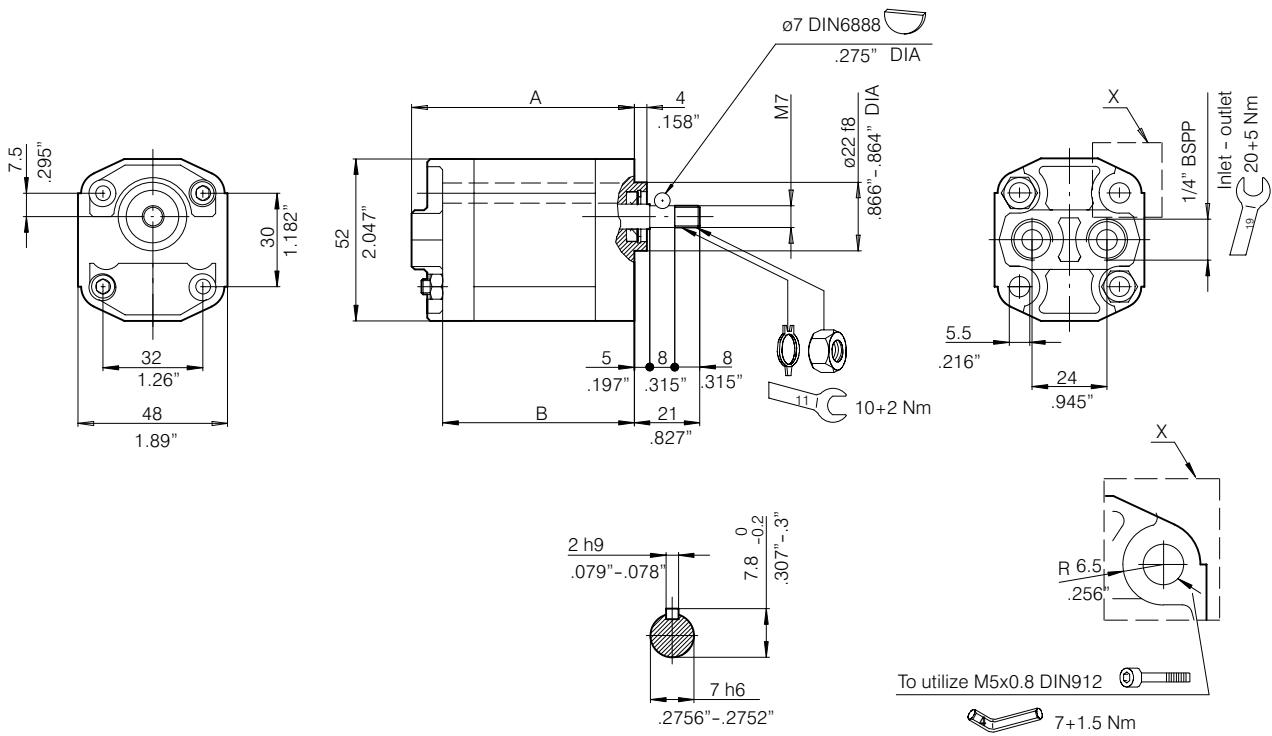

Type	Displacement cm <sup>3</sup> /rev	Dimensions			
		A		B	
		mm	inch.	mm	inch.
<b>APM05/0.5</b>	0.5	67	2.64	56	2.20
<b>APM05/0.75</b>	0.75	69	2.72	58	2.28
<b>APM05/0.9</b>	0.9	70.5	2.77	59.5	2.34
<b>APM05/1.2</b>	1.2	73	2.87	62	2.44

Unidirectional gear motor

Type	Order Code	Clockwise rotation: D	Type	Order Code	C.clockwise rotation: S
APM05/0.5 D			APM05/0.5 S		
APM05/0.75 D			APM05/0.75 S		
APM05/0.9 D			APM05/0.9 S		
APM05/1.2 D			APM05/1.2 S		

Group **APM05** Code **339**

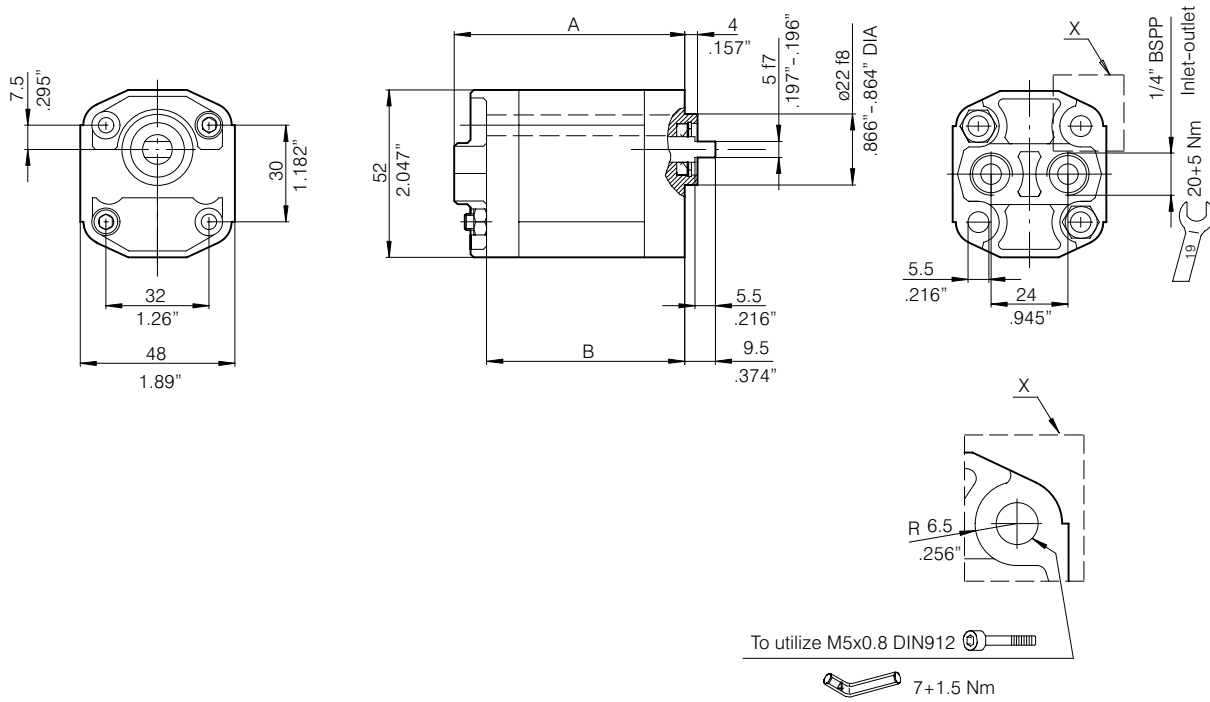

Type	Displacement cm <sup>3</sup> /rev	Dimensions			
		A		B	
		mm	inch.	mm	inch.
<b>APM05/0.5</b>	0.5	67	2.64	56	2.20
<b>APM05/0.75</b>	0.75	69	2.72	58	2.28
<b>APM05/0.9</b>	0.9	70.5	2.77	59.5	2.34
<b>APM05/1.2</b>	1.2	73	2.87	62	2.44
<b>APM05/1.6</b>	1.6	77	3.03	66	2.60
<b>APM05/2.3</b>	2.3	83	3.27		

Unidirectional gear motor

Type	Order Code	Clockwise rotation: D	Type	Order Code	C.clockwise rotation: S
APM05/0.5 D			APM05/0.5 S		
APM05/0.75 D			APM05/0.75 S		
APM05/0.9 D			APM05/0.9 S		
APM05/1.2 D			APM05/1.2 S		
APM05/1.6 D			APM05/1.6 S		
APM05/2.3 D			APM05/2.3 S		

## 4 Gear motors group APM100

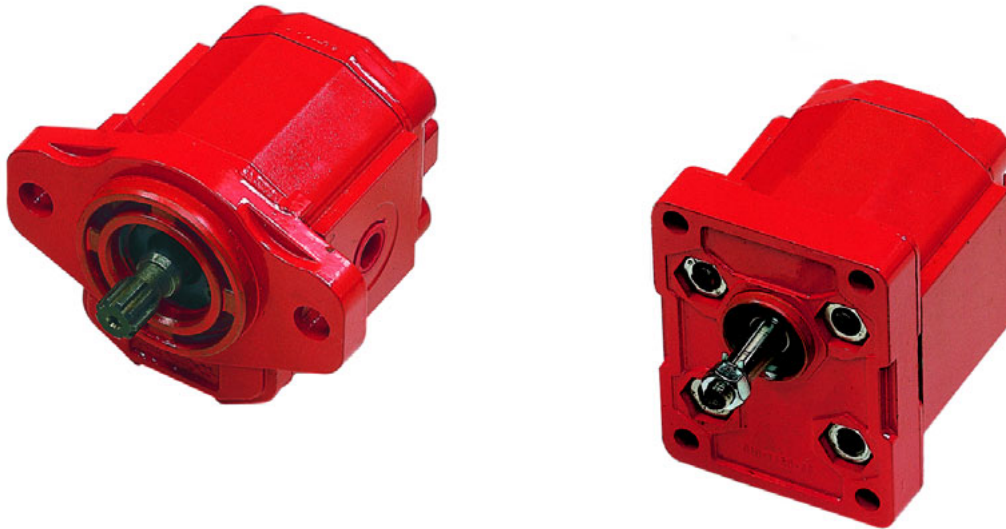

APM100 Type	Displacement		Max. pressure				n min. r/min	n max. r/min
	cm <sup>3</sup> /rev	Cu.In. P.R.	P1		P2			
			bar	P.S.I.	bar	P.S.I.		
<b>APM100/2.5</b>	2.5	.152	210	3000	280	4000	650	5000
<b>APM100/3.5</b>	3.5	.213	210	3000	250	3600	650	4000
<b>APM100/4.3</b>	4.3	.262	210	3000	250	3600	550	4000
<b>APM100/5</b>	5	.305	210	3000	250	3600	500	3500
<b>APM100/6.5</b>	6.5	.396	190	2700	240	3400	500	3000
<b>APM100/8</b>	7.8	.476	180	2600	230	3300	500	3000
<b>APM100/10</b>	10	.610	150	2150	200	2900	500	2500

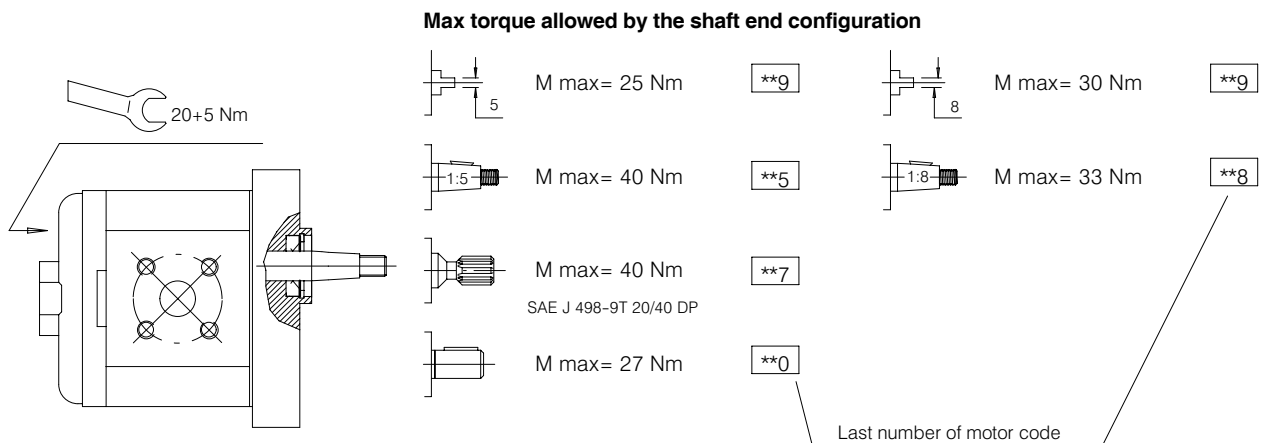

**Notes:**

- For codes and dimensions regarding accessories, see section 6.
- For the types of motors without ordering code, contact our Sales Department.
- For reversible motors inlet and outlet ports have same sizes as per inlet unidirectional rotation

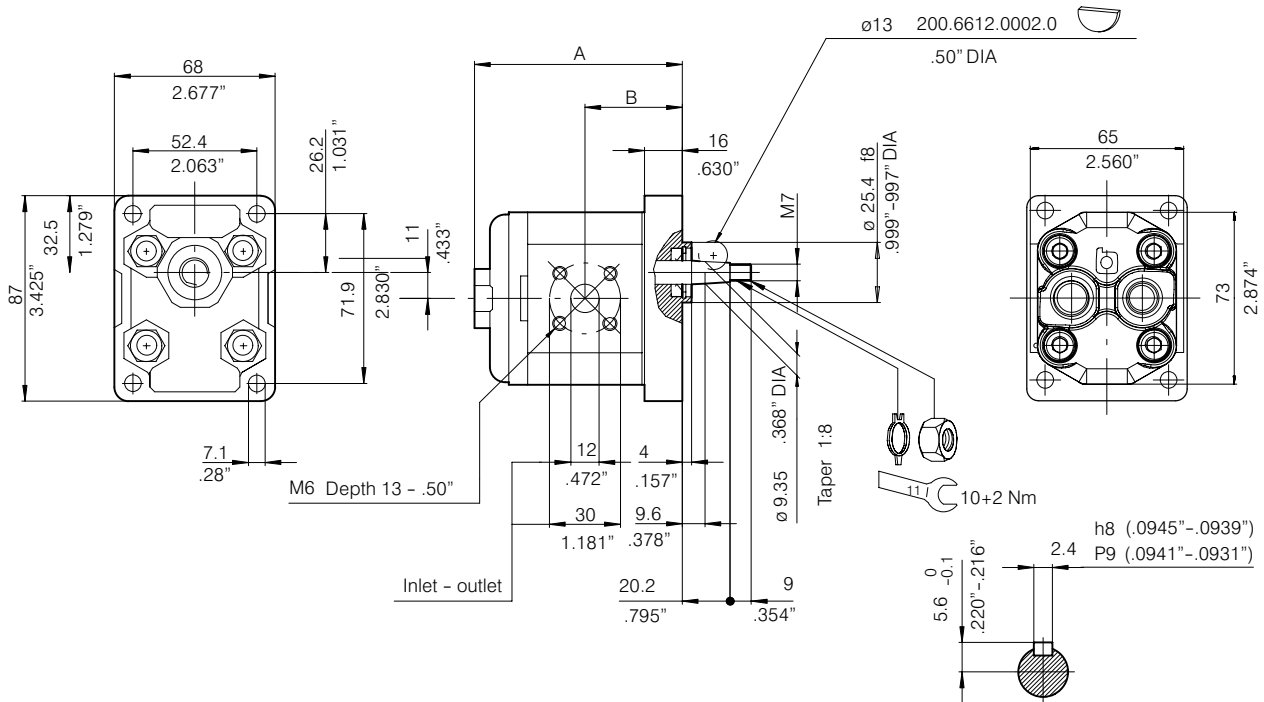

Type	Displacement cm <sup>3</sup> /rev	Dimensions			
		A		B	
		mm	inch.	mm	inch.
<b>APM100/2.5</b>	2.5	88	3.46	41	1.61
<b>APM100/3.5</b>	3.5	92	3.62	43.5	1.71
<b>APM100/4.3</b>	4.3	96	3.78	45	1.77
<b>APM100/5</b>	5	98.5	3.88	46.5	1.83
<b>APM100/6.5</b>	6.5	103.5	4.07	49	1.93
<b>APM100/8</b>	7.8	109	4.29	52	2.05

**Unidirectional gear motor**

Type	Order Code	Clockwise rotation: D	Type	Order Code	C.clockwise rotation: S
APM100/2.5 D	<b>200101313209</b>		APM100/2.5 S	<b>200101313601</b>	
APM100/3.5 D	<b>200101413501</b>				
APM100/4.3 D	<b>200101513501</b>				
APM100/5 D	<b>200101613501</b>				
APM100/6.5 D	<b>200101713501</b>				
APM100/8 D	<b>200101813501</b>				
			APM100/2.5 S	<b>200101413601</b>	
			APM100/3.5 S	<b>200101513601</b>	
			APM100/4.3 S	<b>200101613601</b>	
			APM100/5 S	<b>200101713601</b>	
			APM100/6.5 S	<b>200101813601</b>	
			APM100/8 S		

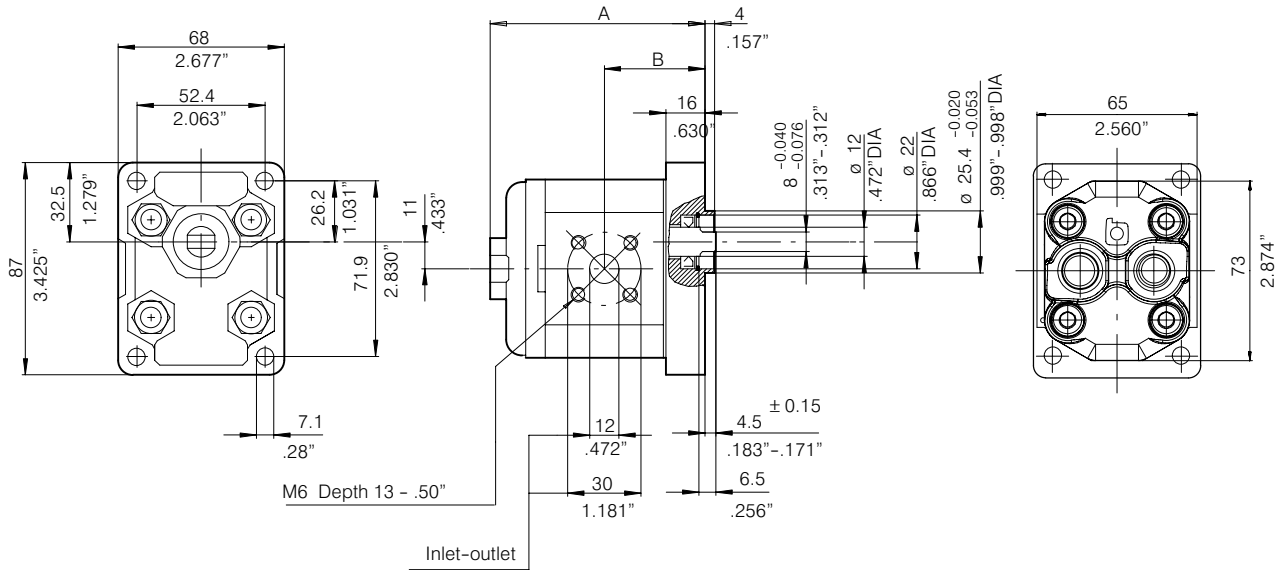

Type	Displacement cm <sup>3</sup> /rev	Dimensions			
		A		B	
		mm	inch.	mm	inch.
<b>APM100/2.5</b>	2.5	88	3.46	41	1.61
<b>APM100/3.5</b>	3.5	92	3.62	43.5	1.71
<b>APM100/4.3</b>	4.3	96	3.78	45	1.77
<b>APM100/5</b>	5	98.5	3.88	46.5	1.83
<b>APM100/6.5</b>	6.5	103.5	4.07	49	1.93
<b>APM100/8</b>	7.8	109	4.29	52	2.05
<b>APM100/10</b>	10	118	4.64	56.5	2.22

Unidirectional gear motor

Type	Order Code	Clockwise rotation: D	Type	Order Code	C.clockwise rotation: S
APM100/2.5 D			APM100/2.5 S		
APM100/3.5 D			APM100/3.5 S		
APM100/4.3 D	<b>200101514501</b>		APM100/4.3 S	<b>200101514601</b>	
APM100/5 D			APM100/5 S		
APM100/6.5 D			APM100/6.5 S		
APM100/8 D			APM100/8 S		
APM100/10 D			APM100/10 S		

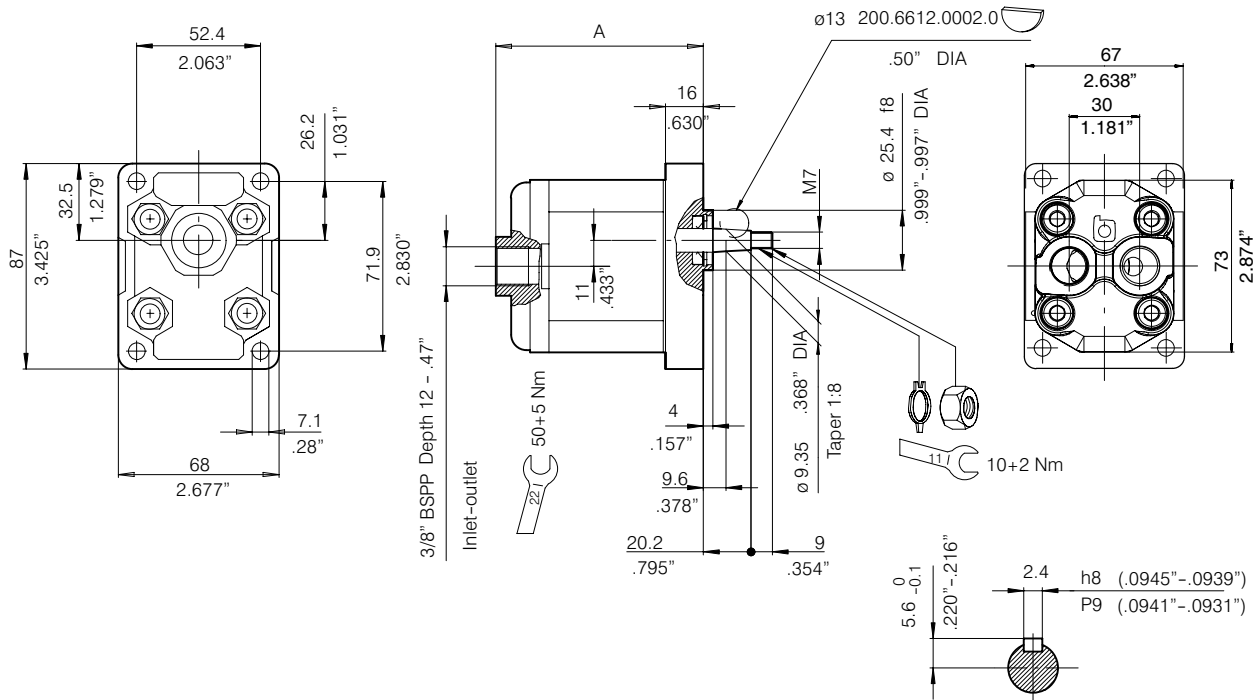

Type	Displacement cm <sup>3</sup> /rev	Dimensions	
		A	
		mm	inch.
<b>APM100/2.5</b>	2.5	88	3.46
<b>APM100/3.5</b>	3.5	92	3.62
<b>APM100/4.3</b>	4.3	96	3.78
<b>APM100/5</b>	5	98.5	3.88
<b>APM100/6.5</b>	6.5	103.5	4.07
<b>APM100/8</b>	7.8	109	4.29

Unidirectional gear motor

Type	Order Code	Clockwise rotation: D	Type	Order Code	C.clockwise rotation: S
APM100/2.5 D			APM100/2.5 S		
APM100/3.5 D			APM100/3.5 S		
APM100/4.3 D	<b>200101513502</b>		APM100/4.3 S	<b>200101513602</b>	
APM100/5 D			APM100/5 S		
APM100/6.5 D			APM100/6.5 S		
APM100/8 D			APM100/8 S		

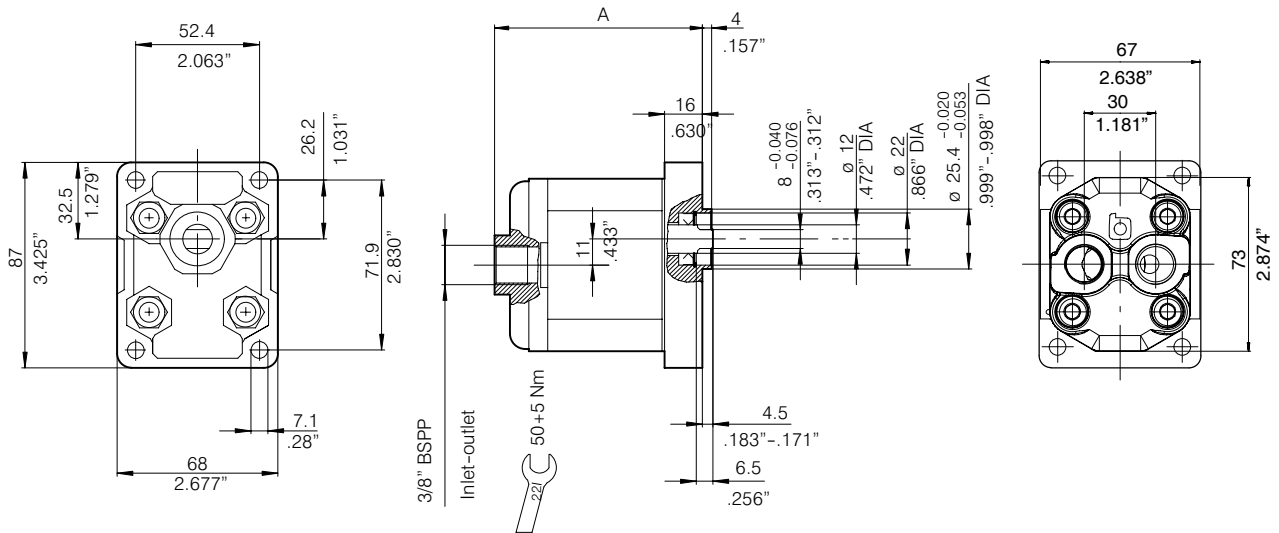

Type	Displacement cm <sup>3</sup> /rev	Dimensions	
		A	
		mm	inch.
<b>APM100/2.5</b>	2.5	88	3.46
<b>APM100/3.5</b>	3.5	92	3.62
<b>APM100/4.3</b>	4.3	96	3.78
<b>APM100/5</b>	5	98.5	3.88
<b>APM100/6.5</b>	6.5	103.5	4.07
<b>APM100/8</b>	7.8	109	4.29
<b>APM100/10</b>	10	118	4.64

Unidirectional gear motor

Type	Order Code	Clockwise rotation: D	Type	Order Code	C.clockwise rotation: S
APM100/2.5 D			APM100/2.5 S	<b>200101314601</b>	
APM100/3.5 D			APM100/3.5 S		
APM100/4.3 D			APM100/4.3 S		
APM100/5 D			APM100/5 S		
APM100/6.5 D			APM100/6.5 S		
APM100/8 D			APM100/8 S		
APM100/10 D			APM100/10 S		

Group **APM100** Code **818**

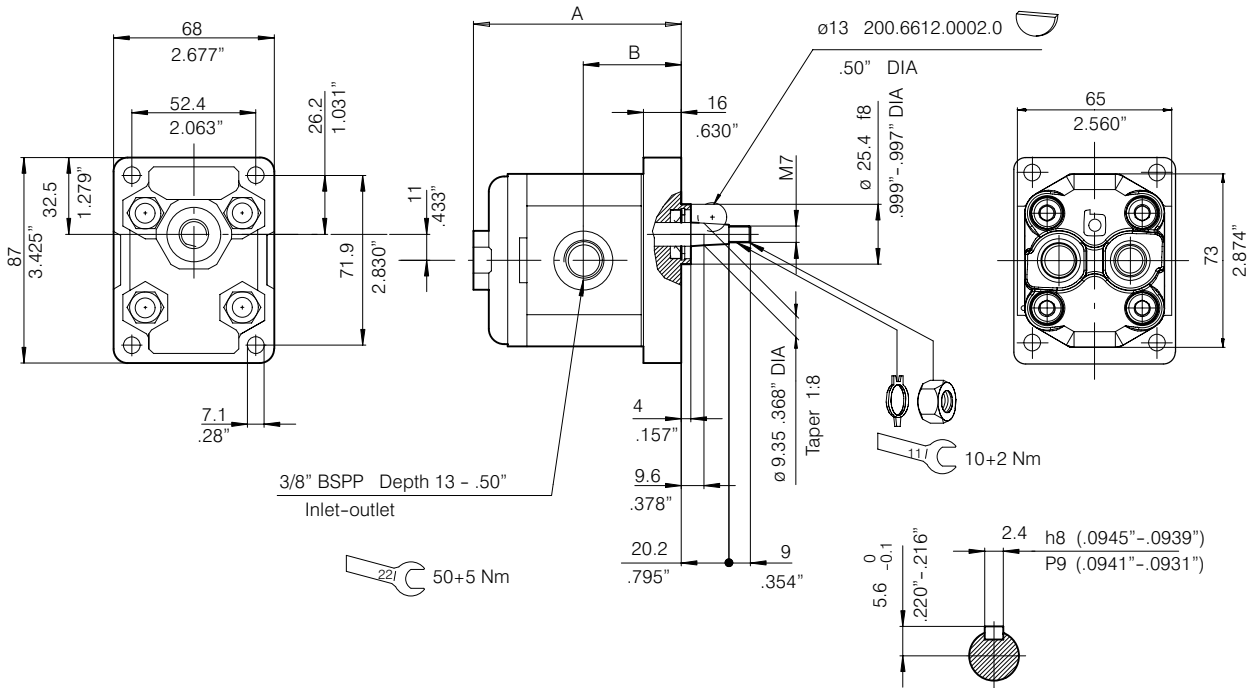

Type	Displacement cm <sup>3</sup> /rev	Dimensions			
		A		B	
		mm	inch.	mm	inch.
<b>APM100/2.5</b>	2.5	88	3.46	41	1.61
<b>APM100/3.5</b>	3.5	92	3.62	43.5	1.71
<b>APM100/4.3</b>	4.3	96	3.78	45	1.77
<b>APM100/5</b>	5	98.5	3.88	46.5	1.83
<b>APM100/6.5</b>	6.5	103.5	4.07	49	1.93
<b>APM100/8</b>	7.8	109	4.29	52	2.05

Unidirectional gear motor

Type	Order Code	Clockwise rotation: D	Type	Order Code	C.clockwise rotation: S
APM100/2.5 D			APM100/2.5 S	<b>200101313602</b>	
APM100/3.5 D			APM100/3.5 S		
APM100/4.3 D	<b>200101513503</b>		APM100/4.3 S		
APM100/5 D			APM100/5 S		
APM100/6.5 D			APM100/6.5 S		
APM100/8 D			APM100/8 S		

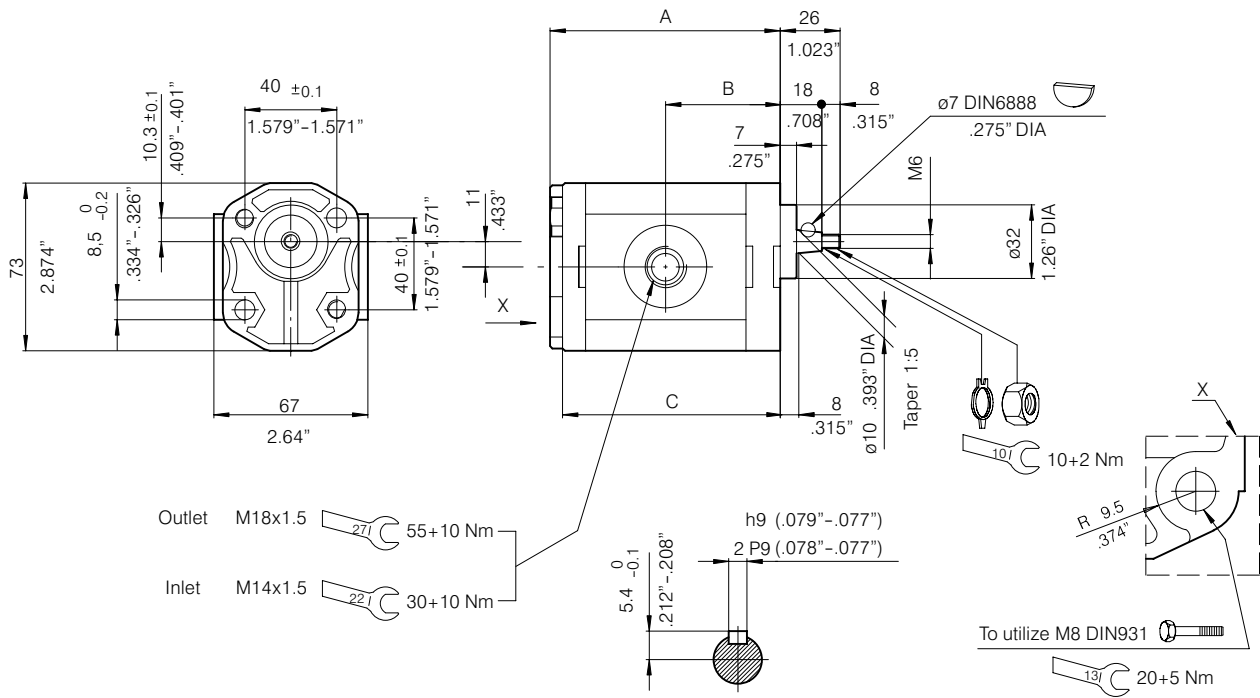

Type	Displacement cm <sup>3</sup> /rev	Dimensions					
		A		B		C	
		mm	inch.	mm	inch.	mm	inch.
<b>APM100/2.5</b>	2.5	79	2.99	39	1.53	75.5	2.97
<b>APM100/3.5</b>	3.5	83	3.27	41	1.61	80	3.15
<b>APM100/4.3</b>	4.3	87	3.42	43	1.69	83.5	3.29
<b>APM100/5</b>	5	89.5	3.52	44.5	1.75	86	3.38
<b>APM100/6.5</b>	6.5	94.5	3.72	47	1.85	91	3.58
<b>APM100/8</b>	7.8	100	3.98	50	1.97	97	3.81

Unidirectional gear motor

Type	Order Code	Clockwise rotation: D	Type	Order Code	C.clockwise rotation: S
APM100/2.5 D			APM100/2.5 S		
APM100/3.5 D			APM100/3.5 S	<b>200101442601</b>	
APM100/4.3 D			APM100/4.3 S	<b>200101542604</b>	
APM100/5 D			APM100/5 S	<b>200101642603</b>	
APM100/6.5 D			APM100/6.5 S		
APM100/8 D			APM100/8 S		

Group **APM100** Code **880**

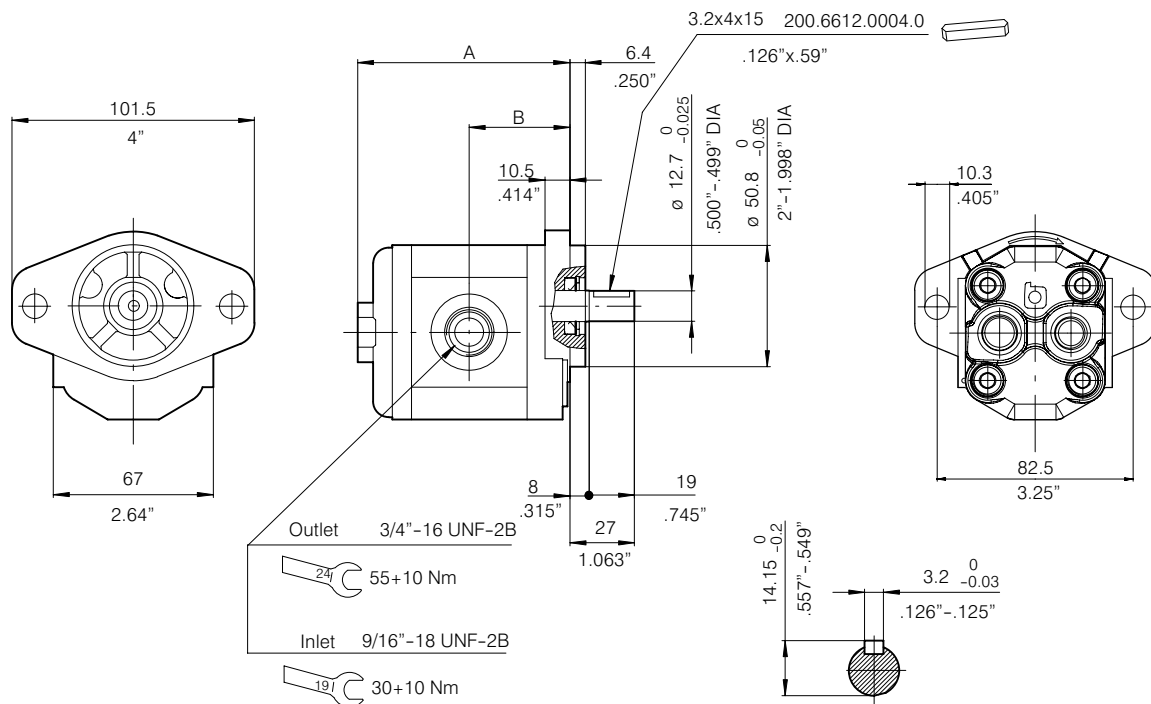

Type	Displacement cm <sup>3</sup> /rev	Dimensions			
		A		B	
		mm	inch.	mm	inch.
<b>APM100/2.5</b>	2.5	89	3.50	42	1.65
<b>APM100/3.5</b>	3.5	93	3.66	44.5	1.75
<b>APM100/4.3</b>	4.3	97	3.82	46	1.81
<b>APM100/5</b>	5	99.5	3.92	47.5	1.87
<b>APM100/6.5</b>	6.5	104.5	4.11	50	1.97
<b>APM100/8</b>	8	110	4.33	53	2.09

Unidirectional gear motor

Type	Order Code	Clockwise rotation: D	Type	Order Code	C.clockwise rotation: S
APM100/2.5 D	<b>200101380501</b>		APM100/2.5 S	<b>200101380601</b>	
APM100/3.5 D	<b>200101480501</b>		APM100/3.5 S	<b>200101480601</b>	
APM100/4.3 D	<b>200101580501</b>		APM100/4.3 S	<b>200101580601</b>	
APM100/5 D			APM100/5 S		
APM100/6.5 D			APM100/6.5 S		
APM100/8 D			APM100/8 S		

Group **APM100** Code **887S**

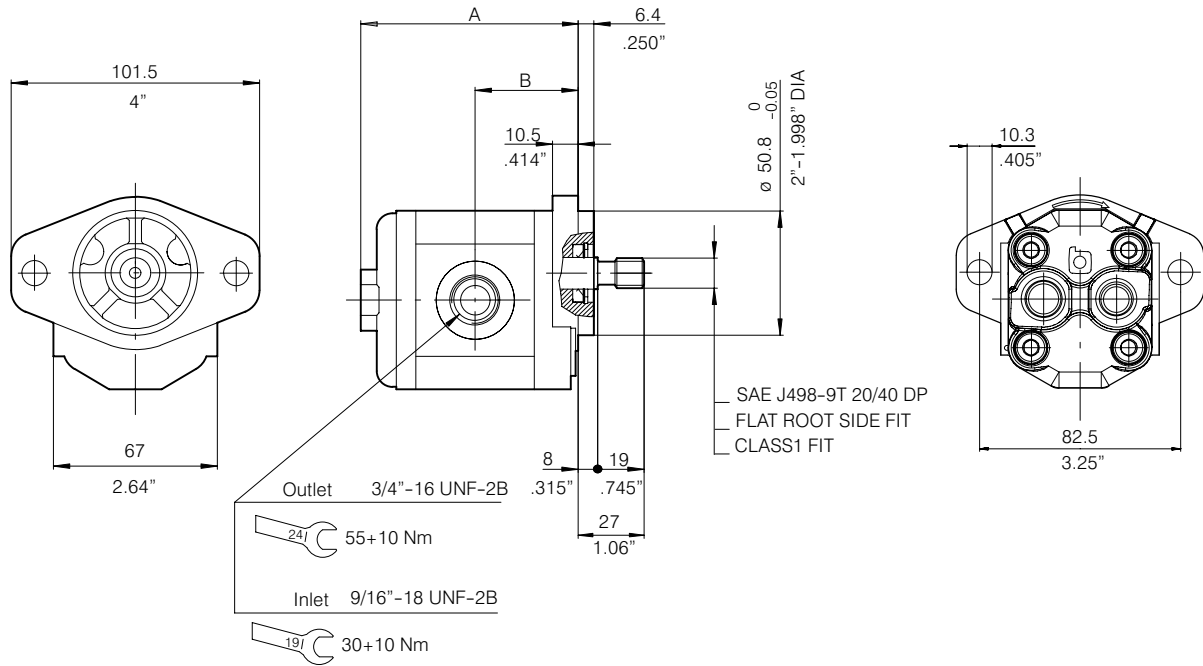

Type	Displacement cm <sup>3</sup> /rev	Dimensions			
		A		B	
		mm	inch.	mm	inch.
<b>APM100/2.5</b>	2.5	89	3.50	42	1.65
<b>APM100/3.5</b>	3.5	93	3.66	44.5	1.75
<b>APM100/4.3</b>	4.3	97	3.82	46	1.81
<b>APM100/5</b>	5	99.5	3.92	47.5	1.87
<b>APM100/6.5</b>	6.5	104.5	4.11	50	1.97
<b>APM100/8</b>	7.8	110	4.33	53	2.09

Unidirectional gear motor

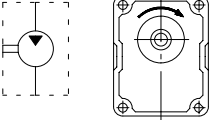
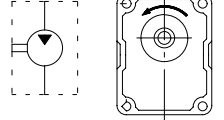
Type	Order Code	Clockwise rotation: D	Type	Order Code	C.clockwise rotation: S
APM100/2.5 D	<b>200101386501</b>		APM100/2.5 S		
APM100/3.5 D			APM100/3.5 S		
APM100/4.3 D			APM100/4.3 S		
APM100/5 D			APM100/5 S		
APM100/6.5 D			APM100/6.5 S		
APM100/8 D			APM100/8 S		



Group **APM100** Code **387S**

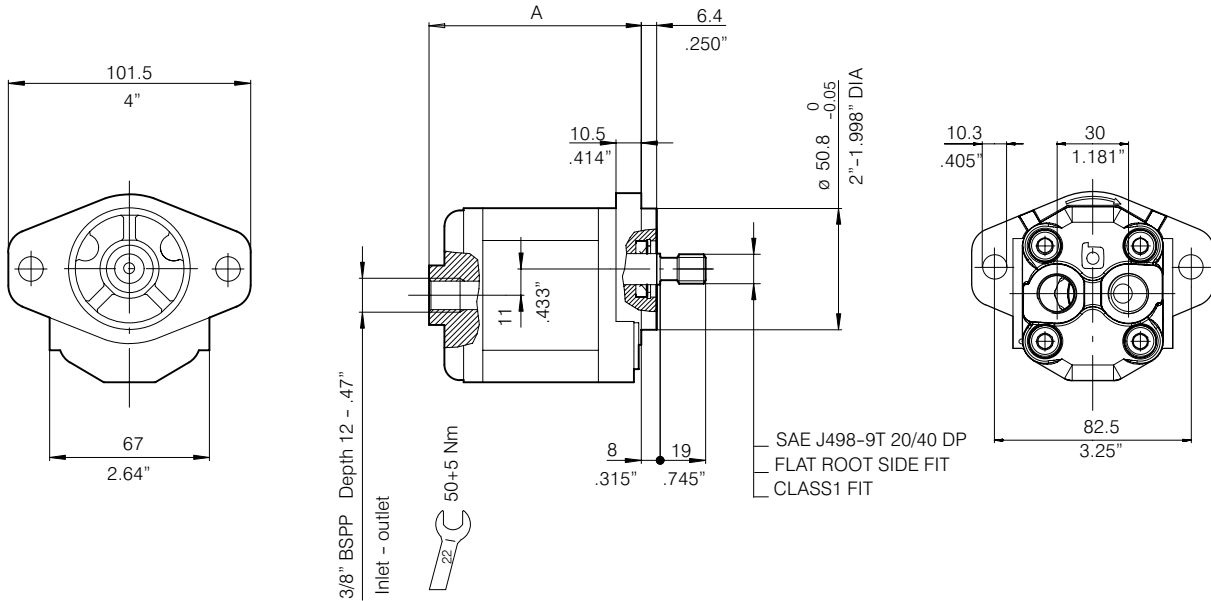

Type	Displacement cm <sup>3</sup> /rev	Dimensions	
		A	
		mm	inch.
<b>APM100/2.5 D</b>	2.5	89	3.50
<b>APM100/3.5 D</b>	3.5	93	3.66
<b>APM100/4.3 D</b>	4.3	97	3.82
<b>APM100/5 D</b>	5	99.5	3.92
<b>APM100/6.5 D</b>	6.5	104.5	4.11
<b>APM100/8 D</b>	8	110	4.33

Unidirectional gear motor

Type	Order Code	Clockwise rotation: D	Type	Order Code	C.clockwise rotation: S
APM100/2.5 D			APM100/2.5 S		
APM100/3.5 D			APM100/3.5 S		
APM100/4.3 D			APM100/4.3 S		
APM100/5 D			APM100/5 S		
APM100/6.5 D			APM100/6.5 S		
APM100/8 D			APM100/8 S		

Group **APM100** Code **880 NPTF**

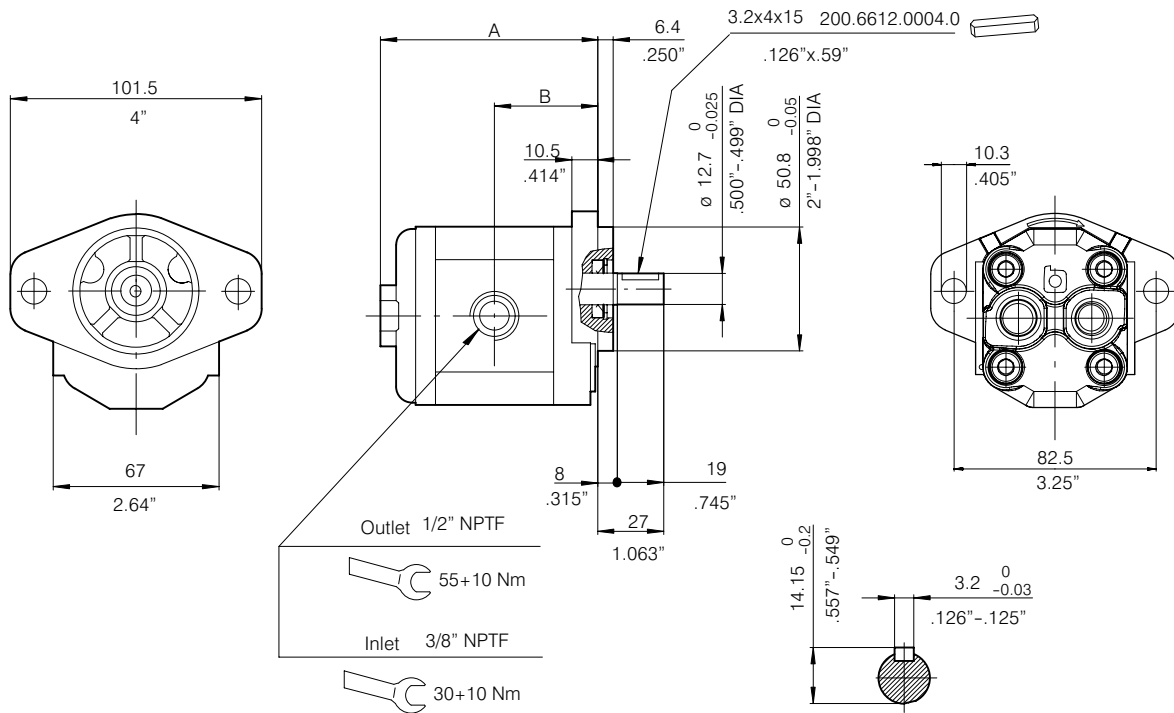

Type	Displacement cm <sup>3</sup> /rev	Dimensions			
		A		B	
		mm	inch.	mm	inch.
<b>APM100/2.5</b>	2.5	89	3.50	42	1.65
<b>APM100/3.5</b>	3.5	93	3.66	44.5	1.75
<b>APM100/4.3</b>	4.3	97	3.82	46	1.81
<b>APM100/5</b>	5	99.5	3.92	47.5	1.87
<b>APM100/6.5</b>	6.5	104.5	4.11	50	1.97
<b>APM100/8</b>	8	110	4.33	53	2.09

Unidirectional gear motor

Type	Order Code	Clockwise rotation: D	Type	Order Code	C.clockwise rotation: S
APM100/2.5 D			APM100/2.5 S		
APM100/3.5 D			APM100/3.5 S		
APM100/4.3 D			APM100/4.3 S		
APM100/5 D			APM100/5 S		
APM100/6.5 D			APM100/6.5 S		
APM100/8 D			APM100/8 S		

Group **APM100** Code **887S NPTF**

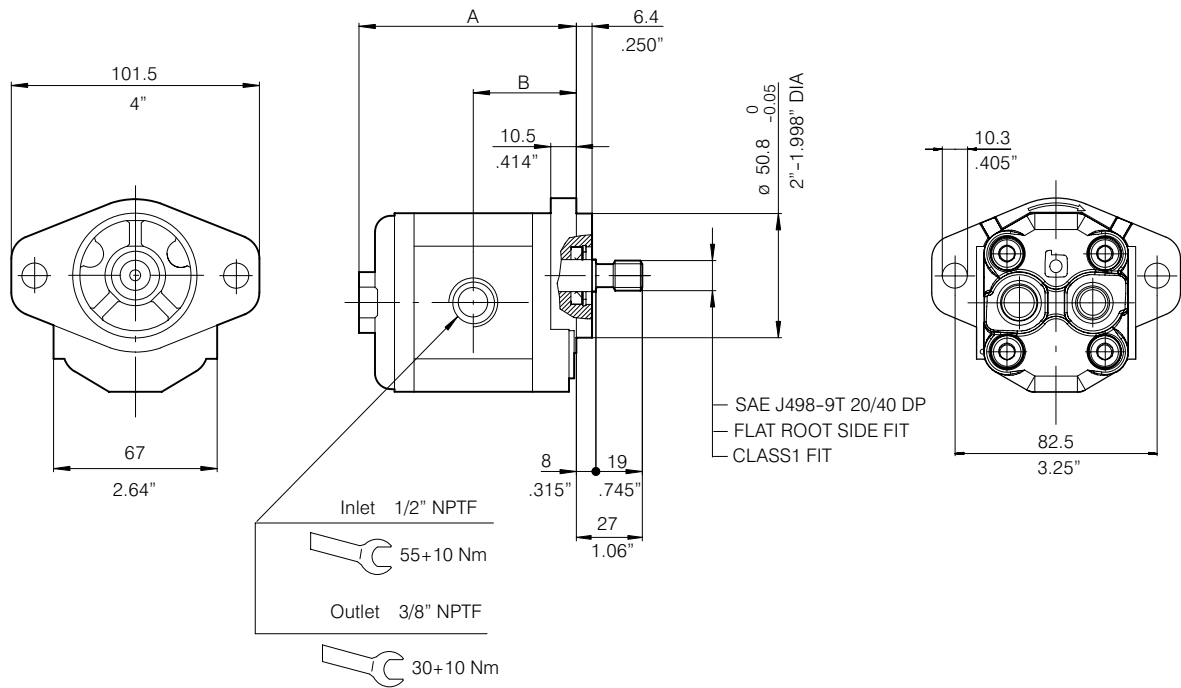

Type	Displacement cm <sup>3</sup> /rev	Dimensions			
		A		B	
		mm	inch.	mm	inch.
<b>APM100/2.5</b>	2.5	89	3.50	42	1.65
<b>APM100/3.5</b>	3.5	93	3.66	44.5	1.75
<b>APM100/4.3</b>	4.3	97	3.82	46	1.81
<b>APM100/5</b>	5	99.5	3.92	47.5	1.87
<b>APM100/6.5</b>	6.5	104.5	4.11	50	1.97
<b>APM100/8</b>	7.8	110	4.33	53	2.09

Unidirectional gear motor

Type	Order Code	Clockwise rotation: D	Type	Order Code	C.clockwise rotation: S
APM100/2.5 D			APM100/2.5 S		
APM100/3.5 D			APM100/3.5 S		
APM100/4.3 D			APM100/4.3 S		
APM100/5 D			APM100/5 S		
APM100/6.5 D			APM100/6.5 S		
APM100/8 D			APM100/8 S		

## 5 Gear motors group APM200

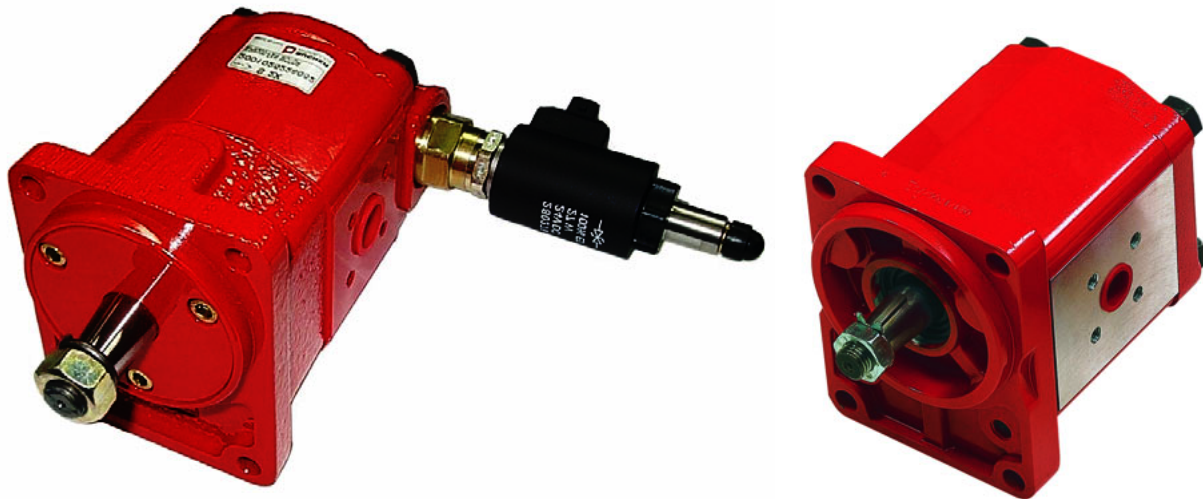

APM200 Type	Displacement		Max. pressure				n min. r/min	n max. r/min
	cm <sup>3</sup> /rev	Cu.In. P.R.	P1		P2			
			bar	P.S.I.	bar	P.S.I.		
APM200/8.5	8.3	.506	220	3150	250	3600	650	4000
APM200/11	11.0	.671	210	3000	250	3600	650	4000
APM200/15	15.0	.915	210	3000	250	3600	650	3500
APM200/19	18.9	1.159	200	2900	240	3400	650	3000
APM200/22	21.9	1.342	190	2750	230	3300	600	3000
APM200/26	25.9	1.586	180	2600	220	3150	600	2500
APFM200/8.5	8.3	.506	220	3150	250	3600	650	4000
APFM200/11	11.0	.671	210	3000	250	3600	650	4000
APFM200/15	15.0	.915	210	3000	250	3600	650	3500
APFM200/19	18.9	1.159	200	2900	240	3400	650	3000
APFM200/22	21.9	1.342	190	2750	230	3300	600	3000
APFM200/26	25.9	1.586	180	2600	220	3150	600	2500
APMR200/8.5	8.3	.506	220	3150	250	3600	650	4000
APMR200/11	11.0	.671	210	3000	250	3600	650	4000
APMR200/15	15.0	.915	210	3000	250	3600	650	3500
APMR200/19	18.9	1.159	200	2900	240	3400	650	3000
APMR200/22	21.9	1.342	190	2750	230	3300	600	3000
APMR200/26	25.9	1.586	180	2600	220	3150	600	2500

### Max torque allowed by the shaft end configuration

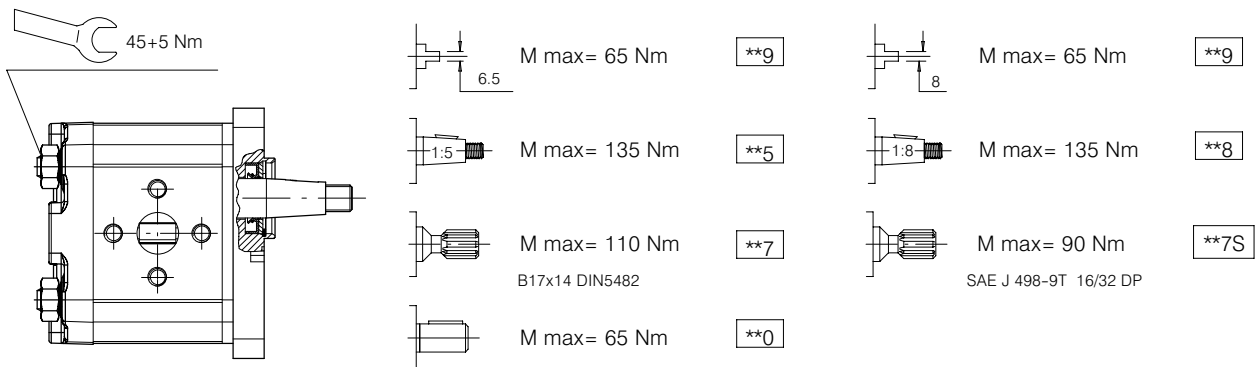

#### Notes:

- For codes and dimensions regarding accessories, see section 6.
- For the types of motors without ordering code, contact our Sales Department.
- For reversible motors inlet and outlet ports have same sizes as per inlet unidirectional rotation

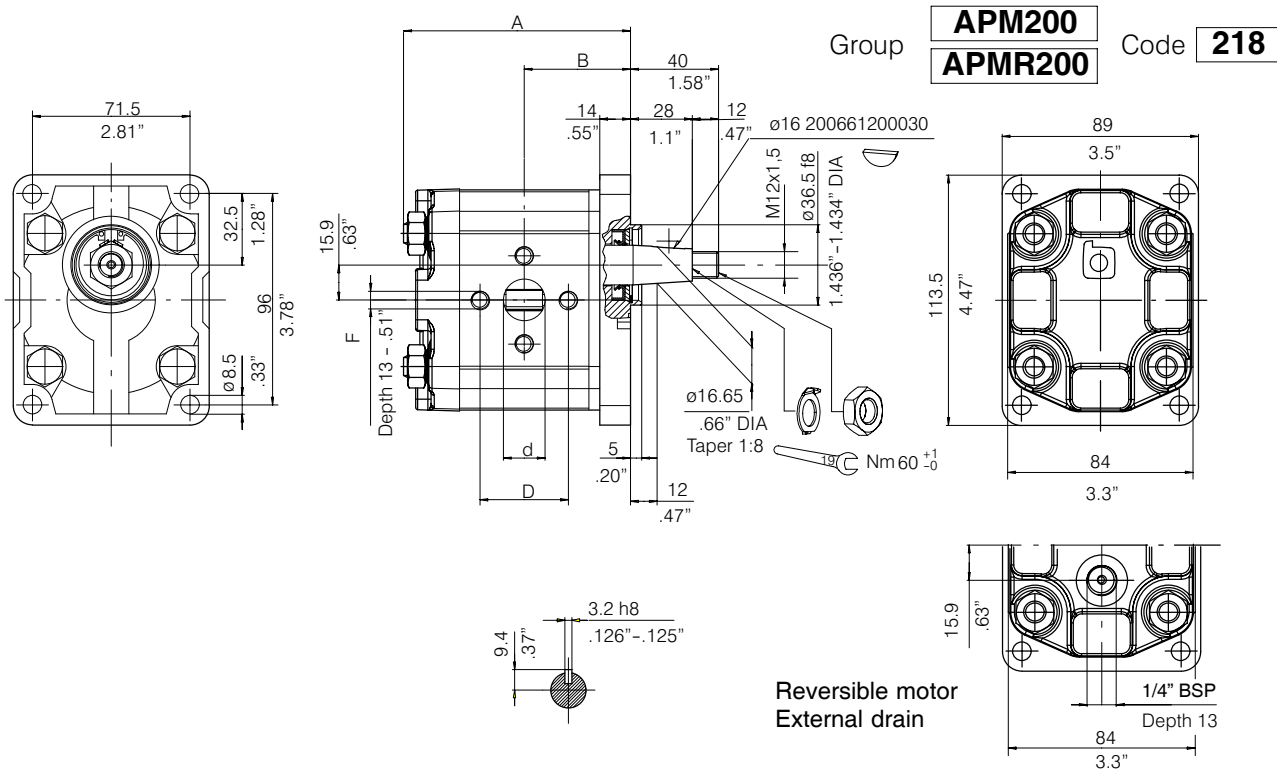

Type	Displacement cm <sup>3</sup> /rev	Dimensions				Outlet					Inlet				
		A		B		d		D		F	d		D		F
		mm	inch	mm	inch	mm	inch	mm	inch	mm	mm	inch	mm	inch	mm
<b>APM200/8.5</b>	8.3	88	3.46	40.3	1.59	13.5	.53	30	1.18	M6X1	13.5	.53	30	1.18	M6X1
<b>APM200/11</b>	10.95	104	4.09	48.3	1.90	19	.75	40	1.58	M8X1.25	19	.75	40	1.58	M8X1.25
<b>APM200/15</b>	14.95														
<b>APM200/19</b>	18.9	114	4.50	54.3	2.14	118	4.64	56.5	2.22	19	.75	40	1.58	M8X1.25	
<b>APM200/22</b>	21.9														
<b>APM200/26</b>	25.9	118	4.64	56.5	2.22	19	.75	40	1.58	M8X1.25	19	.75	40	1.58	M8X1.25

**Unidirectional motor**

Type	Order Code	Clockwise rotation: D	Type	Order Code	Counterclockwise rotation: S
APM200/8.5 D	<b>200.1023.1350.3</b>		APM200/8.5 S	<b>200.1023.1360.4</b>	
APM200/11 D	<b>200.1024.1350.4</b>		APM200/11 S	<b>200.1024.1360.3</b>	
APM200/15 D	<b>200.1025.1350.3</b>		APM200/15 S	<b>200.1025.1360.3</b>	
APM200/19 D	<b>200.1026.1350.3</b>		APM200/19 S	<b>200.1026.1360.2</b>	
APM200/22 D	<b>200.1027.1350.2</b>		APM200/22 S	<b>200.1027.1360.2</b>	
APM200/26 D	<b>200.1028.1350.1</b>		APM200/26 S	<b>200.1028.1360.3</b>	

**Reversible motor**

Type	Order Code	Reversible motor Internal drain	Type	Order Code	Reversible motor External drain
APMR200/8.5 ID			APMR200/8.5 ED		
APMR200/11 ID			APMR200/11 ED		
APMR200/15 ID			APMR200/15 ED		
APMR200/19 ID			APMR200/19 ED		
APMR200/22 ID			APMR200/22 ED		
APMR200/26 ID			APMR200/26 ED		

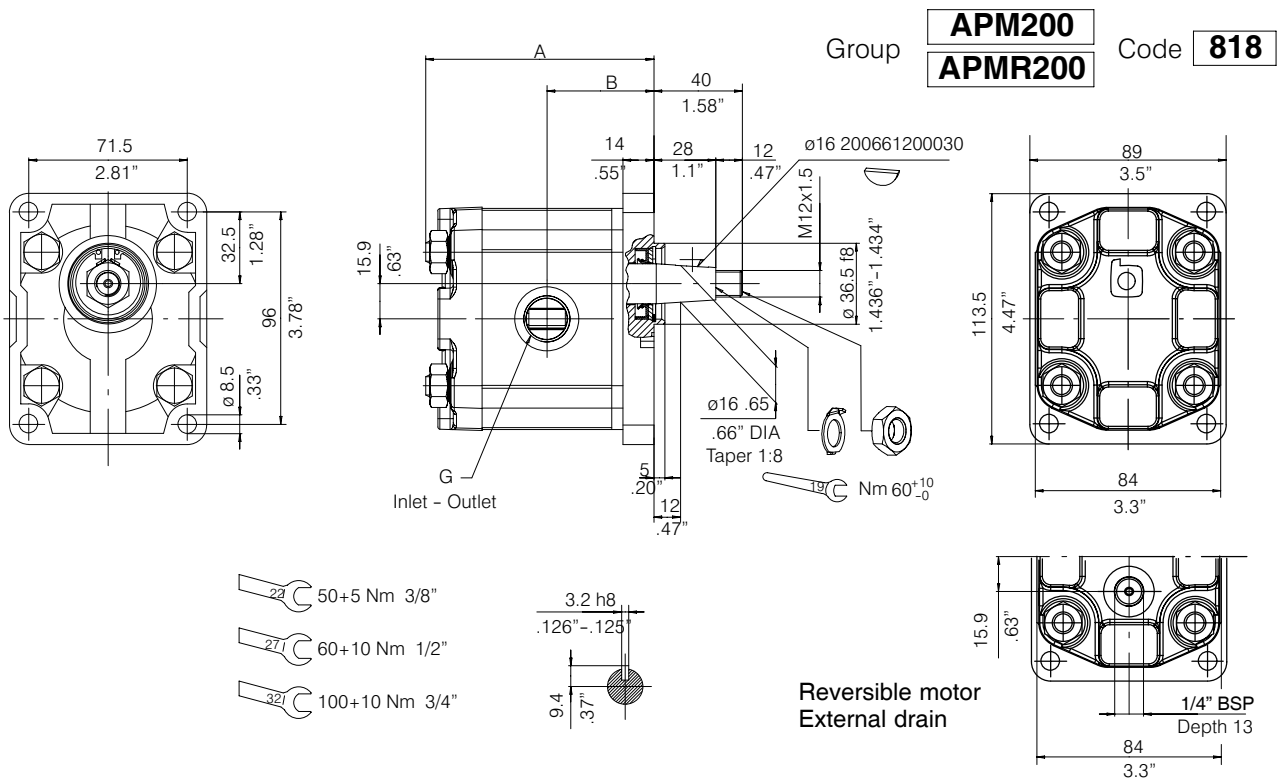

Type	Displacement cm <sup>3</sup> /rev	Dimensions				Outlet	Inlet
		A		B		G	G
		mm	inch.	mm	inch.	BSPP	BSPP
<b>APM200/8.5</b>	8.3	88	3.46	40.3	1.59	3/8"	3/8"
<b>APM200/11</b>	10.95	104	4.09	48.3	1.90	1/2"	
<b>APM200/15</b>	14.95					114	4.50
<b>APM200/19</b>	18.9						
<b>APM200/22</b>	21.9						
<b>APM200/26</b>	25.9	118	4.64	56.5	2.22		1/2"

Unidirectional motor

Type	Order Code	Clockwise rotation: D	Type	Order Code	Counterclockwise rotation: S
APM200/8.5 D	<b>200.1023.1320.7</b>		APM200/8.5 S		
APM200/11 D			APM200/11 S		
APM200/15 D	<b>200.1025.1350.5</b>		APM200/15 S		
APM200/19 D	<b>200.1026.1350.4</b>		APM200/19 S	<b>200.1026.1360.3</b>	
APM200/22 D			APM200/22 S		
APM200/26 D			APM200/26 S		

Reversible motor

Type	Order Code	Reversible motor Internal drain	Type	Order Code	Reversible motor External drain
APMR200/8.5 ID			APMR200/8.5 ED		
APMR200/11 ID			APMR200/11 ED		
APMR200/15 ID			APMR200/15 ED		
APMR200/19 ID			APMR200/19 ED		
APMR200/22 ID			APMR200/22 ED		
APMR200/26 ID			APMR200/26 ED		

Group **APM200** Code **225**  
**APMR200**

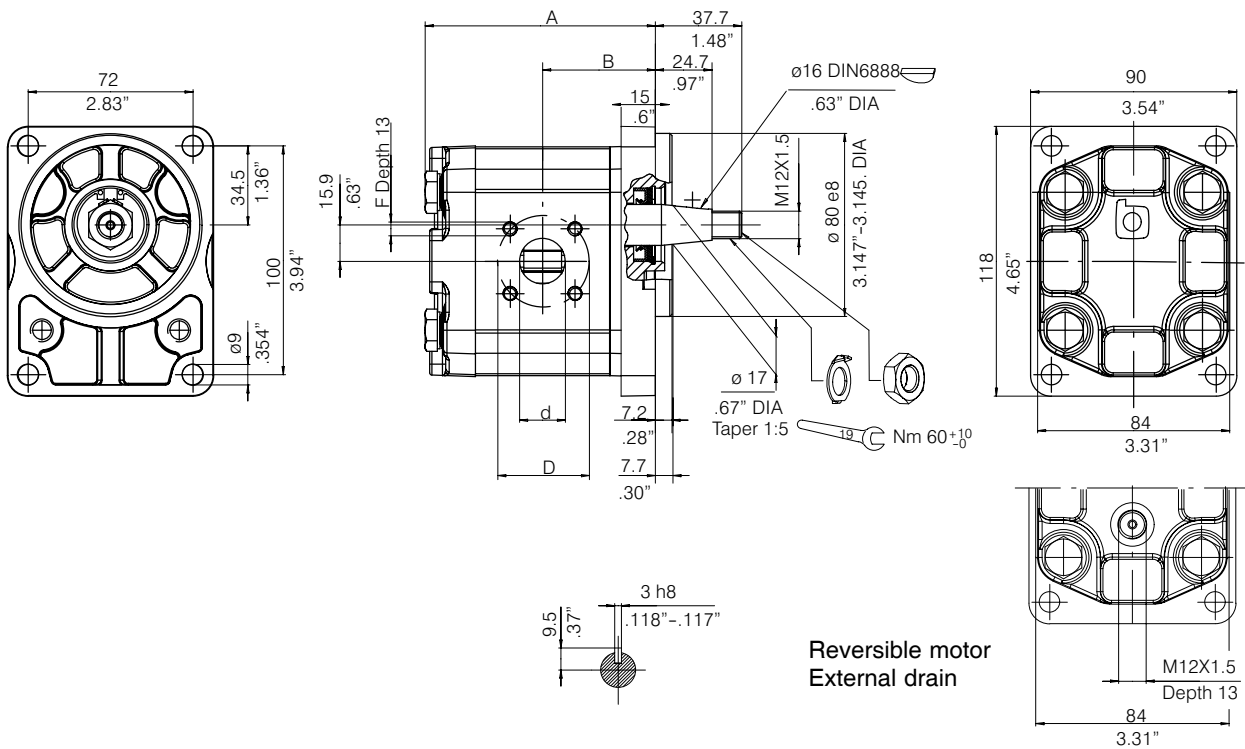

Type	Displacement cm <sup>3</sup> /rev	Dimensions				Outlet					Inlet				
		A		B		d		D		F	d		D	F	
		mm	inch	mm	inch	mm	inch	mm	inch	mm	mm	inch	mm	inch	mm
<b>APM200/8.5</b>	8.3	85	3.35	41.3	1.63	15	.59								
<b>APM200/11</b>	10.95	101	4	49.3	1.94	20	.79	40	1.58	M6X1	15	.59	35	1.38	M6X1
<b>APM200/15</b>	14.95														
<b>APM200/19</b>	18.9	113	4.44	55.3	2.18										
<b>APM200/22</b>	21.9	117	4.60	57.5	2.26										

Unidirectional motor

Type	Order Code	Clockwise rotation: D	Type	Order Code	Counterclockwise rotation: S
APM200/8.5 D	<b>200.1023.2250.1</b>		APM200/8.5 S		
APM200/11 D	<b>200.1024.2250.3</b>		APM200/11 S	<b>200.1024.2260.1</b>	
APM200/15 D			APM200/15 S		
APM200/19 D			APM200/19 S		
APM200/22 D			APM200/22 S		

Reversible motor

Type	Order Code	Reversible motor Internal drain	Type	Order Code	Reversible motor External drain
APMR200/8.5 ID			APMR200/8.5 ED		
APMR200/11 ID			APMR200/11 ED		
APMR200/15 ID			APMR200/15 ED		
APMR200/19 ID			APMR200/19 ED		
APMR200/22 ID			APMR200/22 ED		

Group **APM200** Code **227**  
**APMR200**

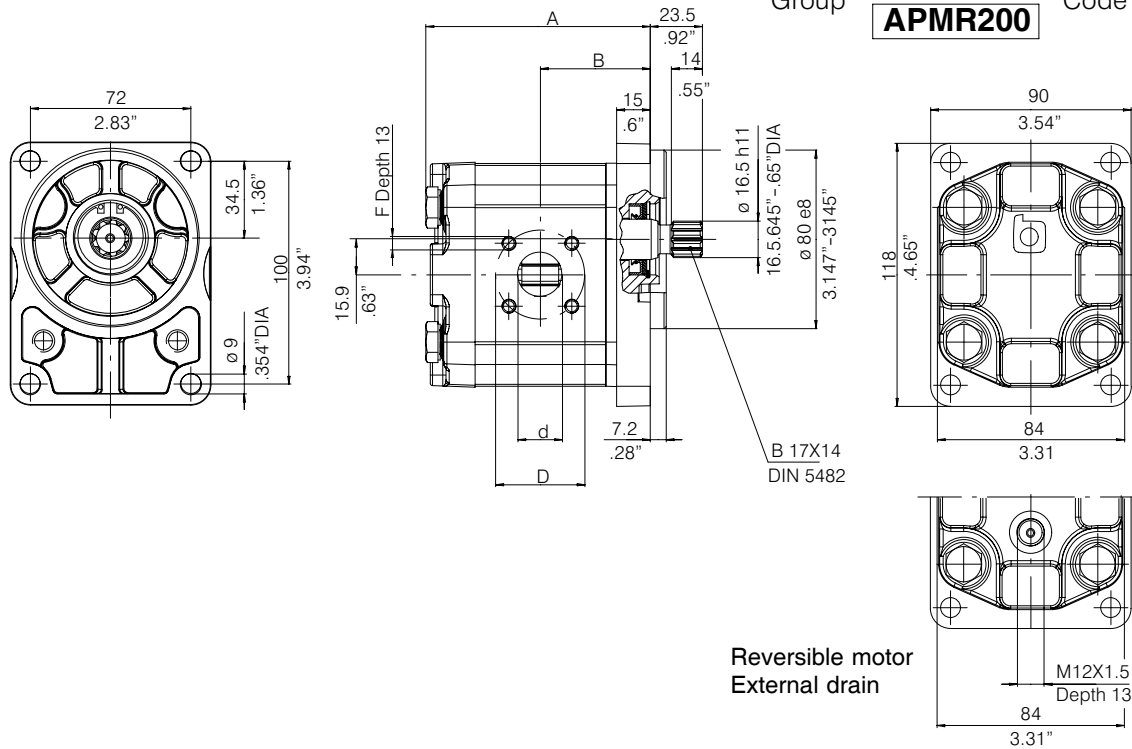

Type	Displacement cm <sup>3</sup> /rev	Dimensions				Outlet			Inlet						
		A		B		d	D	F	d	D	F				
		mm	inch	mm	inch	mm	inch	mm	mm	inch	mm				
<b>APM200/8.5</b>	8.3	85	3.35	41.3	1.63	15	.59	40	1.58	M6X1	15	.59	35	1.38	M6X1
<b>APM200/11</b>	10.95	101	4	49.3	1.94	20	.79								
<b>APM200/15</b>	14.95														
<b>APM200/19</b>	18.9	113	4.44	55.3	2.18										
<b>APM200/22</b>	21.9	117	4.60	57.5	2.26										
<b>APM200/26</b>	25.9														

Unidirectional motor

Type	Order Code	Clockwise rotation: D	Type	Order Code	Counterclockwise rotation: S
APM200/8.5 D	<b>200.1024.2520.3</b>		APM200/8.5 S	<b>200.1023.2560.2</b>	
APM200/11 D			APM200/11 S		
APM200/15 D			APM200/15 S		
APM200/19 D			APM200/19 S	<b>200.1026.2560.1</b>	
APM200/22 D			APM200/22 S	<b>200.1027.2530.3</b>	
APM200/26 D			APM200/26 S	<b>200.1028.2530.2</b>	

Reversible motor

Type	Order Code	Reversible motor Internal drain	Type	Order Code	Reversible motor External drain
APMR200/8.5 ID			APMR200/8.5 ED		
APMR200/11 ID			APMR200/11 ED		
APMR200/15 ID			APMR200/15 ED		
APMR200/19 ID			APMR200/19 ED		
APMR200/22 ID			APMR200/22 ED		
APMR200/26 ID			APMR200/26 ED		

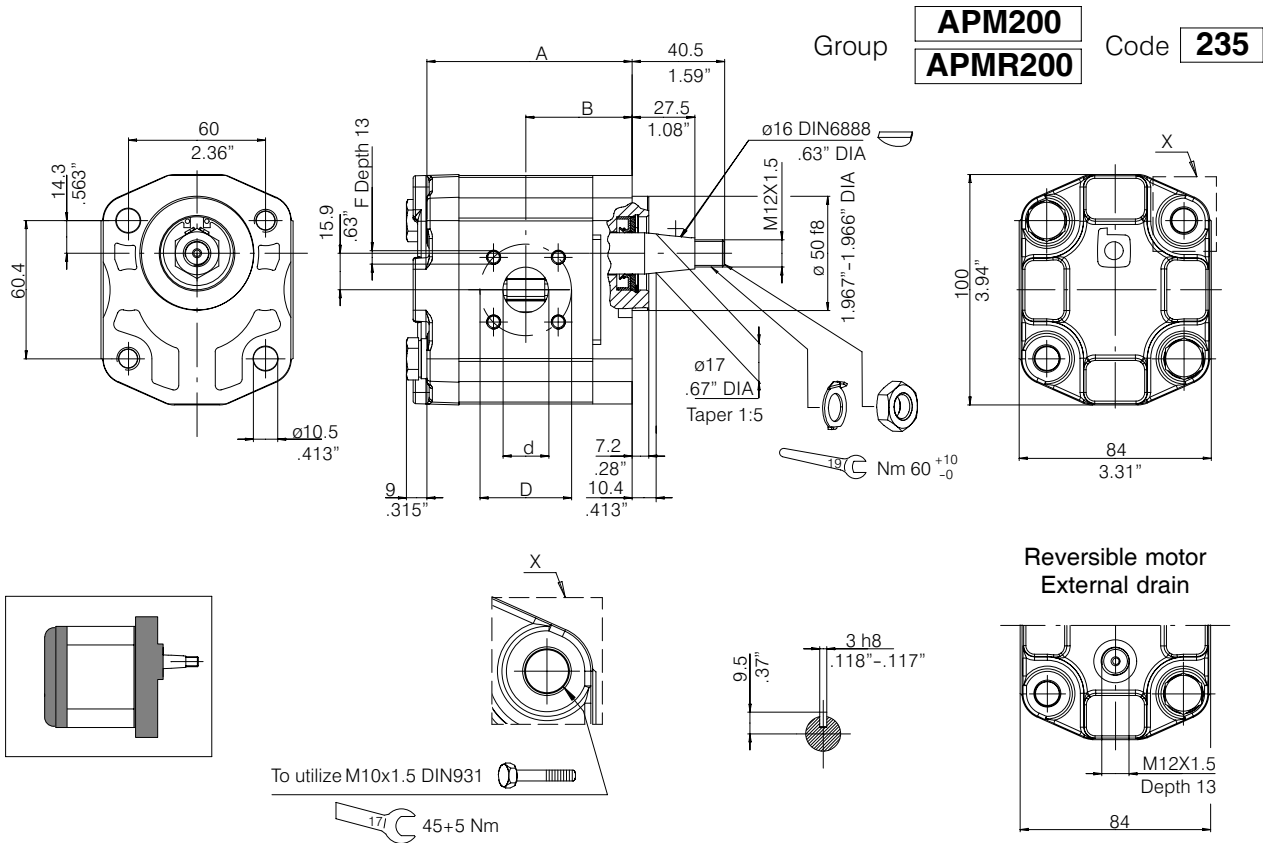

Group **APM200**  
**APMR200**

Code **235**

Reversible motor  
External drain

Type	Displacement cm <sup>3</sup> /rev	Dimensions				Outlet					Inlet				
		A		B		d		D		F	d		D		F
		mm	inch	mm	inch	mm	inch	mm	inch	mm	mm	inch	mm	inch	mm
<b>APM200/8.5</b>	8.3	74	2.9	40	1.57	15	.59								
<b>APM200/11</b>	10.95	90	3.55	46.5	1.83	20	.79	40	1.58	M6X1	15	.59	35	1.38	M6X1
<b>APM200/15</b>	14.95														
<b>APM200/19</b>	18.9	102	4	52.3	2.06										
<b>APM200/22</b>	21.9	106	4.17	54.5	2.15	20	.79	40	1.58	M6X1	15	.59	35	1.38	M6X1

Unidirectional motor

Type	Order Code	Clockwise rotation: D	Type	Order Code	Counterclockwise rotation: S
APM200/8.5 D			APM200/8.5 S	<b>200.1023.3260.1</b>	
APM200/11 D			APM200/11 S	<b>200.1024.3260.1</b>	
APM200/15 D			APM200/15 S		
APM200/19 D			APM200/19 S		
APM200/22 D			APM200/22 S		

Reversible motor

Type	Order Code	Reversible motor Internal drain	Type	Order Code	Reversible motor External drain
APMR200/8.5 ID			APMR200/8.5 ED		
APMR200/11 ID			APMR200/11 ED		
APMR200/15 ID			APMR200/15 ED		
APMR200/19 ID			APMR200/19 ED		
APMR200/22 ID			APMR200/22 ED		

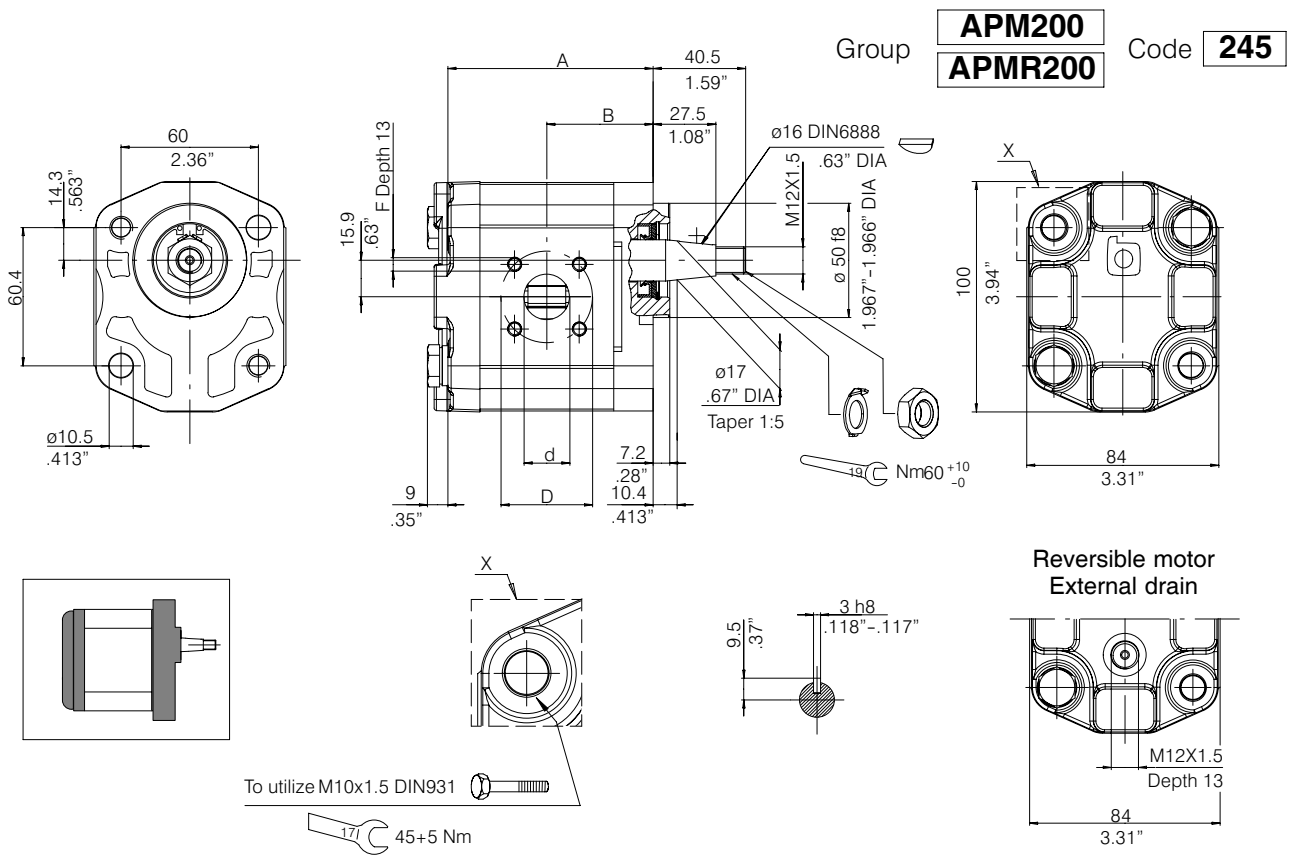

Type	Displacement cm <sup>3</sup> /rev	Dimensions				Outlet					Inlet				
		A		B		d		D		F	d		D	F	
		mm	inch	mm	inch	mm	inch	mm	inch	mm	mm	inch	mm	inch	mm
<b>APM200/8.5</b>	8.3	74	2.9	40	1.57	15	.59	40	1.58	M6X1	15	.59	35	1.38	M6X1
<b>APM200/11</b>	10.95	90	3.55	46.5	1.83	20	.79								
<b>APM200/15</b>	14.95														
<b>APM200/19</b>	18.9														
<b>APM200/22</b>	21.9														

**Unidirectional motor**

Type	Order Code	Clockwise rotation: D	Type	Order Code	Counterclockwise rotation: S
APM200/8.5 D			APM200/8.5 S		
APM200/11 D			APM200/11 S		
APM200/15 D			APM200/15 S		
APM200/19 D			APM200/19 S		
APM200/22 D			APM200/22 S		

**Reversible motor**

Type	Order Code	Reversible motor Internal drain	Type	Order Code	Reversible motor External drain
APMR200/8.5 ID			APMR200/8.5 ED		
APMR200/11 ID			APMR200/11 ED		
APMR200/15 ID			APMR200/15 ED		
APMR200/19 ID			APMR200/19 ED		
APMR200/22 ID			APMR200/22 ED		



Group **APM200** Code **247**  
**APMR200**

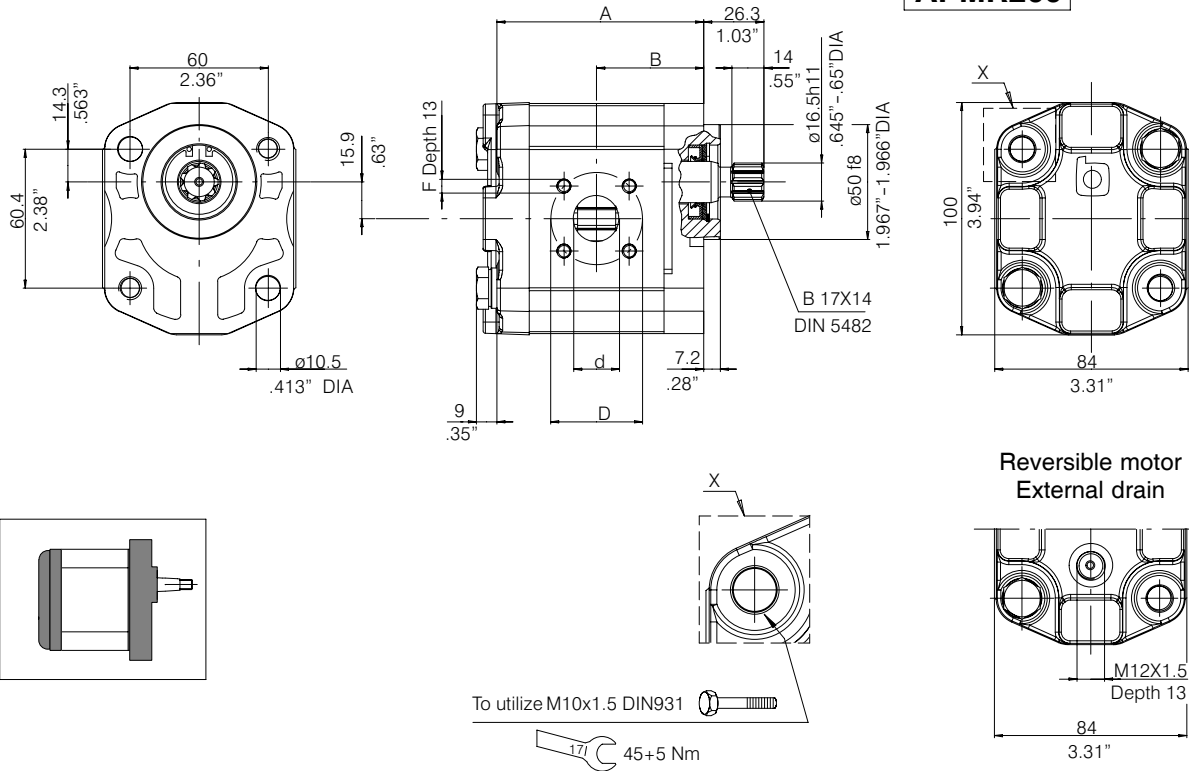

Reversible motor  
External drain

Type	Displacement cm <sup>3</sup> /rev	Dimensions				Outlet					Inlet				
		A		B		d		D		F	d		D	F	
		mm	inch	mm	inch	mm	inch	mm	inch	mm	mm	inch	mm	inch	mm
<b>APM200/8.5</b>	8.3	74	2.9	40	1.57	15	.59	40	1.58	M6X1	15	.59	35	1.38	M6X1
<b>APM200/11</b>	10.95	90	3.55	46.5	1.83	20	.79								
<b>APM200/15</b>	14.95	102	4	52.3	2.06										
<b>APM200/19</b>	18.9	106	4.17	54.5	2.15										
<b>APM200/22</b>	21.9														

Unidirectional motor

Type	Order Code	Clockwise rotation: D	Type	Order Code	Counterclockwise rotation: S
APM200/8.5 D			APM200/8.5 S		
APM200/11 D			APM200/11 S		
APM200/15 D			APM200/15 S		
APM200/19 D			APM200/19 S		
APM200/22 D			APM200/22 S		

Reversible motor

Type	Order Code	Reversible motor Internal drain	Type	Order Code	Reversible motor External drain
APMR200/8.5 ID			APMR200/8.5 ED		
APMR200/11 ID			APMR200/11 ED		
APMR200/15 ID			APMR200/15 ED		
APMR200/19 ID			APMR200/19 ED		
APMR200/22 ID			APMR200/22 ED		

Group **APM200** Code **887S**  
**APMR200**

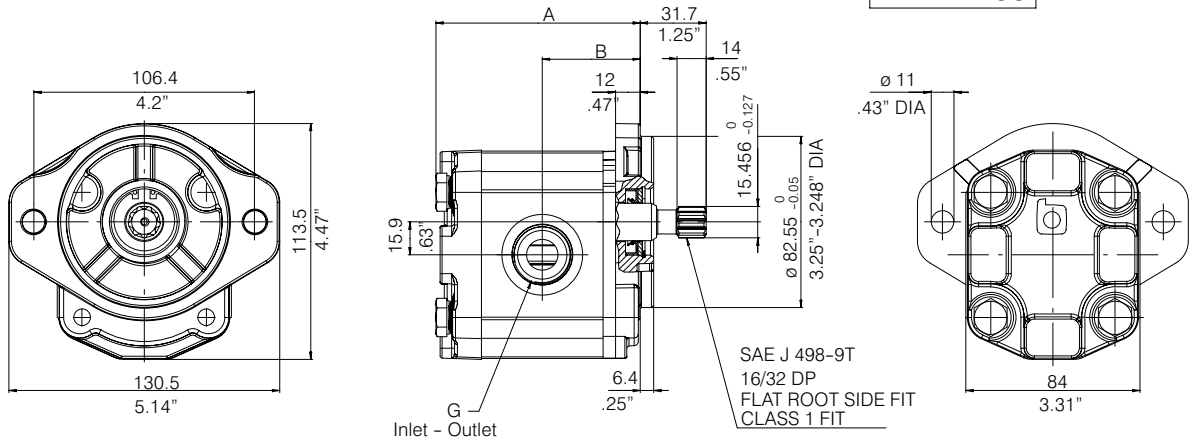

100+10 Nm 1-1/16 12UNF

65+10 Nm 7/8 14UNF

Reversible motor  
External drain

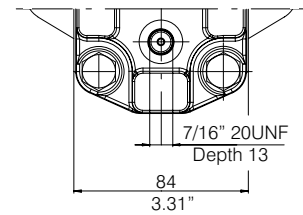

Type	Displacement cm <sup>3</sup> /rev	Dimensions				Outlet	Inlet
		A		B		G	G
		mm	inch	mm	inch	12UNF	14UNF
<b>APM200/8.5</b>	8.3	82.5	3.23	39.5	1.55	1-1/16	7/8
<b>APM200/11</b>	10.95	98.5	3.9	47.5	1.87		
<b>APM200/15</b>	14.95						
<b>APM200/19</b>	18.9	110.5	4.35	53.5	2.11		
<b>APM200/22</b>	21.9	115	4.53	55.5	2.18		
<b>APM200/26</b>	25.9						

Unidirectional motor

Type	Order Code	Clockwise rotation: D	Type	Order Code	Counterclockwise rotation: S
APM200/8.5 D	<b>200.1023.8650.1</b>		APM200/8.5 S		
APM200/11 D	<b>200.1024.8650.1</b>		APM200/11 S		
APM200/15 D			APM200/15 S		
APM200/19 D	<b>200.1026.8650.2</b>		APM200/19 S		
APM200/22 D			APM200/22 S		
APM200/26 D			APM200/26 S		

Reversible motor

Type	Order Code	Reversible motor Internal drain	Type	Order Code	Reversible motor External drain
APMR200/8.5 ID			APMR200/8.5 ED		
APMR200/11 ID			APMR200/11 ED		
APMR200/15 ID			APMR200/15 ED		
APMR200/19 ID			APMR200/19 ED		
APMR200/22 ID			APMR200/22 ED		
APMR200/26 ID			APMR200/26 ED		

Group **APM200**  
**APMR200**

Code **880**

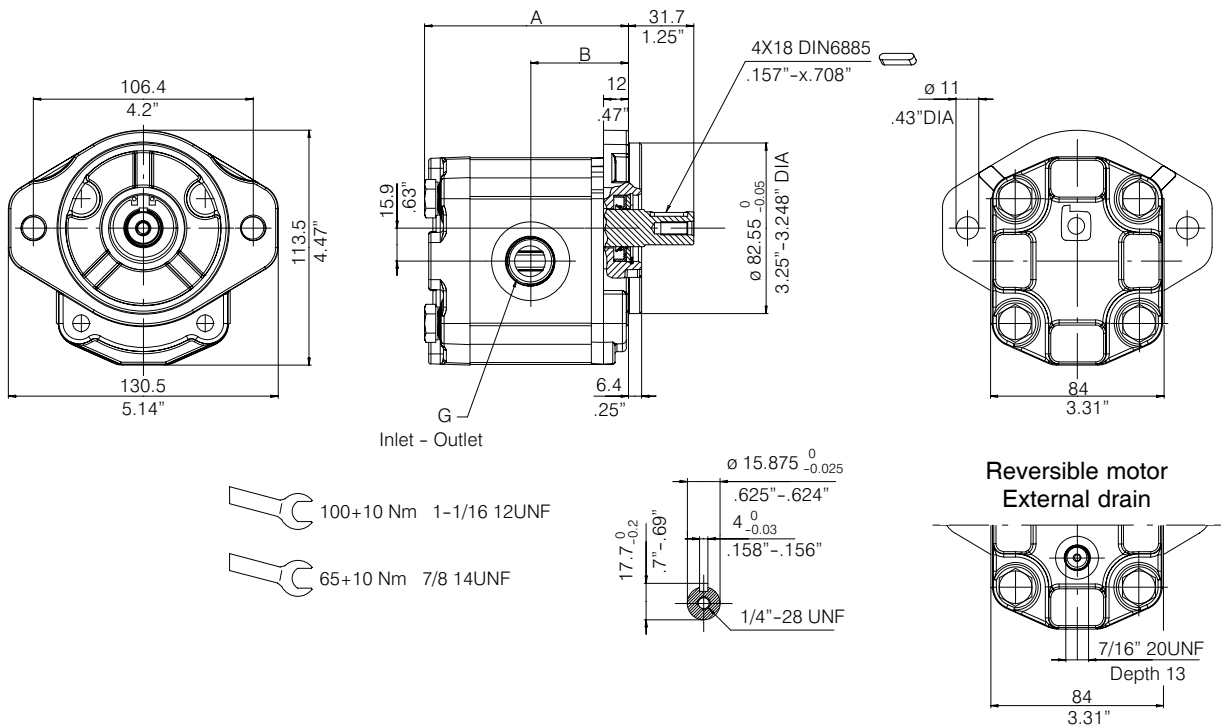

100+10 Nm 1-1/16 12UNF  
 65+10 Nm 7/8 14UNF

Type	Displacement cm <sup>3</sup> /rev	Dimensions				Outlet	Inlet
		A		B		G	G
		mm	inch	mm	inch	12UNF	14UNF
<b>APM200/8.5</b>	8.3	82.5	3.23	39.5	1.55	1-1/16	7/8
<b>APM200/11</b>	10.95	98.5	3.9	47.5	1.87		
<b>APM200/15</b>	14.95						
<b>APM200/19</b>	18.9	110.5	4.35	53.5	2.11		
<b>APM200/22</b>	21.9	115	4.53	55.5	2.18		
<b>APM200/26</b>	25.9						

Unidirectional motor

Type	Order Code	Clockwise rotation: D	Type	Order Code	Counterclockwise rotation: S
APM200/8.5 D	<b>200.1023.8050.2</b>		APM200/8.5 S	<b>200.1023.8060.1</b>	
APM200/11 D	<b>200.1024.8050.1</b>		APM200/11 S	<b>200.1024.8060.2</b>	
APM200/15 D	<b>200.1025.8050.3</b>		APM200/15 S	<b>200.1025.8060.1</b>	
APM200/19 D	<b>200.1026.8050.1</b>		APM200/19 S		
APM200/22 D	<b>200.1027.8050.1</b>		APM200/22 S		
APM200/26 D	<b>200.1028.8050.1</b>		APM200/26 S		

Reversible motor

Type	Order Code	Reversible motor Internal drain	Type	Order Code	Reversible motor External drain
APMR200/8.5 ID			APMR200/8.5 ED		
APMR200/11 ID			APMR200/11 ED		
APMR200/15 ID			APMR200/15 ED		
APMR200/19 ID			APMR200/19 ED		
APMR200/22 ID			APMR200/22 ED		
APMR200/26 ID			APMR200/26 ED		

Group **APM200** Code **887S NPTF**  
**APMR200**

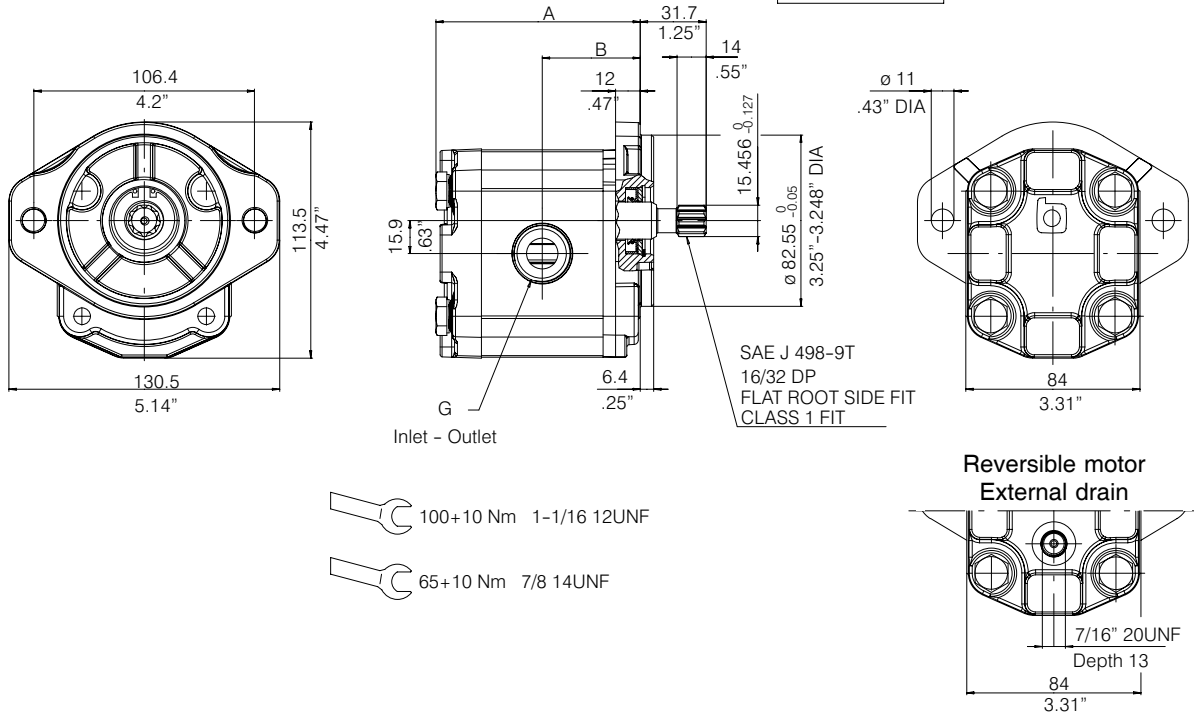

Type	Displacement cm <sup>3</sup> /rev	Dimensions				Outlet	Inlet
		A		B		G	G
		mm	inch	mm	inch	NPTF	NPTF
<b>APM200/11</b>	10.95	98.5	3.9	47.5	1.87	3/4"	1/2"
<b>APM200/15</b>	14.95						
<b>APM200/19</b>	18.9	110.5	4.35	53.5	2.11		
<b>APM200/22</b>	21.9	115	4.53	55.5	2.18		
<b>APM200/26</b>	25.9						

**Unidirectional motor**

Type	Order Code	Clockwise rotation: D	Type	Order Code	Counterclockwise rotation: S
APM200/11 D			APM200/11 S		
APM200/15 D					
APM200/19 D					
APM200/22 D					
APM200/26 D					

**Reversible motor**

Type	Order Code	Reversible motor Internal drain	Type	Order Code	Reversible motor External drain
APMR200/11 ID			APMR200/11 ED		
APMR200/15 ID					
APMR200/19 ID					
APMR200/22 ID					
APMR200/26 ID					

Group **APM200** Code **880 NPTF**  
**APMR200**

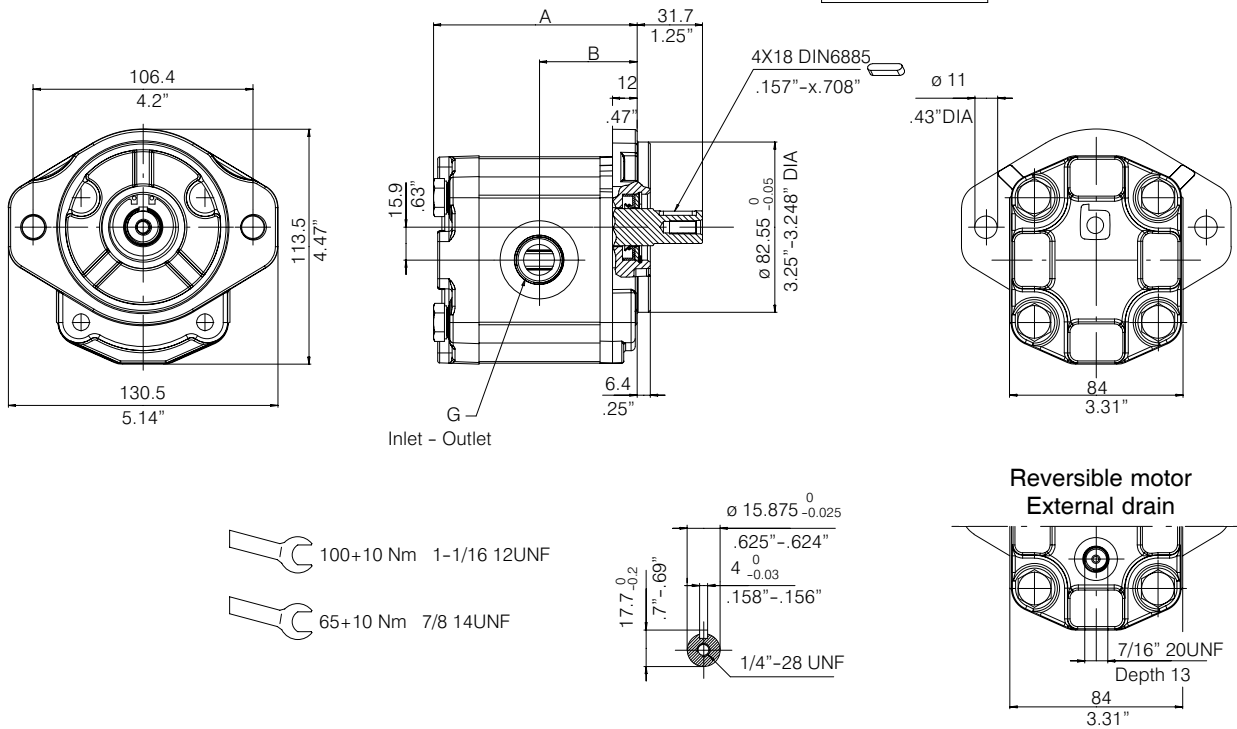

100+10 Nm 1-1/16 12UNF  
 65+10 Nm 7/8 14UNF

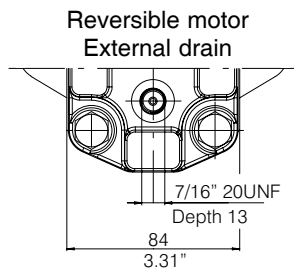

Type	Displacement cm <sup>3</sup> /rev	Dimensions				Outlet	Inlet
		A		B		G	G
		mm	inch	mm	inch	NPTF	NPTF
<b>APM200/8.5</b>	8.3	82.5	3.23	39.5	1.55	1/2"	1/2"
<b>APM200/11</b>	10.95	98.5	3.9	47.5	1.87	3/4"	1/2"
<b>APM200/15</b>	14.95						
<b>APM200/19</b>	18.9	110.5	4.35	53.5	2.11		
<b>APM200/22</b>	21.9	115	4.53	55.5	2.18		
<b>APM200/26</b>	25.9						

**Unidirectional motor**

Type	Order Code	Clockwise rotation: D	Type	Order Code	Counterclockwise rotation: S
APM200/8.5 D			APM200/8.5 S		
APM200/11 D					
APM200/15 D					
APM200/19 D					
APM200/22 D					
APM200/26 D					

**Reversible motor**

Type	Order Code	Reversible motor Internal drain	Type	Order Code	Reversible motor External drain
APMR200/8.5 ID			APMR200/8.5 ED		
APMR200/11 ID					
APMR200/15 ID					
APMR200/19 ID					
APMR200/22 ID					
APMR200/26 ID					

Group **APM200** Code **287S-B**  
**APMR200**

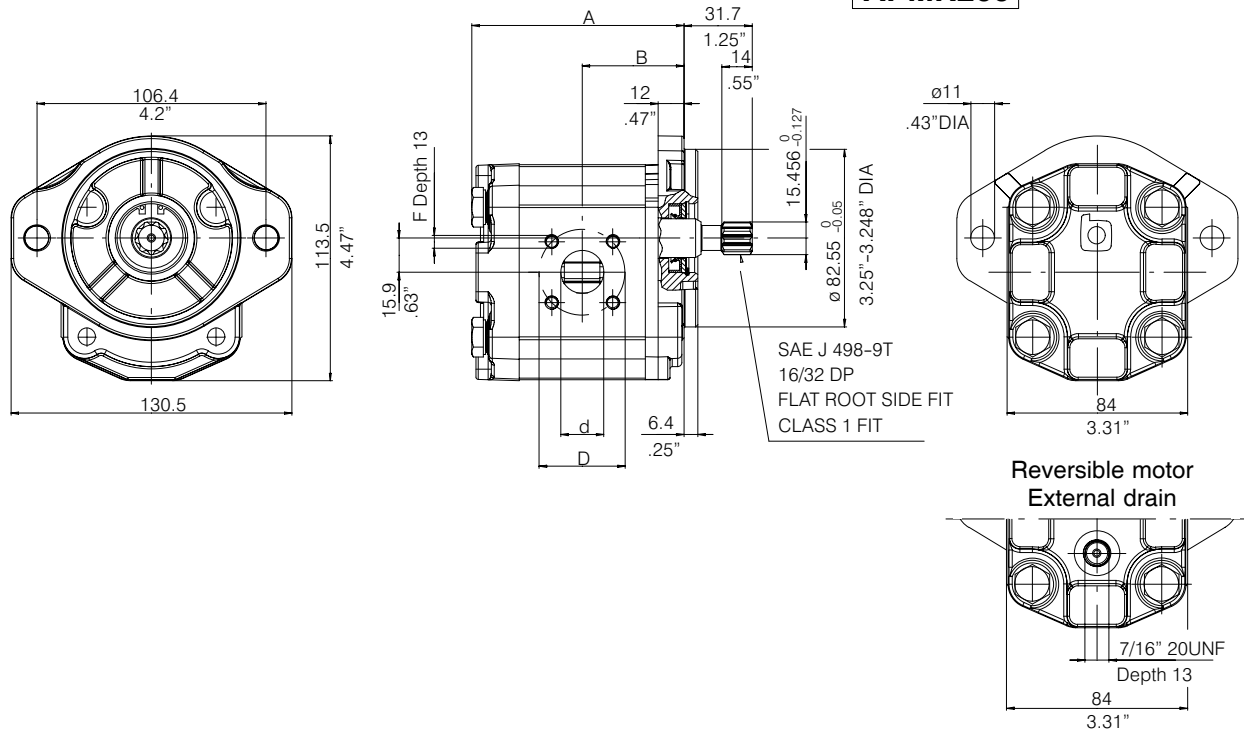

Reversible motor  
External drain

Type	Displacement cm <sup>3</sup> /rev	Dimensions				Outlet			Inlet						
		A		B		d	D	F	d	D	F				
		mm	inch	mm	inch	mm	inch	mm	mm	inch	mm				
<b>APM200/8.5</b>	8.3	82.5	3.23	39.5	1.55	15	.59								
<b>APM200/11</b>	10.95	98.5	3.9	47.5	1.87	20	.79	40	1.58	M6X1	13.5	.53	35	1.38	M6X1
<b>APM200/15</b>	14.95														
<b>APM200/19</b>	18.9	110.5	4.35	53.5	2.11										
<b>APM200/22</b>	21.9	115	4.53	55.5	2.18										
<b>APM200/26</b>	25.9														

Unidirectional motor

Type	Order Code	Clockwise rotation: D	Type	Order Code	Counterclockwise rotation: S
APM200/8.5 D			APM200/8.5 S		
APM200/11 D			APM200/11 S		
APM200/15 D			APM200/15 S		
APM200/19 D			APM200/19 S		
APM200/22 D			APM200/22 S		
APM200/26 D	<b>200.1028.8650.1</b>		APM200/26 S		

Reversible motor

Type	Order Code	Reversible motor Internal drain	Type	Order Code	Reversible motor External drain
APMR200/8.5 ID			APMR200/8.5 ED		
APMR200/11 ID			APMR200/11 ED		
APMR200/15 ID			APMR200/15 ED		
APMR200/19 ID			APMR200/19 ED		
APMR200/22 ID			APMR200/22 ED		
APMR200/26 ID			APMR200/26 ED		

Group **APM200** Code **280B**  
**APMR200**

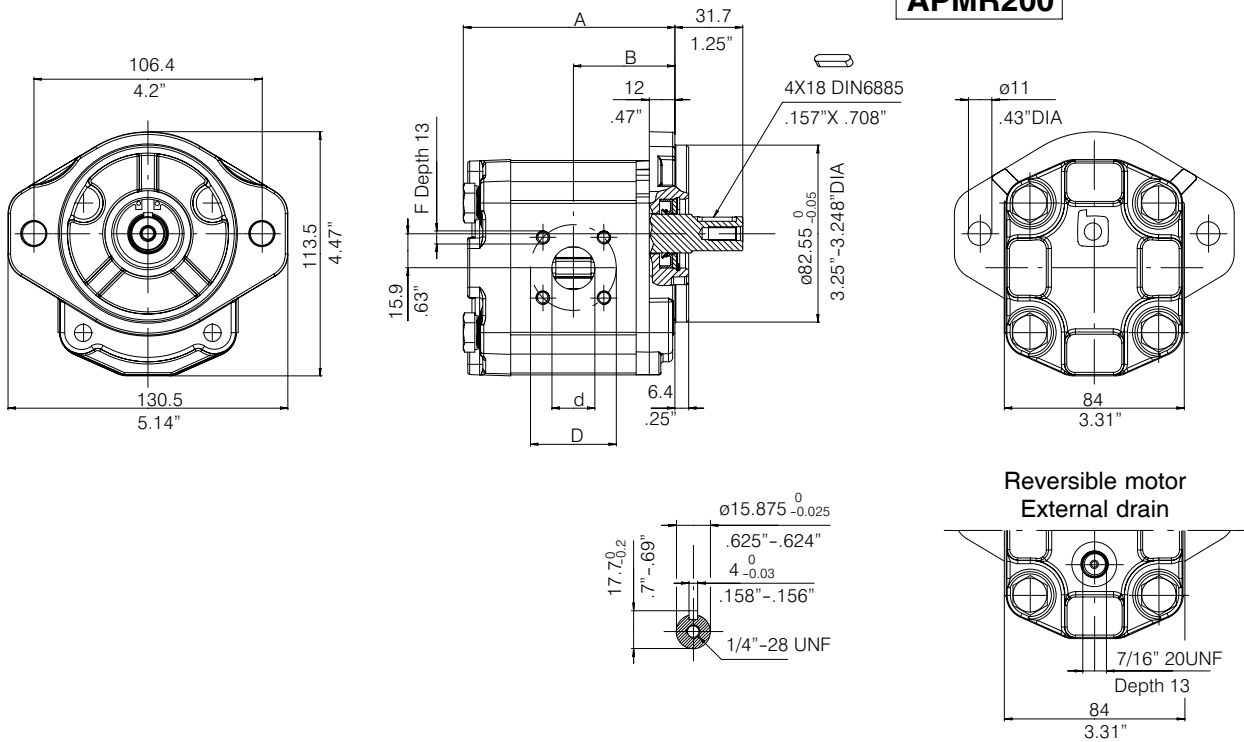

Type	Displacement cm <sup>3</sup> /rev	Dimensions				Outlet					Inlet				
		A		B		d		D		F	d		D		F
		mm	inch	mm	inch	mm	inch	mm	inch	mm	mm	inch	mm	inch	mm
<b>APM200/8.5</b>	8.3	82.5	3.23	39.5	1.55	15	.59								
<b>APM200/11</b>	10.95	98.5	3.9	47.5	1.87	20	.79	40	1.58	M6X1	13.5	.53	35	1.38	M6X1
<b>APM200/15</b>	14.95														
<b>APM200/19</b>	18.9	110.5	4.35	53.5	2.11										
<b>APM200/22</b>	21.9	115	4.53	55.5	2.18										
<b>APM200/26</b>	25.9														

**Unidirectional motor**

Type	Order Code	Clockwise rotation: D	Type	Order Code	Counterclockwise rotation: S
APM200/8.5 D			APM200/8.5 S		
APM200/11 D			APM200/11 S		
APM200/15 D			APM200/15 S		
APM200/19 D			APM200/19 S		
APM200/22 D			APM200/22 S		
APM200/26 D			APM200/26 S		

**Reversible motor**

Type	Order Code	Reversible motor Internal drain	Type	Order Code	Reversible motor External drain
APMR200/8.5 ID			APMR200/8.5 ED		
APMR200/11 ID			APMR200/11 ED		
APMR200/15 ID			APMR200/15 ED		
APMR200/19 ID			APMR200/19 ED		
APMR200/22 ID			APMR200/22 ED		
APMR200/26 ID			APMR200/26 ED		

Group **APM200** Code **225 2K2**

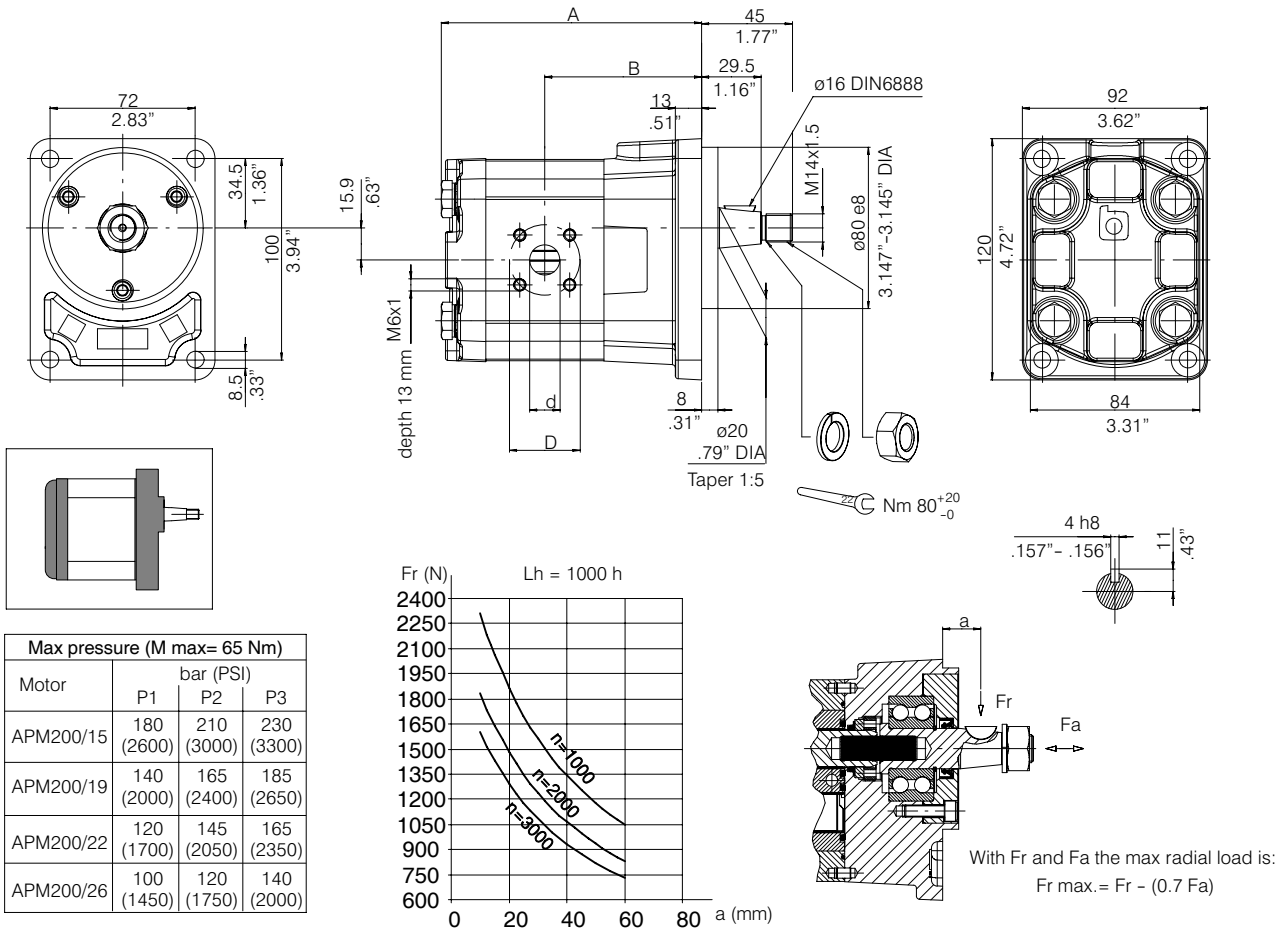

Type	Displacement cm <sup>3</sup> /rev	Dimensions				Outlet			Inlet						
		A		B		d	D		F	d	D		F		
		mm	inch	mm	inch	mm	inch	mm	mm	inch	mm	inch	mm		
<b>APM200/8.5</b>	8.3	113	4.45	70	2.75	15	.59	40	1.58	M6X1	15	.59	35	1.38	M6X1
<b>APM200/11</b>	10.95	129	5.08	78	3.06	20	.79								
<b>APM200/15</b>	14.95														
<b>APM200/19</b>	18.9	141	5.55	84	3.30										
<b>APM200/22</b>	21.9	145.5	5.73	86	3.39										
<b>APM200/26</b>	25.9														

Unidirectional motor

Type	Order Code	Clockwise rotation: D	Type	Order Code	Counterclockwise rotation: S
APM200/8.5 D			APM200/8.5 S		
APM200/11 D			APM200/11 S		
APM200/15 D			APM200/15 S		
APM200/19 D			APM200/19 S		
APM200/22 D			APM200/22 S		
APM200/26 D			APM200/26 S		

N.B.: With respect to the standards, the maximum pressures of some versions of this motor are reduced in relation to the max. torque allowed to the shaft.

Group **APMR200** Code **225 2K1**

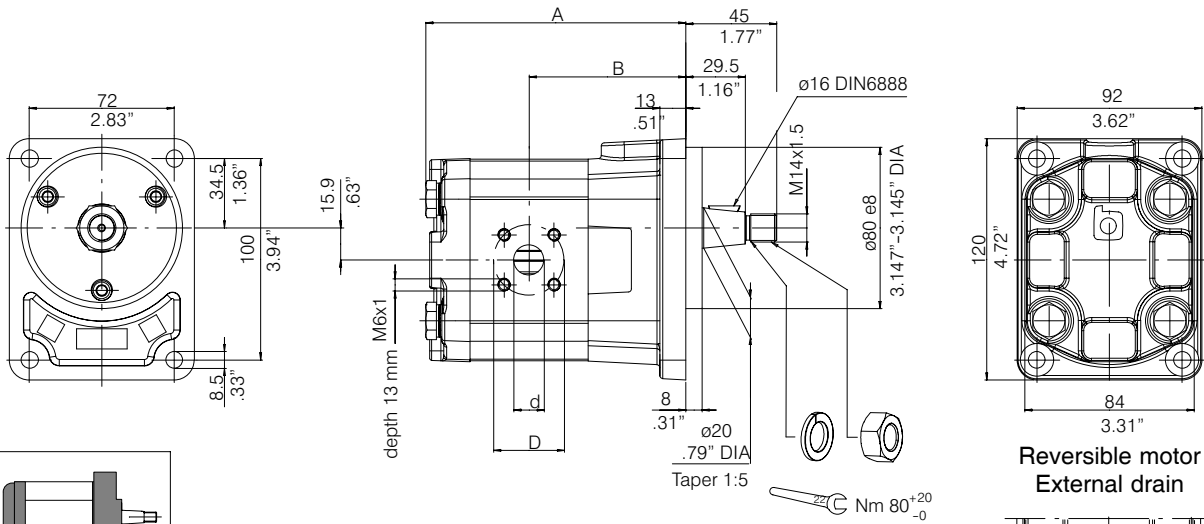

Reversible motor  
External drain

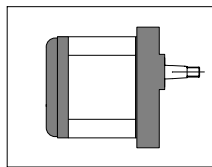

Max pressure (M max= 65 Nm)			
Motor	P1	P2	P3
APMR200/15	180 (2600)	210 (3000)	230 (3300)
APMR200/19	140 (2000)	165 (2400)	185 (2650)
APMR200/22	120 (1700)	145 (2050)	165 (2350)
APMR200/26	100 (1450)	120 (1750)	140 (2000)

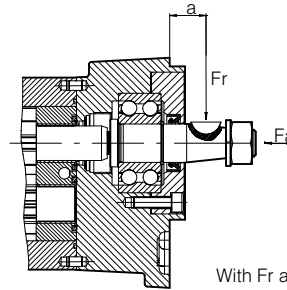
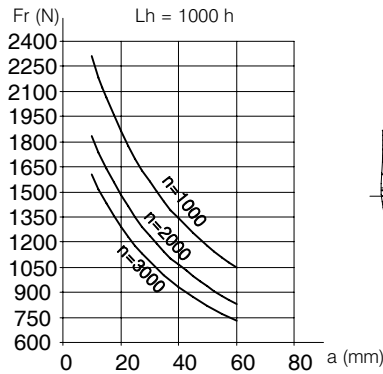

With Fr and Fa the max radial load is:  
 $Fr_{max} = Fr - (0.7 Fa)$

Type	Displacement cm <sup>3</sup> /rev	Dimensions				Outlet					Inlet				
		A		B		d		D		F	d		D		F
		mm	inch	mm	inch	mm	inch	mm	inch	mm	mm	inch	mm	inch	mm
<b>APMR200/8.5</b>	8.3	113	4.45	70	2.75	15	.59	35	1.38	M6X1	15	.59	35	1.38	M6X1
<b>APMR200/11</b>	10.95	129	5.08	78	3.06										
<b>APMR200/15</b>	14.95														
<b>APMR200/19</b>	18.9	141	5.55	84	3.30										
<b>APMR200/22</b>	21.9	145.5	5.73	86	3.39										
<b>APMR200/26</b>	25.9														

Reversible motor

Type	Order Code	Reversible motor Internal drain	Type	Order Code	Reversible motor External drain
APMR200/8.5 ID			APMR200/8.5 ED		
APMR200/11 ID			APMR200/11 ED		
APMR200/15 ID			APMR200/15 ED		
APMR200/19 ID			APMR200/19 ED		
APMR200/22 ID			APMR200/22 ED		
APMR200/26 ID			APMR200/26 ED		

N.B.: With respect to the standards, the maximum pressures of some versions of this motor are reduced in relation to the max. torque allowed to the shaft.

Group **APM200** Code **220 2T2**

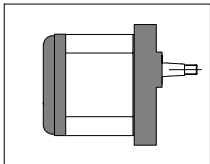
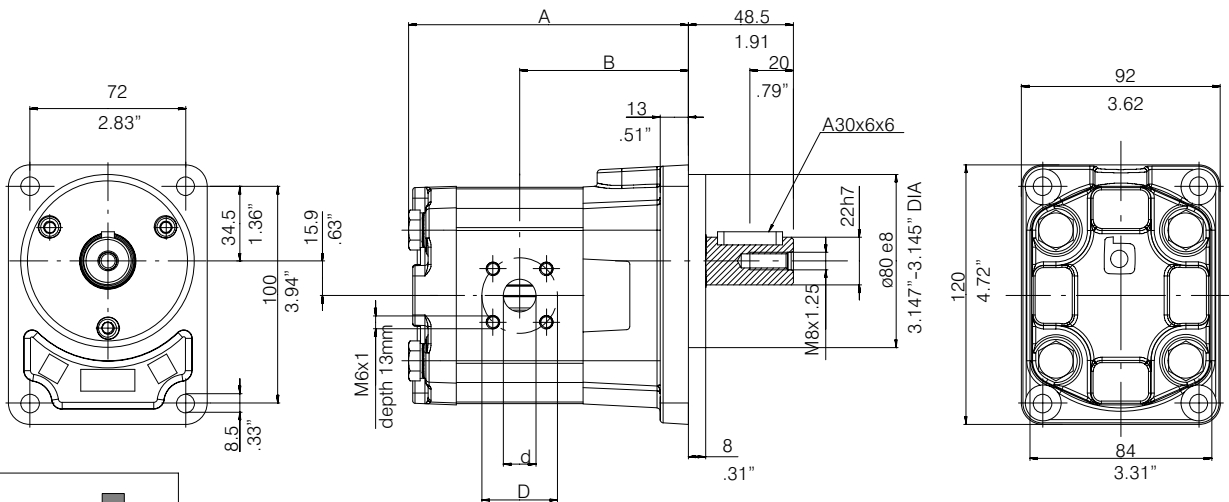

Max pressure (M max= 65 Nm)			
Motor	bar (PSI)		
	P1	P2	P3
APM200/15	180 (2600)	210 (3000)	230 (3300)
APM200/19	140 (2000)	165 (2400)	185 (2650)
APM200/22	120 (1700)	145 (2050)	165 (2350)
APM200/26	100 (1450)	120 (1750)	140 (2000)

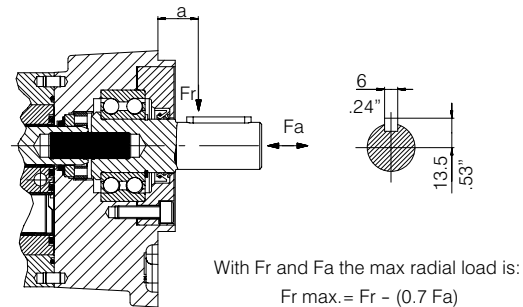
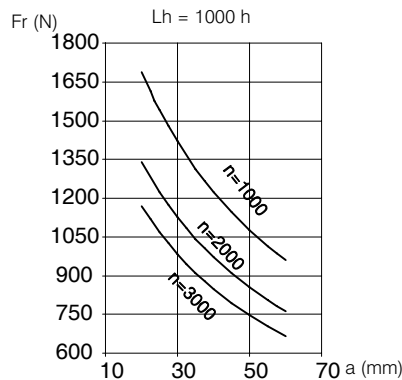

Type	Displacement cm <sup>3</sup> /rev	Dimensions				Outlet			Inlet						
		A		B		d	D		F	d	D		F		
		mm	inch	mm	inch	mm	inch	mm	mm	inch	mm	inch	mm		
<b>APM200/8.5</b>	8.3	113	4.45	70	2.75	15	.59	40	1.58	M6X1	15	.59	35	1.38	M6X1
<b>APM200/11</b>	10.95	129	5.08	78	3.06	20	.79								
<b>APM200/15</b>	14.95														
<b>APM200/19</b>	18.9	141	5.55	84	3.30										
<b>APM200/22</b>	21.9	145.5	5.73	86	3.39										
<b>APM200/26</b>	25.9														

Unidirectional motor

Type	Order Code	Clockwise rotation: D	Type	Order Code	Counterclockwise rotation: S
APM200/8.5 D			APM200/8.5 S		
APM200/11 D			APM200/11 S		
APM200/15 D			APM200/15 S		
APM200/19 D			APM200/19 S		
APM200/22 D			APM200/22 S		
APM200/26 D			APM200/26 S		

N.B.: With respect to the standards, the maximum pressures of some versions of this motor are reduced in relation to the max. torque allowed to the shaft.

Group **APMR200** Code **220 2T1**

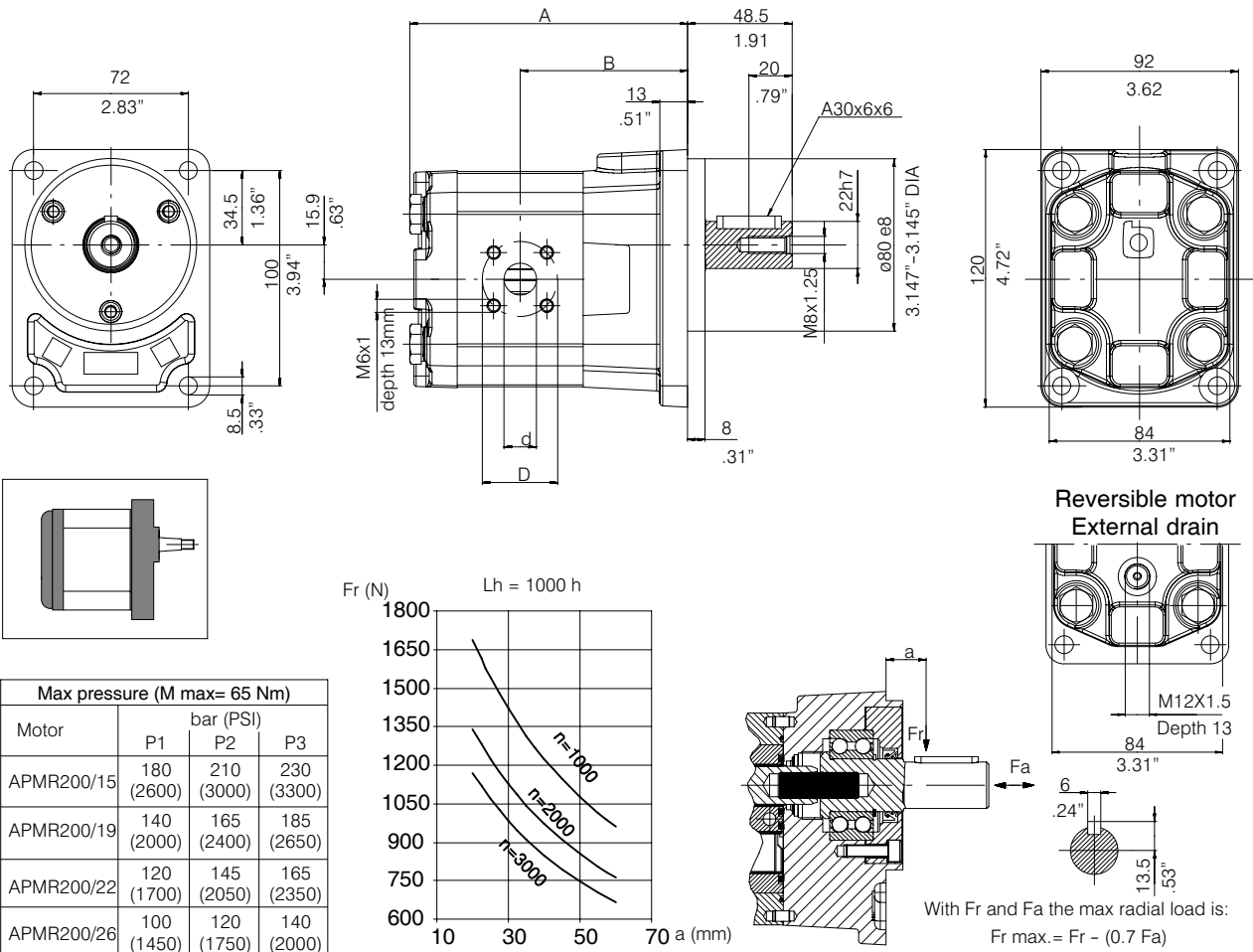

Type	Displacement cm <sup>3</sup> /rev	Dimensions				Outlet					Inlet				
		A		B		d		D		F	d		D	F	
		mm	inch	mm	inch	mm	inch	mm	inch	mm	mm	inch	mm	inch	mm
<b>APMR200/8.5</b>	8.3	113	4.45	70	2.75	15	.59	35	1.38	M6X1	15	.59	35	1.38	M6X1
<b>APMR200/11</b>	10.95	129	5.08	78	3.06										
<b>APMR200/15</b>	14.95														
<b>APMR200/19</b>	18.9	141	5.55	84	3.30										
<b>APMR200/22</b>	21.9	145.5	5.73	86	3.39										
<b>APMR200/26</b>	25.9														

Reversible motor

Type	Order Code	Reversible motor Internal drain	Type	Order Code	Reversible motor External drain
APMR200/8.5 ID			APMR200/8.5 ED		
APMR200/11 ID			APMR200/11 ED		
APMR200/15 ID			APMR200/15 ED		
APMR200/19 ID			APMR200/19 ED		
APMR200/22 ID			APMR200/22 ED		
APMR200/26 ID			APMR200/26 ED		

N.B.: With respect to the standards, the maximum pressures of some versions of this motor are reduced in relation to the max. torque allowed to the shaft.

Group **APFM200** Code **\*\*\***

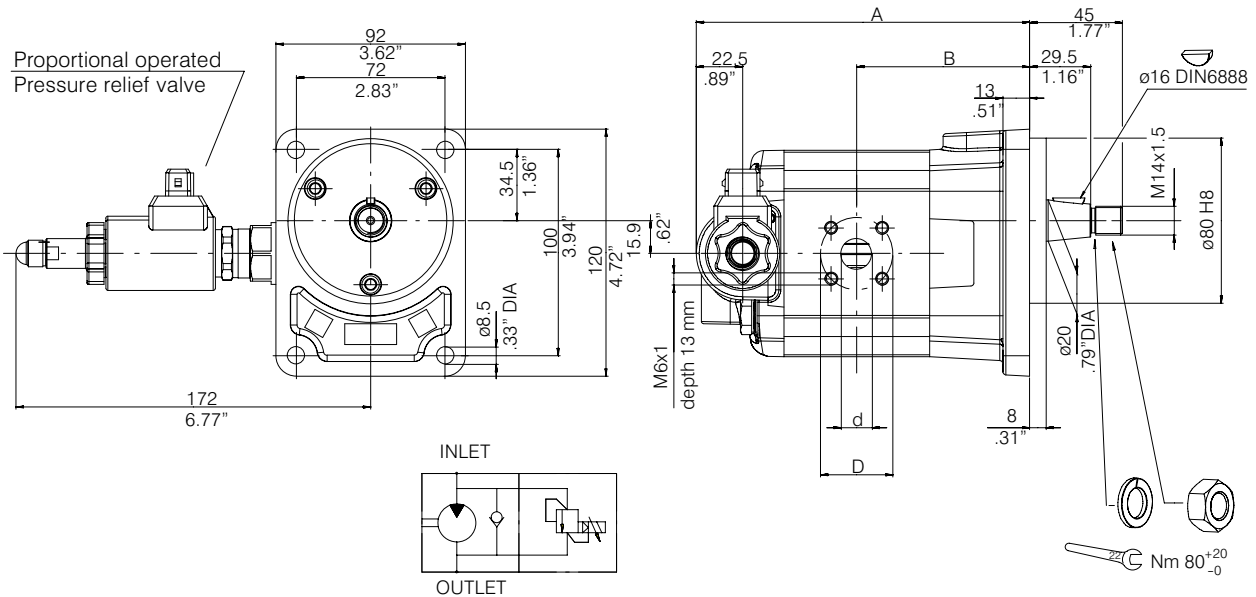

Max pressure (M max= 65 Nm)			
Motor	bar (PSI)		
	P1	P2	P3
APFM200/15	180 (2600)	210 (3000)	230 (3300)
APFM200/19	140 (2000)	165 (2400)	185 (2650)
APFM200/22	120 (1700)	145 (2050)	165 (2350)
APFM200/26	100 (1450)	120 (1750)	140 (2000)

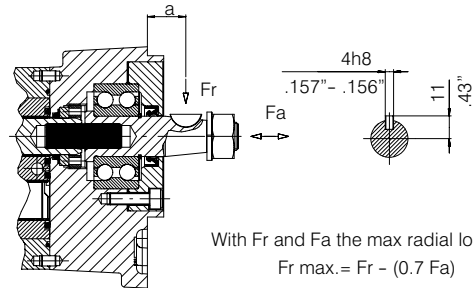
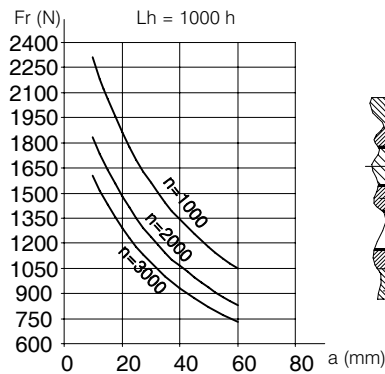

With Fr and Fa the max radial load is:  
Fr max. = Fr - (0.7 Fa)

Type	Displacement cm <sup>3</sup> /rev	Dimensions				Outlet			Inlet						
		A		B		d		D		F					
		mm	inch	mm	inch	mm	inch	mm	inch	mm	inch				
<b>APFM200/8.5</b>	8.3	70	2.76	134	5.28	15	.59	40	1.58	M6X1	15	.59	35	1.38	M6X1
<b>APFM200/11</b>	10.95	78	3.07	150	5.91	20	.79								
<b>APFM200/15</b>	14.95														
<b>APFM200/19</b>	18.9	84	3.31	162	6.38										
<b>APFM200/22</b>	21.9	86	3.39	166	6.33										
<b>APFM200/26</b>	25.9														

\*\*\* : For more and detailed information look at the specific catalogue: 100-P-000062-E "Hydraulic Drive System for Engine Cooling Fans".

Example of Fan Drive Motor ordering code

A P F M 2 0 0 / 1 5 D B 1 6 C 2 4 V K 2 C 0 N 0 0

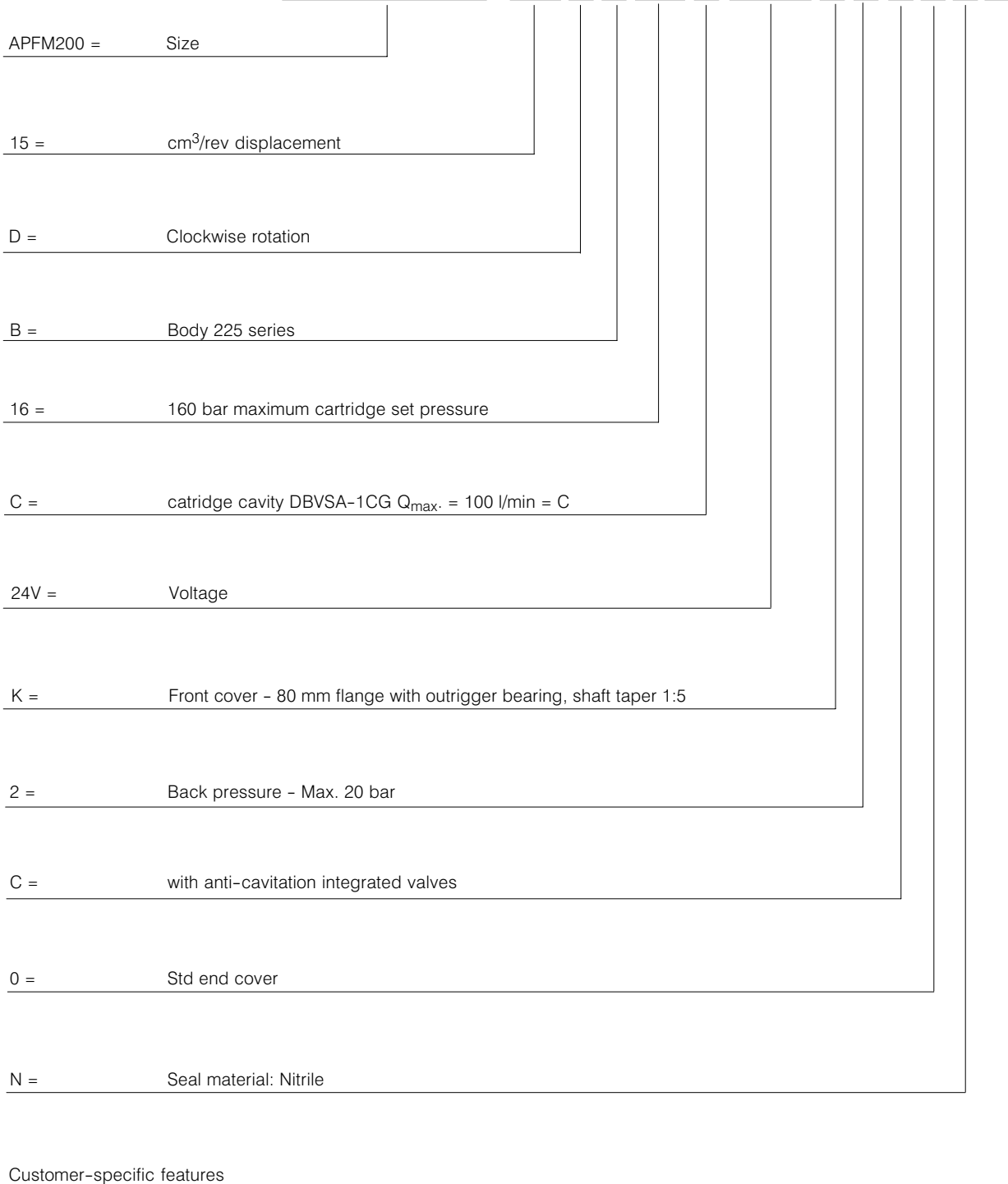

For more and detailed information look at the specific catalogue: 100-P-000062-E "Hydraulic Drive System for Engine Cooling Fans"

### Unidirectional motor APM200 with pressure relief valve VM

Unidirectional APM200 gear motor can be provided by a rear cover with a built in pressure relief valve **VM**. For the composition product code example see page 61/64.

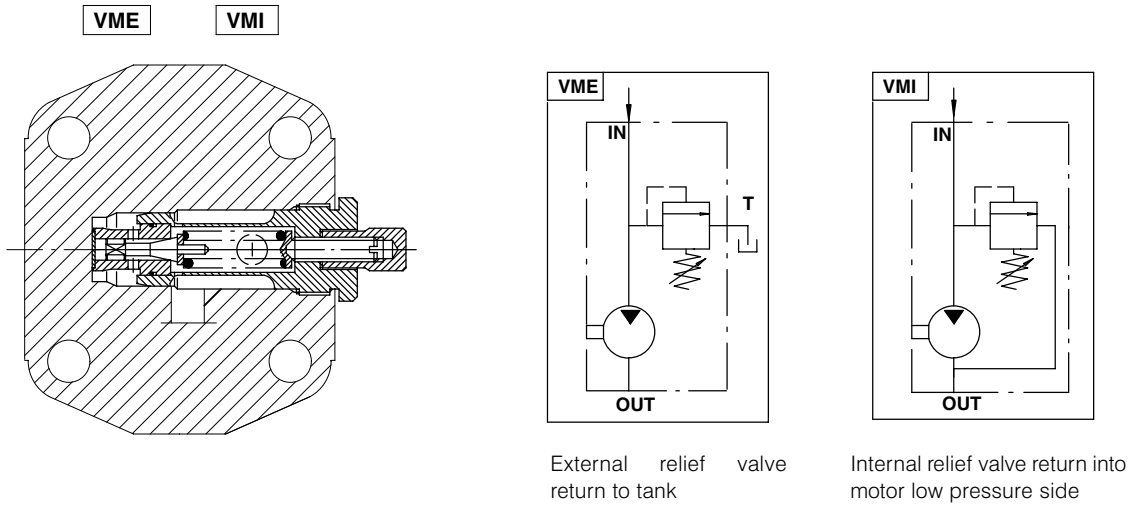

### Standard setting values for VM

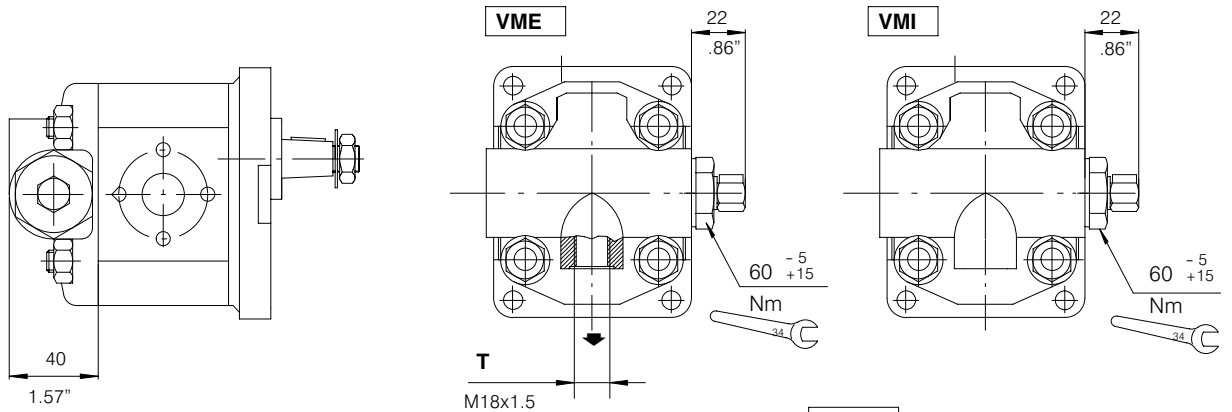

Note: all the above drawings are referred to counterclockwise rotation motors. For any other dimension look at the correspondent motor code.

Type	VME	06	15
	VMI	60	150
Bar	±10%	60	150

(spring **YE** with adjustment range 30÷80 bar)

(spring **GR** with adjustment range 70÷ 210 bar)

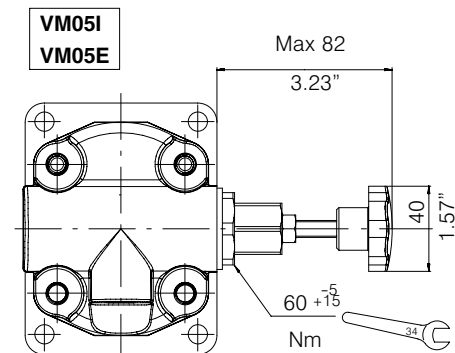

### Integrated anti-cavitation valves

APM200 gear motor can be equipped with integrated anti-cavitation valves. No change of external dimensions and any extra tank connection is required. Specify on motor code description adding + C. Ex: APM200/15 S 225 + C

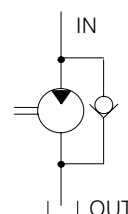

## 6 Accessories

### 6.1 Splined couplings

Material: UNI5331 16 CrNi4Pb Hardness 58 - 60 HRc (\*) UNI5332 38NiCrMo4Pb R= 950 - 1050 N/mm<sup>2</sup>

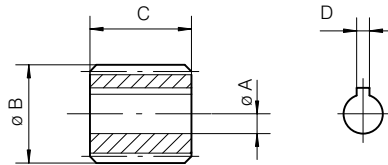

Type	Motor group	Order code	Spline profile DIN 5482	A		B		C		D		n. of feet
				mm	inch	mm	inch	mm	inch	mm	inch	
GSH-06	APM05	200.5314.20001	20X17	7	.27	19.5	.76	9	.35	2	.08	12

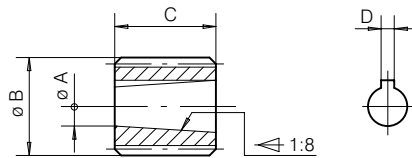

Type	Motor group	Order code	Spline profile DIN 5482	A		B		C		D		n. of feet
				mm	inch	mm	inch	mm	inch	mm	inch	
GSH-1-12	APM100	200.5315.30001	20X17	14.2	.56	19.5	.77	14.5	.57	2.4	.09	12
GSH-1-14	APM100	200.5315.30002	25x22			8	.31					24.5
GSH-2-14*	APM200	200.5315.40001	25x22			27.5	1.08	22	.87	3.2	.12	15
GSH-2-15	APM200	200.5315.40002	28x25			34.5	1.36					18
GSH-2-18	APM200	200.5315.40003	35x31									

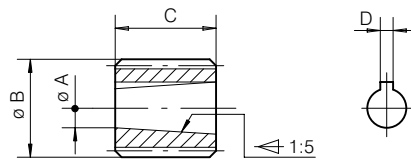

Type	Motor group	Order code	Spline profile DIN 5482	A		B		C		D		n. of feet
				mm	inch	mm	inch	mm	inch	mm	inch	
GSH-1B-12	APM100	200.5314.30001	20X17	7.6	.3	19.5	.77	12	.47	2	.08	12
GSH-2B-14*	APM200	200.5314.40001	25x22	13	.5	24.5	.96	20	.79	3	.12	14
GSH-2B-15	APM200	200.5314.40002	28x25			27.5	1.08					15
GSH-2B-18	APM200	200.5314.40003	35x31			34.5	1.36	18				

## 6.2 Motors seal kit NBR standard type

APM05	
Motor code	Seal kit
APM05/810	200.9740.0018.0
APM05/819	
APM05/310	
APM05/319	
APM05/830	
APM05/839	
APM05/330	
APM05/339	

APM100	
Motor code	Seal kit
APM100/218	200.9740.0031.0
APM100/219	
APM100/318	
APM100/319	
APM100/818	
APM100/845	
APM100/880	200.9740.0034.0
APM100/887S	
APM100/380	
APM100/387S	200.9740.0097.0
APM100/887S NPTF	
APM100/880 NPTF	200.9740.0098.0
APM100/2218	200.9740.0098.0
APM100/518	200.9740.0093.0

APM200/APMR200	
Motor code	Seal kit
APM200/218	200.9740.0073.0
APM200/818	
APM200/225	
APM200/227	
APM200/235	
APM200/245	
APM200/237	
APM200/247	
APM200/887S	
APM200/880	
APM200/887S NPTF	
APM200/880 NPTF	
APM200/287S-B	
APM200/280B	
APFM200	200.9740.0135.0
APM200/2K2	200.9740.0138.0
APM200/2T2	200.9740.0136.0
APM200/2K1	200.9740.0137.0
APMR200/2T1	200.9740.0134.0
APMR200/218	
APMR200/818	
APMR200/225	
APMR200/227	
APMR200/235	
APMR200/245	
APMR200/237	
APMR200/247	
APMR200/887S	
APMR200/880	
APMR200/887S NPTF	
APMR200/880 NPTF	
APMR200/287S-B	
APMR200/280B	

Note: For type of motors without ordering code, contact our Sales Department.

## 7 Composition of product code

### 7.1 Motor

Type	Rotation	Code
APM05/**	*	*****
APM100/**	*	*****
APM200/**	*	*****

Examples	Order code
APM05/0.75 D 310	200100460201
APM100/4,3 S 218	200101513601
APM200/26 D 287 S-B	200102886501

### 7.2 Motor with valve

Type	Rotation	Code	Valve
APM200/**	*	*****	*****
APM200/**	*	*****	*****
APM200/**	*	*****	*****
APM200/**	*	*****	*****

Examples	Order code
APM200/15 S 218 15VME	200102513605
APM200/6,5 S 218 15VMI	200102213606
APM200/8,5 D 218 12VRI	200102313504
APM200/6,5 D 235 + C	200102232501

### 7.3 Motor with bearing support

Type	Rotation	Code	Support
APM200/**	*	*****	*****
APM200/**	*	*****	*****

Examples	Order code
APM200/22 D 225 2K2+C	200102722508

## 7.4 Product identification plate

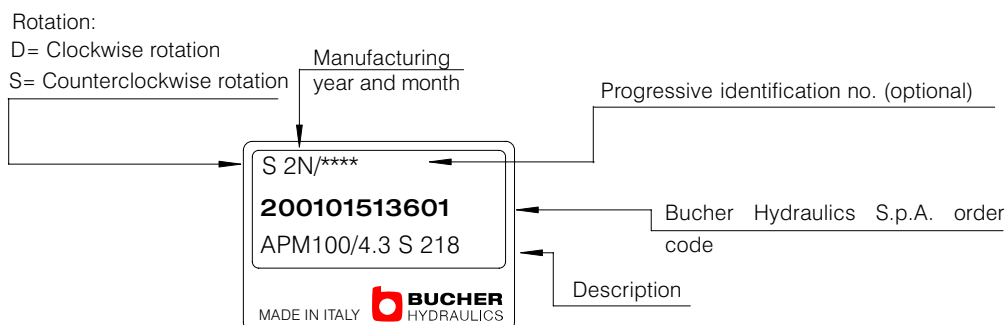

## 7.5 Motor weight

Motor	Weight Kg	Motor	Weight Kg	Motor	Weight Kg
APM05/0.5	0.45	APM100/2.5	1.03	APM200/8.5	1.95
APM05/0.75	0.45	APM100/3.5	1.07	APM200/11	2.33
APM05/0.9	0.48	APM100/4.3	1.12	APM200/15	2.34
APM05/1.2	0.50	APM100/5	1.18	APM200/19	2.65
APM05/1.6	0.50	APM100/6.5	1.23	APM200/22	2.78
APM05/2.3	0.55	APM100/8	1.28	APM200/26	2.82
		APM100/10	1.35		

N.B.: The weight refers to motors with version code 810 (APM05) – 218 (APM100 – APM200). Limited weight variations are possible for motors having a different code.

Manufacturing month	Manufacturing year											
	2002	2003	2004	2005	2006	2007	2008	2009	2010	2011	2012	
January	2M	3M	4M	5M	6M	7M	8A	9A	0A	1A	2A	
February	2N	3N	4N	5N	6N	7N	8B	9B	0B	1B	2B	
March	2P	3P	4P	5P	6P	7P	8C	9C	0C	1C	2C	
April	2Q	3Q	4Q	5Q	6Q	7Q	8D	9D	0D	1D	2D	
May	2R	3R	4R	5R	6R	7R	8E	9E	0E	1E	2E	
June	2S	3S	4S	5S	6S	7S	8F	9F	0F	1F	2F	
July	2T	3T	4T	5T	6T	7T	8G	9G	0G	1G	2G	
August	2U	3U	4U	5U	6U	7U	8H	9H	0H	1H	2H	
September	2V	3V	4V	5V	6V	7V	8I	9I	0	1I	2I	
October	2Z	3Z	4Z	5Z	6Z	7Z	8J	9J	0J	1J	2J	
November	2X	3X	4X	5X	6X	7X	8K	9K	0K	1K	2K	
December	2Y	3Y	4Y	5Y	6Y	7Y	8L	9L	0L	1L	2L	



**[info.it@bucherhydraulics.com](mailto:info.it@bucherhydraulics.com)**

**[www.bucherhydraulics.com](http://www.bucherhydraulics.com)**

© 2008 by Bucher Hydraulics S.p.A., IT - 42100 Reggio Emilia.

All rights reserved.

Data is provided for the purpose of product description only, and must not be considered as warranted characteristics in the legal sense. The information does not relieve users from the duty of conducting their own evaluations and tests. Because the products are subject to continual improvement, we reserve the right to amend the product specifications contained in this catalogue.