

TU 55 TF

Take-up cast iron unit with insert ball bearing, set screw locking and extended inner ring, ISO

Take-up ball bearing units, consisting of an insert bearing based on a sealed deep groove ball bearing mounted in a grey cast iron housing. Typically mounted in take-up frames, the unit has an inner ring extended on both sides and is locked by tightening a set screw on the inner ring, which makes it easy to mount.

- Designed for an alternating rotation
- Quick and easy to mount onto the shaft
- Accommodate static initial misalignment
- Long service life
- Reduced noise and vibration levels



Overview

Dimensions

Bearing width, total	55.6 mm
Housing overall width	64 mm
Shaft diameter	55 mm

Performance

Basic dynamic load rating	43.6 kN
Basic static load rating	29 kN
Limiting speed	3 600 r/min

Note: Limiting speed with shaft tolerance h6

Properties

Bore type	Cylindrical
Coating	Without
Grease fitting	With
Housing type	Take-up
Lubricant	Grease
Material, bearing	Bearing steel
Material, housing	Cast iron
Relubrication hole	With
Retaining feature, inner ring	Set screws
Rubber seating ring	Without
Sealing type	Contact, standard
Sealing, bearing	Seal and flinger on both sides

Sealing, unit

Optional end cover

Technical Specification

Compliance with standard	ISO
Purpose specific	For material handling applications
Material, housing	Cast iron
Sealing, bearing	Seal and flinger on both sides
Sealing type, bearing	Contact, standard
Sealing, unit	Optional end cover
Coating	Without

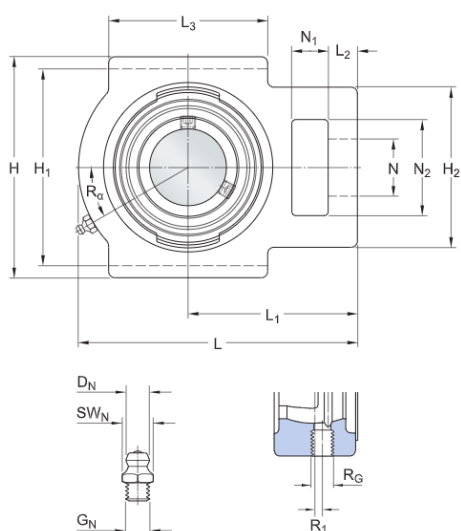
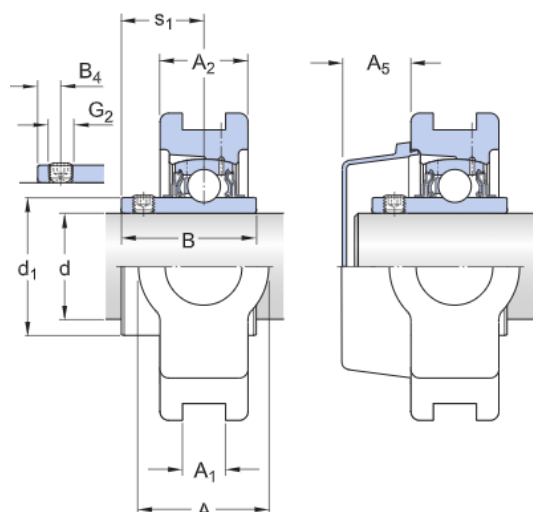

Dimensions

d	55 mm	Bore diameter
d_1	≈ 69.06 mm	Shoulder diameter inner ring
A	64 mm	Overall width
A_1	27 mm	Width of piloting groove
A_2	41 mm	Width of flange in which piloting grooves are provided
A_5	33.5 mm	Standout of end cover
B	55.6 mm	Width of inner ring
B_1	55.6 mm	Overall bearing width
B_4	9 mm	Distance from locking device side face to thread centre
H	146 mm	Overall height
H_1	130 mm	Distance between bottoms of piloting grooves
H_2	102 mm	Height of attachment end
L	171 mm	Overall length

	mm	
L_1	106 mm	Distance from attachment end face to centre line of spherical seat diameter
L_2	19 mm	Length attachment end
L_3	95 mm	Length of piloting groove
N	35 mm	Diameter of attachment bolt hole
N_1	25 mm	Length of attachment slot
N_2	64 mm	Height of attachment slot
s_1	33.4 mm	Distance from locking device side face to raceway centre

Threaded hole

R_C	1/4-28 UNF	Housing thread for the grease fitting
R_1	5 mm	Axial position of the housing thread
R_0	30 °	Angular position of the housing thread

Grease fitting

D_f	6.5 mm	Diameter of head sphere of grease fitting
S_f	7 mm	Hexagonal key size for the grease fitting
G_f	1/4-28 SAE-LT	Thread of grease fitting

Calculation data

Basic dynamic load rating	C	43.6 kN
Basic static load rating	C_0	29 kN
Fatigue load limit	P_u	1.25 kN
Limiting speed		3 600 r/min
with shaft tolerance h6		

Mass

Mass bearing unit	3.9 kg
-------------------	--------

Mounting information

Set screw	G ₂	M10x1
Hexagonal key size for set screw		5 mm
Recommended tightening torque for set screw		16.5 Nm

Included products

Housing	TU 511 M
Bearing	YAR 211-2F

Associated products

End cover	ECY 211
-----------	---------

Terms and conditions

By accessing and using this website / app owned and published by AB SKF (publ.) (556007-3495 · Gothenburg) ("SKF"), you agree to the following terms and conditions:

Warranty Disclaimer and Limitation of Liability

Although every care has been taken to assure the accuracy of the information on this website / app, SKF provides this information "AS IS" and DISCLAIMS ALL WARRANTIES, EXPRESS OR IMPLIED, INCLUDING, BUT NOT LIMITED TO, IMPLIED WARRANTIES OF MERCHANTABILITY AND FITNESS FOR A PARTICULAR PURPOSE. You acknowledge that your use of this website / app is at your sole risk, that you assume full responsibility for all costs associated with use of this website / app, and that SKF shall not be liable for any direct, incidental, consequential, or indirect damages of any kind arising out of your access to, or use of the information or software made available on this website / app. Any warranties and representations in this website / app for SKF products or services that you purchase or use will be subject to the agreed upon terms and conditions in the contract for such product or service. Further, for non-SKF websites / apps that are referenced in our website / app or where a hyperlink appears, SKF makes no warranties concerning the accuracy or reliability of the information in these websites / apps and assumes no responsibility for material created or published by third parties contained therein. In addition, SKF does not warrant that this website / app or these other linked websites / apps are free from viruses or other harmful elements.

Copyright

Copyright in this website / app copyright of the information and software made available on this website / app rest with SKF or its licensors. All rights are reserved. All licensed material will reference the licensor that has granted SKF the right to use the material. The information and software made available on this website / app may not be reproduced, duplicated, copied, transferred, distributed, stored, modified, downloaded or otherwise exploited for any commercial use without the prior written approval of SKF. However, it may be reproduced, stored and downloaded for use by individuals without prior written approval of SKF. Under no circumstances may this information or software be supplied to third parties.

This website /app includes certain images used under license from Shutterstock, Inc.

Trademarks and Patents

All trademarks, brand names, and corporate logos displayed on the website / app are the property of SKF or its licensors, and may not be used in any way without prior written approval by SKF. All licensed trademarks published on this website / app reference the licensor that has granted SKF the right to use the trademark. Access to this website / app does not grant to the user any license under any patents owned by or licensed to SKF.

Changes

SKF reserves the right to make changes or additions to this website / app at any time.