

ENGINEERING
TOMORROW

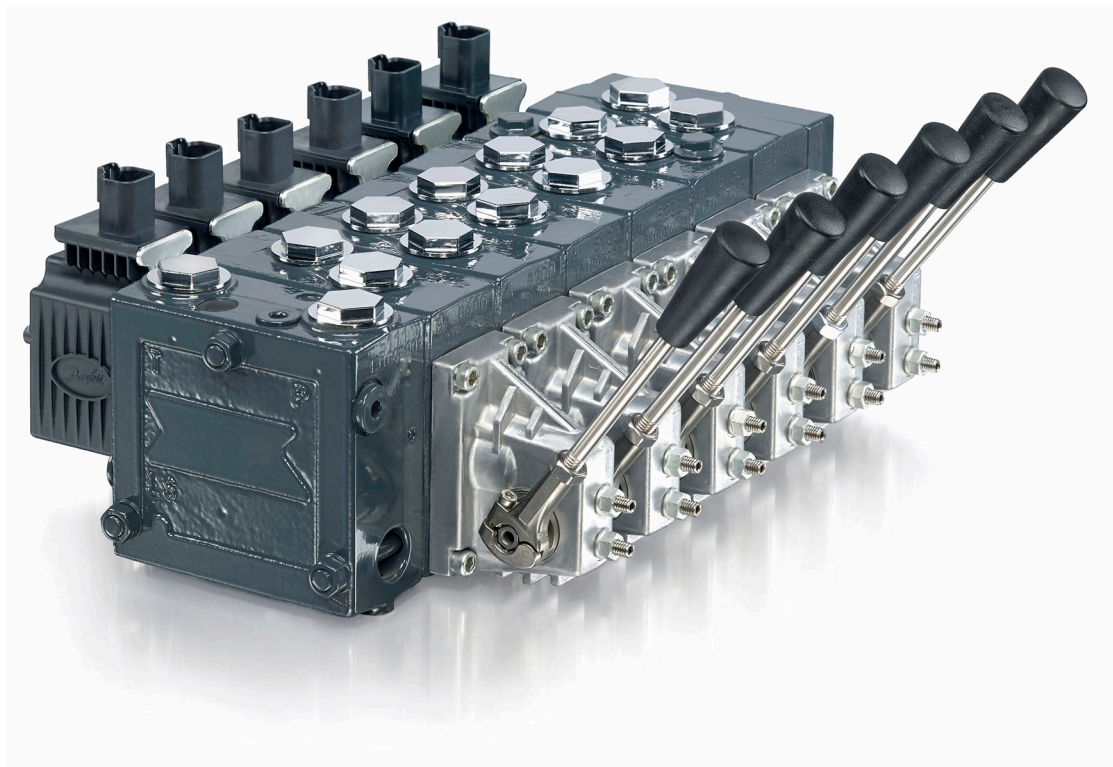

Service Manual

PVG 32



Revision history*Table of revisions*

Date	Changed	Rev
February 2017	Updated with PVE Series 7	0301
May 2014	Converted to Danfoss layout – DITA CMS	BA
Feb 2006 - Aug 2013	Various changes	AB - BA

Contents

Introduction

Overview.....	5
General instructions.....	5
Remove the unit.....	5
Keep it clean.....	5
Replace all O-rings and gaskets.....	5
Secure the unit.....	5
Safety precautions.....	6
Unintended machine movement.....	6
Flammable cleaning solvents.....	6
Fluid under pressure.....	6
Personal safety.....	6
Hazardous material.....	6
Acronyms.....	6

Operation

PVG 32 group with open center PVP (PVB with flow control spool).....	8
PVG 32 group with closed center PVP (PVB with flow control spool).....	8
PVG 32 sectional drawing.....	9
PVPC plug for external pilot oil supply.....	9
Friction detent.....	11
PVBS, main spools for flow control (standard).....	12
PVBS, main spools for flow control (with linear characteristics).....	12
PVBS, main spools for pressure control.....	12
PVPX Electrical LS unloading valve.....	13

System Troubleshooting

Overview.....	14
Troubleshooting a PVG valve.....	14
No cylinder/motor response in either direction when remote controller is actuated.....	15
Cylinder/motor responds in one direction only.....	16
Main valve spool moves without oil passing to cylinder/motor.....	16
Cylinder/motor operates without remote controller being operated.....	17
Cylinder/motor responds slowly to remote electrical or hydraulic controller actuation.....	17
Erratic cylinder/motor response to electrical or hydraulic controller operation.....	17
Hydraulic oil supply.....	18
Electrical supply.....	18
Hydraulic (remote) pilot control pressure.....	19

PVG 32 Component Troubleshooting

Pressure relief valve.....	20
Pressure reducing pilot valve.....	20
Pressure gauge connection.....	21
Open center plug.....	22
Closed center plug and orifice.....	23
Pressure adjustment spool.....	24
LS connection.....	25
LS signal.....	25
Shuttle valve.....	26
LS pressure limiting valve.....	27
LS A, B shuttle.....	27
Main spool.....	28
Shock and anti-cavitation valve PVLV.....	29
Pressure compensator.....	30
Load drop check valve.....	31
Maximum oil flow adjustment screws for ports A and B.....	32
PVM module.....	33
PVS module.....	34
PVPVM module.....	35
PVAS module.....	36
PVPX LS unloading valve.....	37

Contents

PVEM, PVEA, PVEH, PVES electrical actuators.....	38
Troubleshooting Considerations.....	38
PVEO ON/OFF electrical actuator.....	39
PVPC plug for external pilot control.....	42
PVMR Friction Module.....	42

Introduction

Overview

This manual includes information for servicing PVG 32 valves. It includes a description of the units and their individual components, troubleshooting information, and minor repair procedures.

Performing minor repairs may require removal from the vehicle/machine. Thoroughly clean the unit before beginning maintenance or repair activities. Since dirt and contamination are the greatest enemies of any type of hydraulic equipment, follow cleanliness requirements strictly. This is especially important when changing the system filter and when removing hoses or plumbing.

A worldwide network of Danfoss Global Service Partners is available for major repairs. Danfoss trains and certifies Global Service Partners on a regular basis. You can locate your nearest Global Service Partner using the distributor locator at www.Danfoss.com.

For specifications and operating parameters on PVG 32 valves, refer to PVG 32 Technical Information Manual **520L0344**.

[Do not attempt to service PVG valves without build sheet specifications for reference.](#)

General instructions

Follow these general procedures when repairing PVG 32 valves.

Remove the unit



Chock the wheels on the vehicle or lock the mechanism to inhibit movement. Prior to performing repairs, remove the unit from the vehicle/machine. Be aware that hydraulic fluid may be under high pressure and/or hot. Inspect the outside of the valve stack and fittings for damage. Cap hoses after removal to prevent contamination.

Keep it clean



Cleanliness is a primary means of assuring satisfactory motor life, on either new or repaired units. Clean the outside of the valve thoroughly before disassembly. Take care to avoid contamination of the port connections on the valve stack. Clean parts using a clean solvent wash and air dry.

As with any precision equipment, keep all parts free of foreign materials and chemicals. Protect all exposed sealing surfaces and open cavities from damage and foreign material. If left unattended, cover the valve with a protective layer of plastic.

Replace all O-rings and gaskets



Danfoss recommends you replace all O-rings. Lightly lubricate all O-rings with clean petroleum jelly prior to assembly.

Secure the unit



For repair, place the unit in a stable position with the shaft pointing downward. Secure the motor while removing and torquing controls, and valves.

Introduction

Safety precautions

Always consider safety precautions before beginning a service procedure. Protect yourself and others from injury. Take the following general precautions whenever servicing a hydraulic system.

Unintended machine movement

Warning

Unintended movement of the machine or mechanism may cause injury to the technician or bystanders. To protect against unintended movement, secure the machine or disable/disconnect the mechanism while servicing.

Flammable cleaning solvents

Warning

Some cleaning solvents are flammable. To avoid possible fire, do not use cleaning solvents in an area where a source of ignition may be present.

Fluid under pressure

Warning

Escaping hydraulic fluid under pressure can have sufficient force to penetrate your skin causing serious injury and/or infection. This fluid may also be hot enough to cause burns. Use caution when dealing with hydraulic fluid under pressure. Relieve pressure in the system before removing hoses, fittings, gauges, or components. Never use your hand or any other body part to check for leaks in a pressurized line. Seek medical attention immediately if you are cut by hydraulic fluid.

Personal safety

Warning

Protect yourself from injury. Use proper safety equipment, including safety glasses, at all times.

Hazardous material

Warning

Hydraulic fluid contains hazardous material. Avoid prolonged contact with hydraulic fluid. Always dispose of used hydraulic fluid according to state and federal environmental regulations.

Acronyms

This table provides a definition of commonly used terms.

P = Proportional V = Valve	
PVP	Pump side module
PVPV/M	Pump side module
PVB	Basic module
PVLA	Anti-cavitation valve
PVLP	Shock and anti-cavitation valve
PVS/PVSI	End plate
PVAS (PVP, PVPV/M)	Assembly kit for PVP, PVPV/M

Introduction

PVPX, LS	LS Unloading valve
PVPC	Plug for external pilot oil supply
PVBS	Main spool
PVM	Mechanical activation
PVMD	Cover for mechanical activation
PVH	Cover for hydraulic activation
PVMF	Cover for mechanical float
PVMR	Cover for friction detent PVMR or float position
PVEH, PVES, PVEA	Electrical activation
PVEM	Electrical activation
PVEO	Electrical activation

Operation

PVG 32 group with open center PVP (PVB with flow control spool)

When the pump starts, and the main spools in the individual basic modules (11) are in the neutral position, oil flows from the pump, through connection P, across the pressure adjustment spool (6) to tank. The oil flow led across the pressure adjustment spool determines the pump pressure (stand-by pressure).

When one or more of the main spools actuate, the highest load pressure is fed through the shuttle valve circuit (10) to the spring chamber behind the pressure adjustment spool (6), and completely or partially closes the connection to tank.

Pump applies pressure to the right-hand side of the pressure adjustment spool (6). The pressure relief valve (1) opens if the load pressure exceeds the set value, diverting pump flow back to tank.

In a pressure-compensated basic module the compensator (14) maintains a constant

Pressure drop across the main spool—both when the load changes and when a module with a higher load pressure is actuated.

With a non pressure-compensated basic module incorporating a load drop check valve (18) in channel P, the check valve prevents return oil flow. The basic module can have the load drop check valve in channel P for functions with over-center valves.

The shock valves PVLP (13) with fixed setting and the suction valves PVLA (17) on ports A and B are used for the protection of the individual working function against overload and/or cavitation.

An adjustable Load Sensing (LS) pressure limiting valve (12) can be built into the A and B ports of pressure-compensated basic modules to limit the pressure from the individual working functions.

The LS pressure limiting valves save energy compared to the shock valves PVLP. With PVLP all the oil flow to the working function flows across the combined shock and suction valves to tank if the pressure exceeds the fixed setting. With LS pressure limiting valves, an oil flow of about 2 l/min [0.5 US gal/min] flows across the LS pressure limiting valve to tank if the pressure exceeds the valve setting.

PVG 32 group with closed center PVP (PVB with flow control spool)

In the closed center version, an orifice (5) and a plug (7) are fitted instead of the plug (4). This means that the pressure adjustment spool (6) only opens to tank when the pressure in channel P exceeds the set value of the pressure relief valve (1).

In LS systems, the load pressure flows to the pump regulator via the LS connection (8).

In the neutral position the pump control sets the displacement so that leakage in the system is compensated to maintain the set stand-by pressure. When a main spool is actuated, the pump regulator adjusts the displacement to maintain the set differential pressure between P and LS.

The pressure relief valve (1) in PVP should be set at a pressure of approximately 30 bar [435 psi] above maximum system pressure (set on the pump or external pressure relief valve).

Operation

PVG 32 sectional drawing

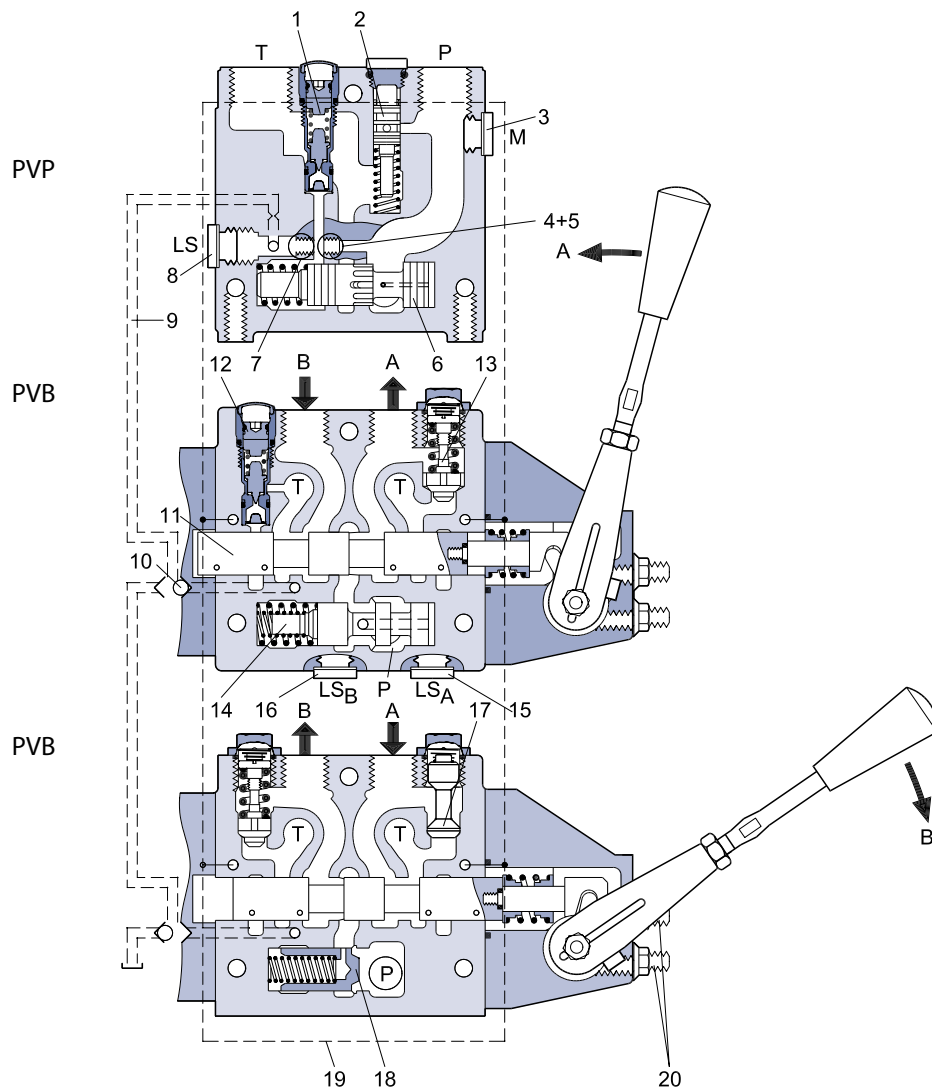

157-104.11

- | | |
|--|--|
| <ul style="list-style-type: none"> 1. Pressure relief valve 2. Pressure reduction valve for pilot oil supply 3. Pressure gauge connection 4. Plug, open centre 5. Orifice, closed centre 6. Pressure adjustment spool 7. Plug, closed centre 8. LS connection 9. LS signal 10. Shuttle valve | <ul style="list-style-type: none"> 11. Main spool 12. LS pressure limiting valve 13. Shock and suction valve, PVL P 14. Pressure compensator 15. LS connection, port A 16. LS connection, port B 17. Suction valve, PVL A 18. Load drop check valve 19. Pilot oil supply for PVE 20. Max. oil flow adjustment screws for ports A and B |
|--|--|

PVPC plug for external pilot oil supply

PVPC with check valve for open center PVP

PVPC, with check valve, is used in systems where it is necessary to operate the PVG 32 valve by means of the electrical remote control without pump flow. When the external solenoid valve is opened, oil from

Operation

the pressure side of the cylinder is fed via the PVPC through the pressure reducing valve to act as the pilot supply for the electrical actuators.

This means that a load can be lowered by means of the remote control lever without starting the pump. The built-in check valve prevents the oil from flowing via the pressure adjustment spool to tank.

With the pump functioning normally, the external solenoid valve is closed to ensure that the load is not lowered due to the pilot supply oil flow requirement of approximately 1 l/min [0.26 US gal/min].

With closed center PVP, the external pilot oil supply can be connected to the pressure gauge connection without the use of a PVPC plug.

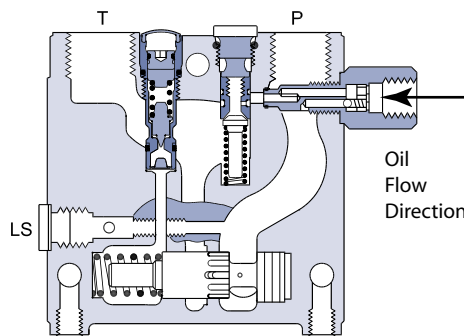

157-114.11

PVPC without check valve for open center PVP

PVPC, without check valve, is used in systems where it is necessary to supply the PVG 32 valve with oil from a manually operated emergency pump without directing oil flow to the pilot oil supply (oil consumption about 1 l/min) [0.25 US gal/min].

When the main pump is working normally, the oil is directed through the PVPC plug through the pressure reduction valve to the electrical actuators.

When the main pump flow fails, the external shuttle valve ensures that the oil flow from the manually operated emergency pump is used to pilot open the over center valve and lower the load. The load can only be lowered using the mechanical operating lever of the PVG 32 valve.

With closed center PVP, the external pilot oil supply can be connected to the pressure gauge connection without the use of a PVPC plug.

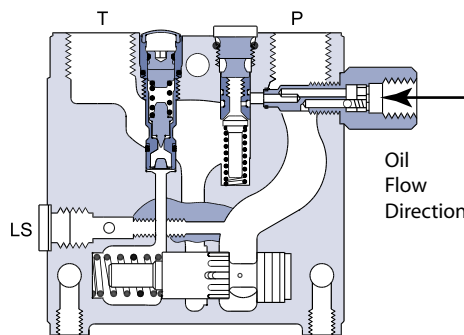

157-114.11

For specifications on PVG 32 valves, refer to PVG 32 Technical Information Manual **520L0344**.

Operation

Friction detent

PVMR Friction detent

The friction detent PVMR allows the directional spool to be held in any position, resulting in infinitely variable, pressure compensated flow. The spool position will be held indefinitely without the necessity of holding the mechanical lever.

PVMR should only be used together with PVB basic modules with pressure compensator.

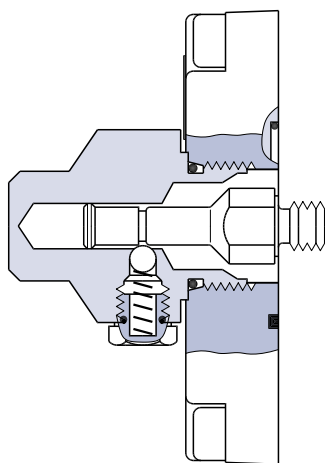

157-204.10

PVMF Mechanical float position lock

This allows the float spool to be held in the float position after release of the mechanical handle.

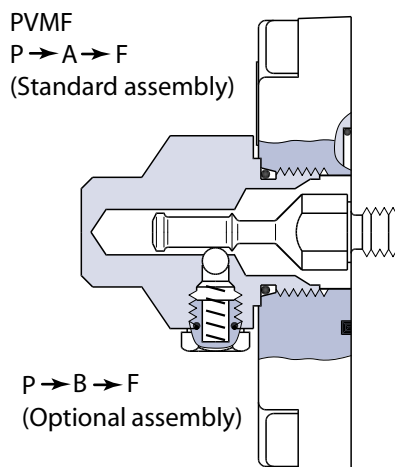

157-205.10

Operation

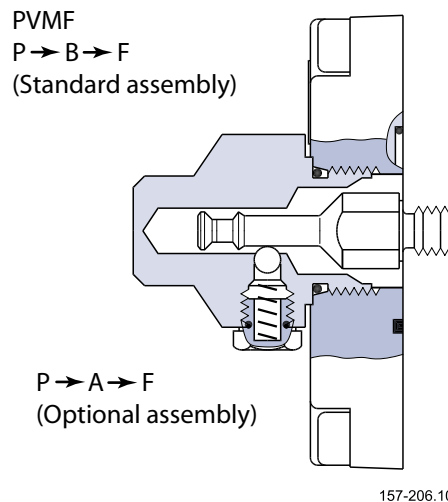

PVBS, main spools for flow control (standard)

When using standard flow control spools, the pump pressure is determined by the highest load pressure. This is done either via the pressure adjustment spool in open center PVP (fixed displacement pumps) or via the pump regulator (variable displacement pumps).

In this way the pump pressure will always correspond to the load pressure plus the stand-by pressure of the pressure adjustment spool or the pump regulator.

This will normally give optimum and stable adjustment of the oil flow.

PVBS, main spools for flow control (with linear characteristics)

PVBS main spools with linear characteristic have less dead band than standard spools and a completely proportional ratio between control signal and oil flow in the range beyond the dead band.

⚠ Warning

PVBS with linear characteristic must never be used together with PVEM electrical actuators.

The interaction between the small dead band of the spools and the hysteresis of the PVEM actuator of 20% involves a risk of building up a LS pressure in neutral position.

PVBS, main spools for pressure control

In a few systems load sensing pump pressure may result in unstable adjustment of the oil flow and a tendency towards system hunting. This may be the case with working functions that have a large moment of inertia or over-center valves. In such systems main spools for pressure control can be advantageous. The spools are designed in such a way that the pump pressure is controlled by the spool travel. The main spool must be displaced until the pump pressure just exceeds the load pressure before the working function is applied.

If the main spool is held in this position, the pump pressure will remain constant – even if the load pressure changes – giving a stable system.

The use of pressure control spools, however, also means that:

- the oil flow is load dependent
- the dead band is load dependent
- the pump pressure can exceed the load pressure by more than is usual.

Operation

Due to these factors use pressure control spools only when you know for certain that problems with stability will arise – or already have arisen.

Use LS_{A/B} when pressure stability is an issue.

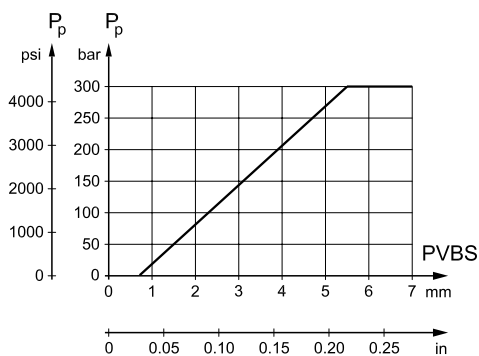

157-156.10

PVPX Electrical LS unloading valve

PVPX is a solenoid LS unloading valve. PVPX is fitted into the pump side module enabling a connection to be made between the LS and the tank lines. Thus the LS signal can be relieved to tank by means of an electric signal.

For a PVP pump side module in open center version the relief to tank of the LS signal means that the pressure in the system is reduced to the sum of the tank port pressure plus the neutral flow pressure for the pump side module.

For a PVP pump side module in closed center version, relief to tank of the LS signal occurs when the pressure is reduced by the sum of the tank port pressure for the pump side module plus the stand-by pressure of the pump.

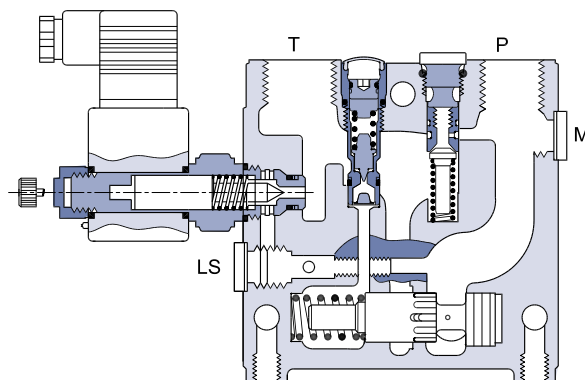

157-195.11

⚠ Caution

Protect yourself from injury. Use proper safety equipment, including safety glasses, at all times.

System Troubleshooting

Overview

Warning

This troubleshooting guide for the PVG valve assemblies does not cover valves that have been altered from original valve build specifications

This section provides general steps to follow if undesirable system conditions are observed. Follow the steps listed until the problem is solved. Some of the items will be system specific. Always observe the safety precautions listed in the [Introduction](#) section, and related to your specific equipment.

Confirm that valve is built properly according to the specification sheet.

If necessary, install a lever to the valve to verify proper mechanical function.

Refer to PVG 32 Technical Information Manual **520L0344** for valve configuration information.

Refer to PVG 32 Parts Manual **11006794** for part numbers.

Troubleshooting a PVG valve

THINK - before troubleshooting a problem.

Every fault location process should follow a logical and systematic order.

It is wisest to start at the beginning:

- Is the oil level correct when the pump is operating?
- Is the condition of oil and filters acceptable?
- Are pressure, flow, and flow direction as specified?
- Is the oil temperature too high or too low (oil viscosity)?
- Are there any unusual vibrations or noise (cavitation)?

If the driver of the vehicle is available, ask him:

- What type of fault it is and how it affects the system?
- How long he has he felt that something has been wrong?
- If he has "fiddled" with the components?
- If he has any hydraulic and electrical diagrams available?

Diagrams are often found in the instructions included with vehicles/machines.

Unfortunately they are often so technical that they are not of much use in a fault location situation. However; the diagram usually shows the order of, and the connections between, the individual components.

When a defective component is identified, clean the component and its surroundings before removal.

Remove loose paint from pipes and fittings.

Cover all holes, hoses and pipe ends with plugs or seal with, for example, plastic bags after removal to avoid the entry of dirt during repairs.

Never disassemble hydraulic components outside.

Perform repairs in a workshop on a clean workbench (covered with clean cloth or newspaper).

Make sure that a Danfoss service manual for with the product is handy.

Follow the instructions word for word during disassembly and assembly.

If these instructions are not followed closely the system may not operate correctly after repairs are completed.

Note that in some cases special tools are necessary for assembling the product.

Our service manuals give full guidance on use of special tools.

System Troubleshooting

Troubleshooting flow chart

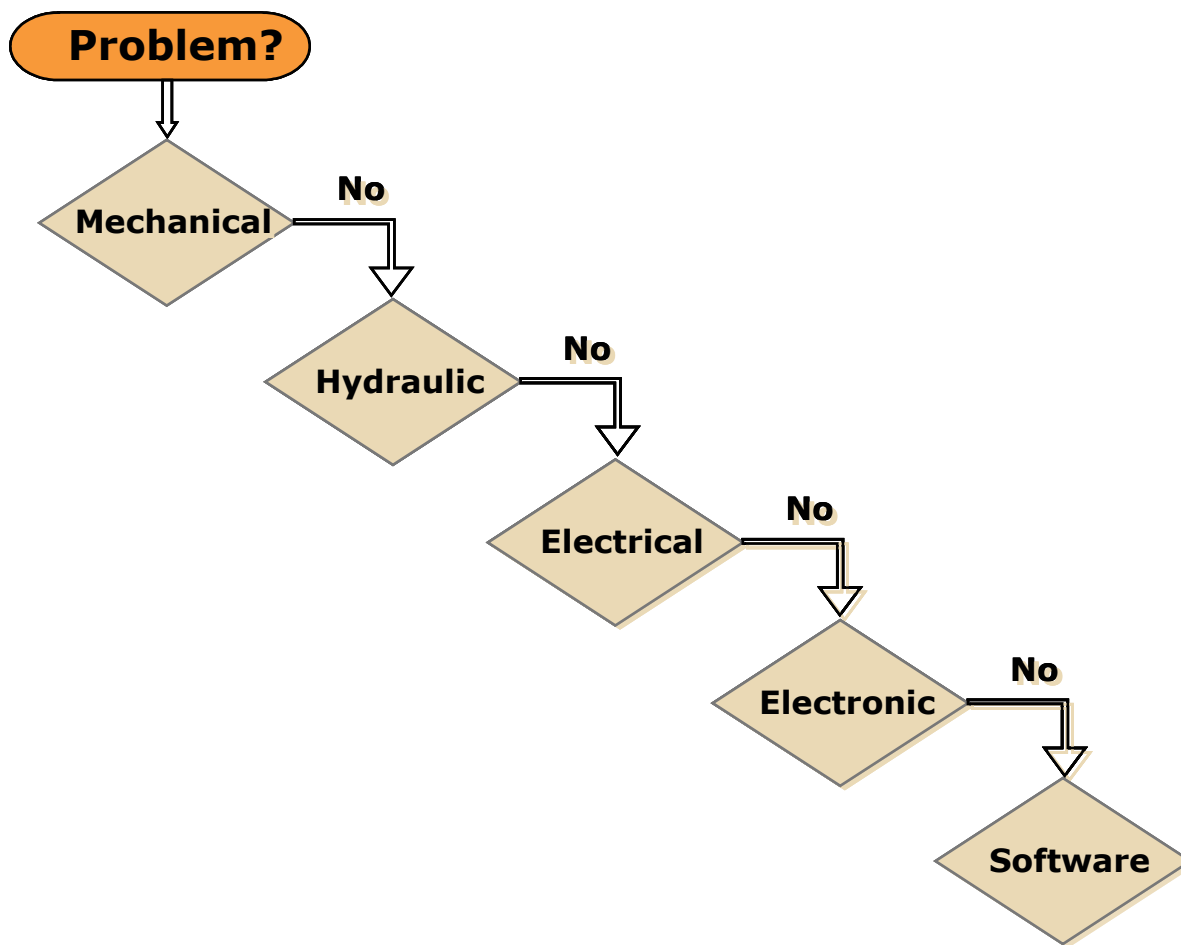

P107 823

No cylinder/motor response in either direction when remote controller is actuated

Cause	Check	Corrective action
Verify if fault is mechanical, electrical or hydraulic	Operate manual lever to confirm mechanical or electrical or hydraulic	If moving the manual lever operates the cylinder/motor check electrical or hydraulic
Sticking main spool	Remove manual, electrical, and hydraulic actuators from the valve section. Remove main spool from valve section and inspected for damage. If no damage reinstall the main valve spool and it should move freely in the valve section bore.	Replace the valve module and main spool. If any damage is found on the main spool
	Check movement of manual lever when electrical controller is operated	If manual lever does not move check electrical voltage signal from controller, wiring at the PVE module
	Check movement of manual lever when hydraulic controller is operated	If manual lever does not move check hydraulic controller pressure at the PVG valve module - 25 Bar [360 PSI]
	If none of the above check pump per manufacturers recommended procedure	Repair or replace pump per manufacturers recommended procedure
Internal filters blocked	Check for blockage in internal filters	Remove blockage

System Troubleshooting
Cylinder/motor responds in one direction only

Cause	Check	Corrective action
Verify if fault is mechanical, electrical or hydraulic	Operate manual lever in both directions to confirm if mechanical or electrical or hydraulic	If moving the manual lever operates the cylinder/motor in both directions check electrical or hydraulic
	If operating the manual lever strokes the cylinder/motor in one direction only, check manual stop screw adjustment	Back out manual stop on manual controller and torque the jam not to 8 Nm [70 lbf-in] Do not exceed maximum torque
	Check movement of manual lever when electrical controller is operated	If manual lever does not move in one direction check electrical signal from controller and wiring at the PVE module
	Check movement of manual lever when hydraulic controller is operated	If manual lever does not move in both directions check hydraulic pressure at the PVG module
Air in system	Entrained air generates heat under pressure	Look for foam or bubbles in reservoir. Check for leaks on inlet side of charge pump.
Internal leakage	Excessive internal leakage may overheat the system.	Install loop flushing defeat option and monitor case flow. If case flow is excessive, motor may require major repair. Contact Danfoss Service.
Shock valves	Swap and see if problem follows	Replace valves
Solenoid actuation	If power is OK from controller	Repair wiring to PVE module
Main spool travel restricted	Stop on manual controller turned in too far	Back out manual stop on manual controller
Remote electrical controller	Insufficient signal from electrical controller	Repair or replace electrical controller
PVEO connections	Incorrect PVE/PVEO connections	Connect correct way
Remote hydraulic controller PVRH	Insufficient pilot oil pressure from remote hydraulic controller Pressure needs to be 25 Bar [360 psi]	Repair or replace remote hydraulic controller

Main valve spool moves without oil passing to cylinder/motor

Cause	Check	Corrective action
Insufficient oil supply to valve	Check the pump per manufacturers procedure	Repair or replace pump per manufacturers procedure
Optional pressure compensator in valve section not functioning	Check compensator spool	Replace spool
Insufficient load pressure at compensator spring chamber	LS drilling holes plugged	Clean or replace
Cylinder/motor load too high for pressure setting of the system	Check pressure at the valve	If pressure is set to spec. per valve lower load on cylinder/motor
Blocked LS galleries	Inspect for blockage in LS galleries	Remove blockage in LS galleries
Shuttle valve faulty	Inspect shuttle valve	Repair or replace
Blocked LS lines to pump controller	Inspect LS lines from PCG to pump controller	Remove blockage in LS lines from the PVG valve to pump controller
Oil bypassing at shock valve/anti-cavitation check valve	Check if stuck open or damaged	Replace valve
Internal leakage in cylinder/motor	Inspect for by-passing of oil per cylinder/motor manufacture per manufactures procedure	Repair or replace cylinder/motor per manufactures procedure
Too much leakage in LS spool in pump control	Check bleed orifice in LS control	Use a LS pump control with no bleed orifice
Blocked thermal orifice	check thermal orifice (blocked)	Replace thermal orifice
Load too high for system	Check for proper system pressure	Adjust pressure to valve specification
Internal leakage in cylinder/motor	Inspect for bypassing of oil per cylinder/motor manufacturer specification	Repair or replace cylinder/motor
Shock valve or anti-cavitation check valve faulty	Inspect for damage and contamination	Repair or replace cylinder/motor
System relief valve pressure set too low for load	Install pressure gauge and check pressure	Adjust pressure to system specification Lower load

System Troubleshooting

Cause	Check	Corrective action
Cylinder/motor load too high for pressure settings of system	Check load pressure at PVB-LS port	Reduce load pressure if exceeds maximum pressure limit of the system
	Maximum system pressure should be approx. 25 Bar [365 PSI] above highest load pressure	Adjust maximum system pressure if necessary
	Adjust pump pressure compensator setting if necessary	

Cylinder/motor operates without remote controller being operated

Cause	Check	Corrective action
Spool control tension rod loose	Confirm torque on spool control tension rod	Torque to 8 Nm [70 lbf·in]
Electrical feedback transducer not in neutral position	Check the feedback pin in the PVE. It should be loose	Replace transducer
Remote electrical controller neutral position switch faulty	Disconnect the connection at the PVE. It should come back to neutral	Repair or replace faulty switch or wiring at remote controller
Sticking pressure control valve in remote hydraulic controller	Disconnect the hydraulic signal line from valve	Repair or replace faulty remote hydraulic controller
Sticking main spool in valve section	Remove manual, electrical, and hydraulic actuators from the valve section. Remove main spool from valve section and inspected for damage. If no damage reinstall the main valve spool. Spool should move freely in the valve section bore.	Replace the valve module and main spool if any damage is found on the main spool
Internal fault in the PVE/PVEH/PVEM/PVEO	PVEO check continuity. All other PVE, check LED (Red means internal error)	Replace faulty PVE/PVEH/PVEM/PVEO
Contamination in the hydraulic oil	Take oil samples to confirm	Flush hydraulic system. Fill with clean filtered oil.

Cylinder/motor responds slowly to remote electrical or hydraulic controller actuation

Cause	Check	Corrective action
Insufficient system pressure	Install pressure gauge and record pressure	If pressure is low adjust pressure setting to valve specification or pump manufacturers specification
Main spool travel limited	Check stops on manual lever controller end for proper adjustment. Refer to Component troubleshooting section.	Adjust the manual lever stops and torque the jam nuts to 8 Nm [70 lbf·in] Do not exceed maximum torque
Incorrect signal voltage from electrical controller	Check the signal voltage from the controller with a volt meter	If signal voltage is incorrect repair or replace electrical controller
Incorrect hydraulic pressure signal from remote hydraulic controller	Check pressure from the remote hydraulic controller - 25 Bar [360 PSI]	If pressure is too low, repair or replace remote hydraulic controller per manufacturers instructions.
Insufficient pilot oil - all sections	Check pilot for contamination and correctly assembled parts - 10-15 bar [145-218 psi] Electric - 25 bar [360 psi] Hydraulic	Replace inlet module NOTE: Check with S-D TST
Insufficient LS pump stand by pressure	Check pilot PSI - 10-15 bar [145-218 psi] Electric - 25 bar [360 psi] Hydraulic	Adjust or replace pump
Flow is not load independent	PVLP check for cracks Check LS pressure vs load pressure	Replace valve

Erratic cylinder/motor response to electrical or hydraulic controller operation

Cause	Check	Corrective action
Electrical actuator faulty	Check signal from controller to PVE	Repair or replace PVE
Main spool centering spring damaged	Check tension rod for correct torque or damage	Torque to 8 Nm [70 lbf·in] or replace

System Troubleshooting

Cause	Check	Corrective action
Main spool position feedback transducer signal incorrect	Check feedback pin for damage	Replace PVE
Contamination in hydraulic oil	Take oil sample	Flush complete system. Fill reservoir with clean filtered fluid per OEM specification
Air in hydraulic pilot lines	Check for air trapped in signal lines from the controller to the valve section module	Bleed air from the hose connection at the valve section
Hydraulic remote actuator faulty	Check signal pressure from the remote hydraulic controller	Repair or replace cylinder/motor
Low hydraulic oil supply	Check fluid level in reservoir	Fill reservoir with clean filtered fluid per OEM specification

Hydraulic oil supply

Cause	Check	Corrective action
Pump not running	Check prime mover for operation	Repair or replace prime mover
	Check condition of drive coupling	Repair or replace drive coupling
Insufficient oil in reservoir	Check fluid level in reservoir	Fill with clean filtered oil
Leaking or burst supply hose	Inspect lines to valve stack	Repair or replace damaged hose
Relief valve malfunction	Check for contamination and operation of relief valve	Repair or replace relief valve
Isolating valves are closed	Check that all isolating valves are open and clear	
Faulty pump control	Check pump compensator for correct operation and setting per pump manufacturers	Repair or replace pump compensator per pump manufacturers recommendations
Low standby pressure in PVP - open center pump	Check idle standby pressure - 10 Bar [145 PSI]	Replace
	Check condition of compensator spool spring	Replace module due to worn components
Low standby pressure in pump control - variable pump	Check pump LS control for operation and setting Stand by pressure should be 15 bar [220 psi] minimum	Repair or replace LS control per pump manufacturers procedures
PVP pressure relief valve faulty	Check pressure relief valve spool and spring for freedom of operation	Replace
PVP orifices blocked	Check PVP orifices for blockage	Remove blockage
Internal filters blocked	Check for blockage in internal filters	Remove blockage
Supply lines blocked	Inspect supply lines for blockages	Remove blockage
Internal hydraulic pilot pressure insufficient	Inspect pilot oil pressure reducing valve for proper operation	Repair or replace
Blocked LS galleries	Check LS galleries for blockage	Clean blockage from LS galleries
Shuttle valves faulty	Check LS system shuttle valves for wear and damage	Replace as needed

Check for contamination per specification **HPP 030**. Refer to *Design Guideline for Hydraulic Fluid Cleanliness, Technical Information Manual 520L0467*. If fluid is out of spec., flush hydraulic system and fill with clean filtered oil.

Electrical supply

Cause	Check	Corrective action
No electrical power	Check electrical circuit	Repair as needed
	Verify emergency stop switch is in the proper operating position	Reset
Neutral position switch faulty	Check operation of neutral position switch in remote controller (if connected in circuit) PVRE/PVRES/PVREL	Replace switch

System Troubleshooting

Cause	Check	Corrective action
Incorrect signal voltage	Check voltage levels at solenoid plug	
	Proportional operation - Refer to Troubleshooting Considerations	
	Udc: Supply voltage (100%)	
	Us: Supply signal voltage (25-50-75%)	
	Ground: Live or ground connection	
	On-Off Operation	
	Udc: Supply voltage if selected	
	Us: Supply voltage if selected	
	Ground: Live or ground connection	
Solenoid valve faulty PVHC	Check coil resistance	Check data for resistance
Insufficient pilot supply	Check pilot pressure - 10-15 bar [145-218 psi]/PVHC 25 bar [360 psi]	Replace
Main spool position feedback transducer signal incorrect	Test oil for contamination and or water content	If oil contamination is too high, flush hydraulic system or replace oil if necessary. If problem persists change PVE
Incorrect PVE connections	Check that the proportional remote electrical controller has not been connected to an ON-OFF PVEO solenoid	Connect wires correctly

Hydraulic (remote) pilot control pressure

Cause	Check	Corrective action
Insufficient pilot pressure	Check pilot oil pressure 5-15 bar [72-220 psi] delta between A and B port on remote	
	PVG32: 5-15 Bar [72-217 PSI]	
Insufficient pilot oil supply	Check pilot oil flow rate is adequate	
	Pilot flow should be 1.0 L/min [0.264 GPM] per section	
	Check pilot lines for blockage	Remove blockage
Air in pilot line	Check for trapped air in pilot lines	Bleed air from pilot lines at PVH
Pilot lines incorrectly sized	Check pressure drop	Check and reduce length or pilot lines
		Increase diameter of pilot lines
		Use steel tube for long pilot line runs
Hydraulic remote pilot operator faulty	Check operation of hydraulic remote pilot controller	Repair or replace
	Check supply pressure to hydraulic remote controller - minimum 25 bar [360 psi]	Repair or replace
	Check and inspect movement of pressure control valve in hydraulic controller	Repair per manufacturers procedure, or replace
	Check operation of remote hydraulic controller	Clean and/or repair as necessary

PVG 32 Component Troubleshooting

Pressure relief valve

Description: Adjustable relief valve. Adjustment range 50 Bar [700 PSI] to 350 Bar [5000 PSI].

Location: The relief is in all PVP Inlet modules

Function: Provides maximum pressure setting above pump pressure setting 30 Bar [450 PSI] Delta for open center and closed inlet sections

Failure mode	Cause	Corrective action
Will not build pressure	Contamination	While under pressure, back out to minimum pressure and allow oil to leak by for approx. 5 seconds and then readjust to correct pressure - Replace valve
External leaking	Damaged seat and poppet	Replace complete assembly
Pressure setting is wrong	Pressure adjustment backs off (on open center application)	Adjust to model code specification
Instability when PC and inlet relief has too low of a delta between them	PC at pump should be set 20 bar below relief valve	Adjust to model code specification

Serviceability: Non serviceable.

Valve removal tool P/N: **155L6485**. Torque to 20 Nm [180 lbf-in].

Pressure reducing pilot valve

Description: Pressure reducing valve at fixed pressure.

Location: The pressure reducing valve is a option in some PVP Inlet modules.

Function: Provides 10-15 bar [145-218 psi] internal pressure for electrical (PVE) actuators or provide 25 Bar (360 PSI) (PVHC) and supply for external remote hydraulic actuators (HRC). These pressures are only present when the load pressures are high enough to satisfy the required regulated pressure. The open center system at low pump flow may only develop 9 Bar (130 PSI)

Failure mode	Cause	Corrective action
Main spools are slow, driven by PVE 13 Bar [190 PSI] pilot system	Contamination	Disassemble and clean
	Pump pressure too low - below 9 Bar [130 PSI]	Closed center: System increase stand-by to 13 Bar [190 PSI] Open center: Check gear per pump manufacture procedure Check system for other components before valve inlet that may provide a path tank
	High tank port pressure. Do not exceed 40 Bar [580 PSI] tank pressure (For PVPs without TO option)	Clear restrictions in return system.
	Oil viscosity 460 mm ² /S [2128 SUS] too high (cold oil or incorrect viscosity oil)	Warm up system or replace oil with correct viscosity
Main spools will not move mechanically or electrical	For TO option only not being connected to tank or restricted to tank	Connect TO (PVP) port option to tank or remove restriction
	Internal pressure reducing valve parts misassembled	Reassemble the internal pressure reducing valve parts correctly
PVHC 25 bar [360 psi] pilot system - main spools are slow	Contamination	Disassemble and clean
	Pump pressure too low - below 20 Bar [290 PSI]	Closed center: System increase stand-by to 20 Bar [290 PSI] Open center: Check gear per pump manufacturers procedure Check system for other components before valve inlet that may provide a path tank
	High tank port pressure. Tank pressure should not exceed 40 Bar [580 PSI] (For PVPs without TO option)	Check for restrictions in return system and remove
	Oil viscosity - 460 mm ² /S [2128 SUS] too high (cold oil or incorrect viscosity oil)	Warm up system or replace oil with correct viscosity

PVG 32 Component Troubleshooting

Serviceability: All internal components can be removed from the cavity, cleaned, inspected and reassembled back into the valve

1. Use a 6 mm internal hex wrench to remove the plug, and then remove all the other internal components in the cavity
2. Clean all components with clean solvent
3. Replace any damaged components. Lubricate with clean hydraulic oil
4. Correctly reassemble the components back into the cavity and torque the plug to 25 Nm [221 lbf·in] (use an M5 screw to install spool).

Pressure reducing pilot valve

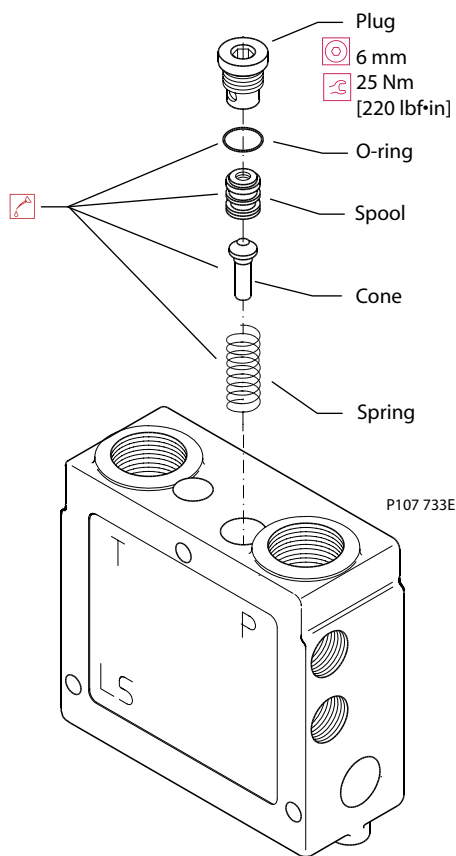

Pressure gauge connection

Description: Port to install a pressure gauge to check pressure relief valve setting to valve specification.

Location: On inlet cover to valve stack.

1. Use a 6 mm internal hex to remove and install plug.
2. Torque plug to 35 Nm [308 lbf·in].

Failure mode	Cause	Corrective action
Leaking	Bad seal	Replace with new seal (same type as original seal)

PVG 32 Component Troubleshooting

Pressure gauge port

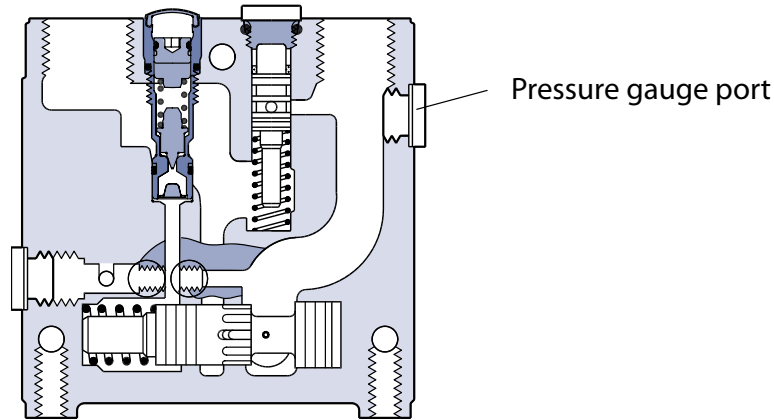

P107 735E

When valve is equipped with the PVPC option use a running tee to measure pressure. Torque tee to hose adaptor torque specification.

PVPC with check valve

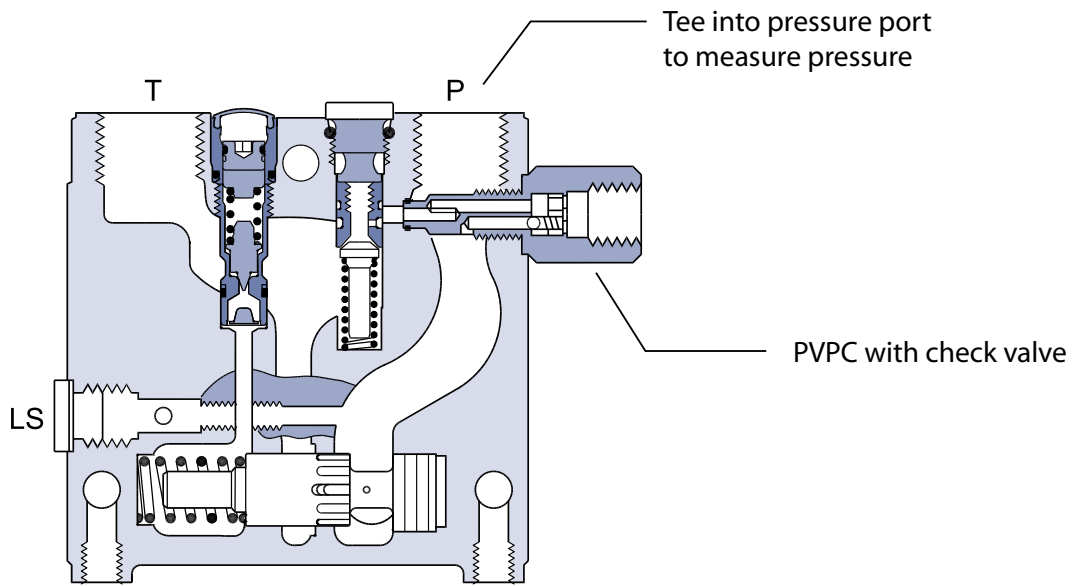

P107 734E

Open center plug

Description: Plug that is installed in the inlet cover for a system with a fixed displacement pump.

Location: In the PVP module (Inlet cover).

Function: Connection for the load sense signal to shift the unloading spool to build main system pressure and provides a connection to the main system relief valve.

Failure mode	Cause	Corrective action
Valve operates at system relief setting at all times	Open center plug is not seated properly	Reinstall plug and torque to 4 Nm [35 lbf·in] using a 3 mm internal hex wrench

PVG 32 Component Troubleshooting

Serviceability: Open center plug is serviceable.

1. Use a 6 mm internal hex to remove cavity plug from valve.
2. Use a 3 mm internal hex to remove open center plug.
3. Clean or replace open center plug.
4. Install open center plug.
5. Torque plug to 4 Nm [35 lbf·in].
6. Install new seal washer and install cavity plug. Torque to 35 Nm [130 lbf·in].

Open center plug

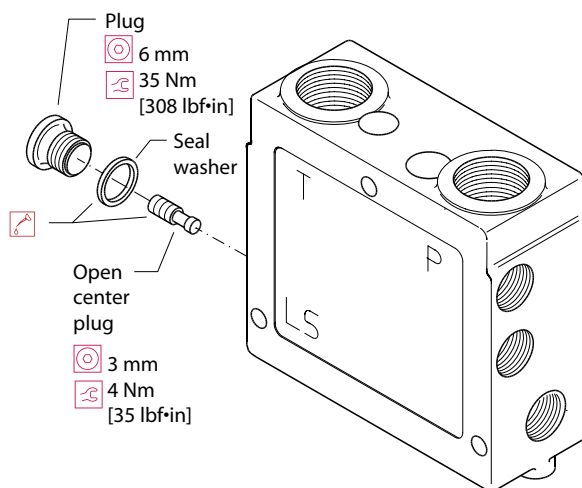

P107 736E

Closed center plug and orifice

Description: Plug that is installed in the inlet cover for a system with a variable displacement pump.

Location: In the PVP module (Inlet cover).

Function: Allow connection for the load sense signal to the pump and provide connection to the main system relief valve.

Failure mode	Cause	Corrective action
Valve operates at system relief setting at all times	Plug and orifice are not seated properly	Reinstall orifice and torque to 4 Nm [35 lbf·ft] using a 3 mm internal hex wrench. Reinstall plug and torque to 8 Nm [71 lbf·in] using a 8 mm internal hex wrench
Can not adjust main relief above pump pressure setting of 30 Bar [450 psi] Delta for closed inlet sections	Orifice is plugged	Remove and clean orifice. Reinstall

Serviceability: Closed center plug and orifice are serviceable.

1. Use a 6 mm internal hex to remove cavity plug from valve.
2. Use a 4 mm internal hex to remove closed center plug.
3. Use a 2.5 mm internal hex to remove orifice.
4. Clean or replace orifice. Install orifice. Torque to 4 Nm [35 lbf·in].
5. Install new seal and install closed center plug. Torque to 8 Nm [71 lbf·in].
6. Install new O-ring and install plug. Torque to 35 Nm [130 lbf·in].

PVG 32 Component Troubleshooting

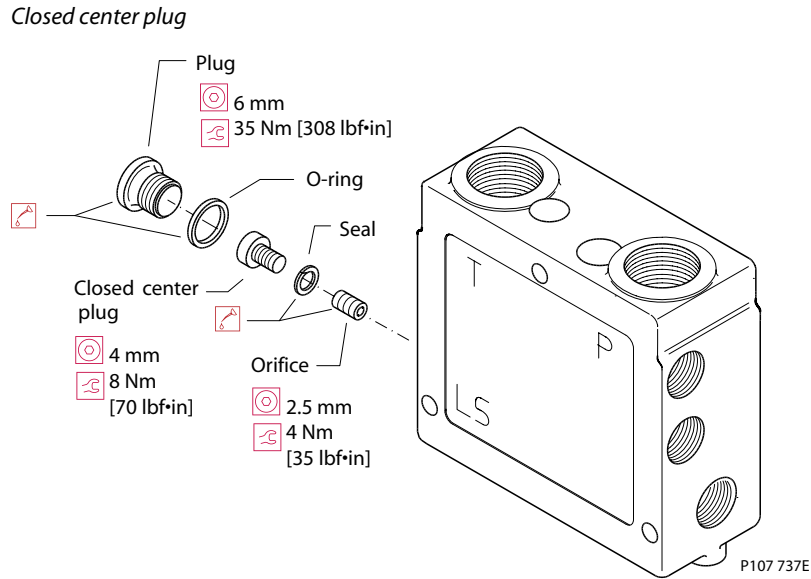

Pressure adjustment spool

Description: Main pump flow unloading spool.

Location: PVP (inlet) module.

Function: For open center systems it is the main relief and unloading spool

For closed center systems it is the main relief spool.

Failure mode	Cause	Corrective action
In open center systems the valve sections are unstable	High wear allows leakage to tank	Replace complete module
The adjusted pressure will not remain static in a closed center system	Low viscosity oil allowing high leakage around spool to tank.	Remove and clean orifice. Reinstall
	High wear	Replace complete module

Serviceability: Spool is not serviceable. Replace complete module.

Pressure adjustment spool

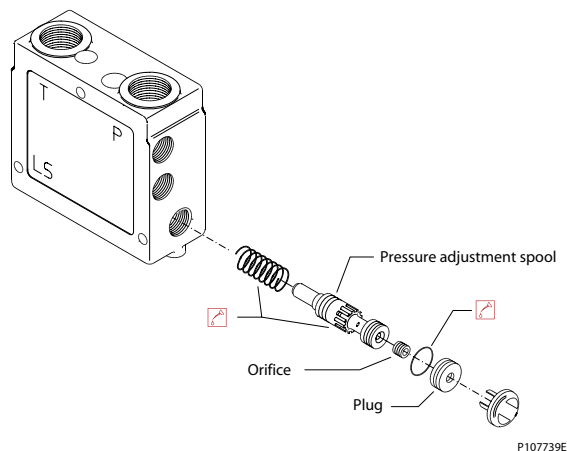

PVG 32 Component Troubleshooting

LS connection

Description: Port for LS signal for LS (static) option only controller for variable flow pump.

Location: PVP (inlet) module.

Function: Provide a signal to the variable pump controller to create a pressure differential to have the pump come on stroke for a closed center system.

Failure mode	Cause	Corrective action
In closed center systems the valve sections are unstable	Insufficient LS flow to satisfy pump controller	Ensure that the LS controller on the pump does not have excessive internal leakage - 0.4 l/min [0.106 gal/min]. Repair or replace the variable pump controller per pump manufactures specifications. If there is more than one valve in the system ensure that the LS shuttles are all working properly
	Excessive air entrained in the hydraulic oil	Ensure that the oil has enough dwell time in tank, has good anti-foaming agent, and pump inlet vacuum is within manufactures specifications
	Air trapped in LS line	Bleed air for LS line at highest point
Valve operation is slow to respond or does not respond	Insufficient LS flow to satisfy pump controller	If more than one section, ensure that the LS controller on the pump does not have excessive internal leakage. Repair or replace the variable pump controller per pump manufactures specifications
	Excessive air entrained in the hydraulic oil	Ensure that the oil has enough dwell time in tank, has good anti-foaming agent, and pump inlet vacuum is within specifications
	Air trapped in LS line	Bleed air for LS line at highest point

PVG valve is mounted above hydraulic oil reservoir when shut down and sits idle for some time, the valve could be voided of oil and this would cause the valve to operate erratically and be slow to respond.

Serviceability: Port is serviceable. Need to connect hose to LS port on pump.

LS connection plug

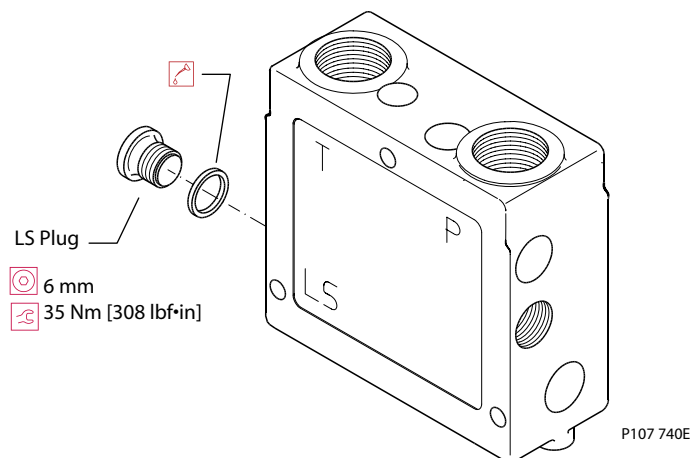

LS signal

Description: The PVG32 uses an internal LS signal network for both Open Center and Closed Center systems. In Open Center systems the internal LS signal network provides a resolved load sense signal to the pressure adjustment spool controlling the proper amount of flow and pressure to the operating valve sections. In Closed Center systems the internal LS signal network provides a resolved load sense signal directly to the LS pump control which in turn provides the proper amount of flow and pressure to the operating valve sections.

Location: PVP/PVB Modules.

PVG 32 Component Troubleshooting

Function: Directs the highest load pressure to either OC or CC pump control to satisfy the operating valve section.

Failure mode	Cause	Corrective action
No pump pressure developed in one or more valve sections	LS passages blocked or restricted	Disassemble valve. Inspect passages for blockage

Serviceability: Not serviceable. Ensure entire system is clean.

LS circuit

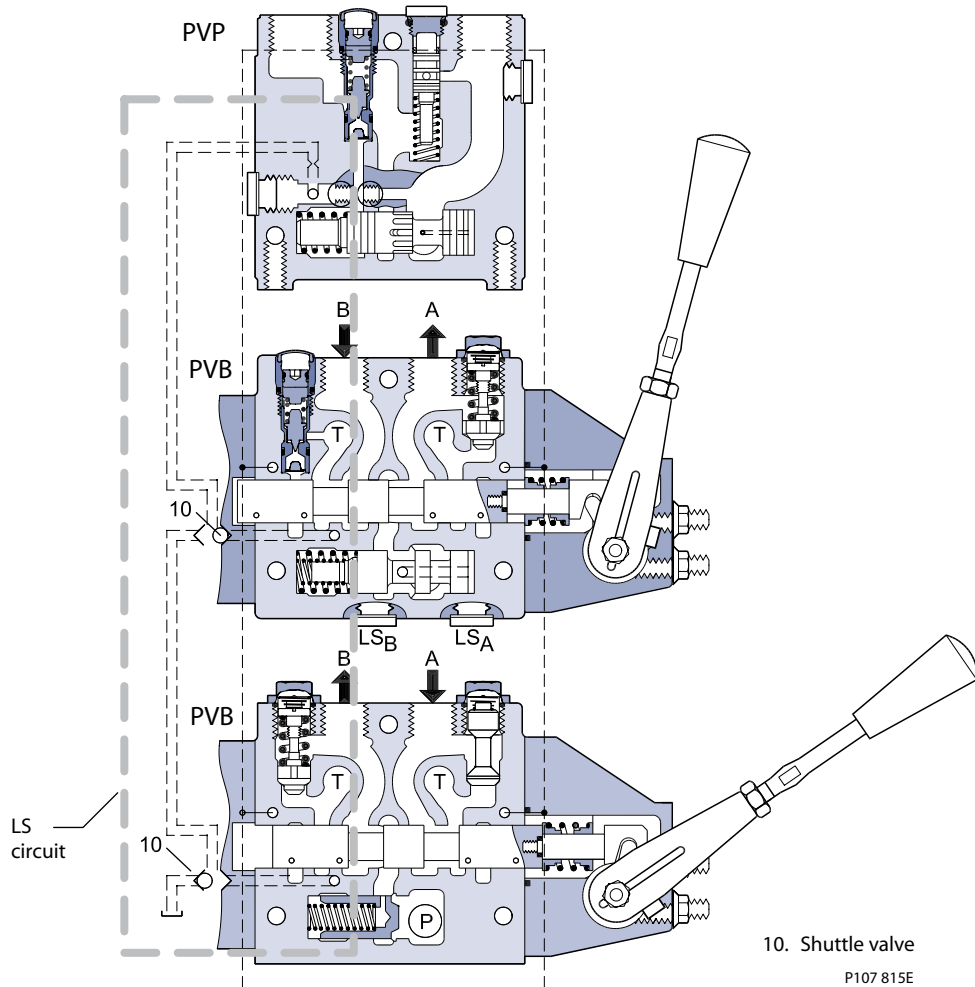

Shuttle valve

Description: Self cleaning internal shuttle system.

Location: PVB (valve section) module.

Function: Determines which valve section is developing highest load pressure.

Failure mode	Cause	Corrective action
Valve sections will not build pressure (NOTE: Normally it will be one section, but not all sections)	Worn shuttle disc	Replace complete module (seat is pressed into module)
	Excessive air entrained in the hydraulic oil	Ensure that the oil has enough dwell time in tank, has good anti-foaming agent, and pump inlet vacuum is within specifications

Serviceability: Not serviceable. Ensure entire system is clean.

PVG 32 Component Troubleshooting

Shuttle valve

Exploded view shows internal parts.
 Do not disassemble valve.

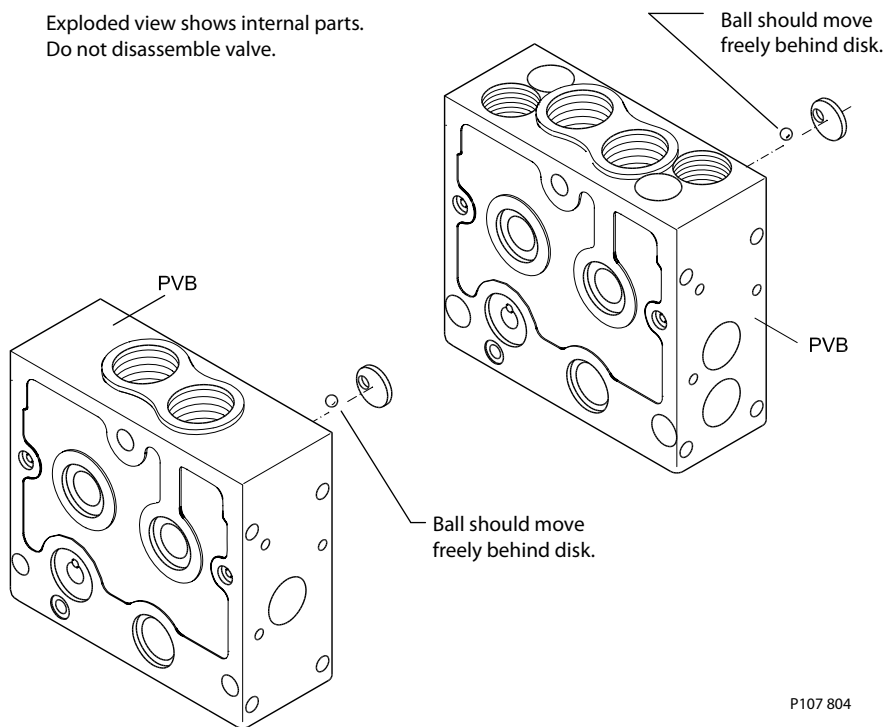

P107 804

LS pressure limiting valve

Description: Optional adjustable pilot relief valve.

Location: PVB (spool body section) module.

Function: Controls the maximum working pressure delivered to each work port.

There is one LS pressure limiting valve for each work port.

Failure mode	Cause	Corrective action
Section will not build pressure in one spool direction	Contamination	While under pressure back out to minimum pressure and allow oil to leak by for approx. 5 seconds and then readjust to correct pressure - Ensure system is clean - Replace PVB
External leaking	Low cartridge torque	Torque to 20 Nm [177 lbf·in] maximum Replace complete assembly
Pressure adjustment backs off	Adjust pressure to valve specifications	If adjustment doesn't hold, replace valve

Serviceability: Adjustable and non-serviceable. If adjustment does not solve the problem, replace complete cartridge.

Valve removal tool P/N: **155L6485**. Torque to 20 Nm [177 lbf·in].

LS A, B shuttle

Description: The shuttle valve isolates the LS(A) and LS(B) load sense signal.

Location: Option PVB module with only load sense relief.

Function: Ensure that each pressure limiter valve can create separate pressures for A and B LS signal.

PVG 32 Component Troubleshooting

Failure mode	Cause	Corrective action
Will not build pressure in A or B work port	Contamination preventing shuttle ball from building load sense relief pressure	Replace complete PVB module

LS A, B shuttle

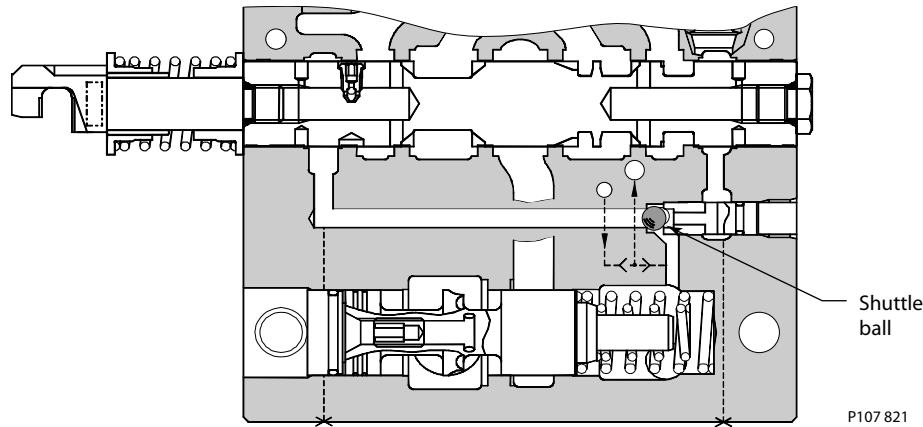

Main spool

Description: Main directional control.

Location: PVB (valve section) module.

Function: Controls oil flow from pump to work ports A or B.

Failure mode	Cause	Corrective action
Section will not build pressure in one spool direction	Load sense passages in spool are blocked	Flush out load sense passages in the spool. Spool will need to be removed to clean
Main valve spool stuck in valve body (if being used with electrical actuator)	Refer to Pressure reducing valve	Replace PVM and PVE. Be sure that pilot valve is assembled correctly.
Mechanical actuator main valve spool stuck in valve body	Hard particle binding spool in bore	Look down into the A and B work ports to see if the particle can be removed while the spool is in the valve body. Replace valve section. NOTE: Valve body and spool will need to be replaced per valve specifications
Main spool stuck in valve body	Tie rod over torqued	Replace tie rod kit which includes section seals and torque to 28 Nm [248 lbf-in]
	Valve stack mounting surface is not flat causing a bind on the valve stack	Ensure the mounting surface is flat*

* Flatness in millimeters - T= 0.35 mm X number of PVB modules + 1

Serviceability: Main spool is serviceable depending on failure mode.

1. Remove manual actuator using a 5 mm internal hex wrench to remove the 4 mounting screws.

CAREFULLY place the main spool in to an appropriate fixture or vice with card board, rubber hose or heavy shop towels on the jaws and tighten just enough to keep the spool from turning in the vice. DO NOT over tighten the main spool in the vice as it will be distorted and or scratched on sealing lands and the spool will need to be replaced.

2. Remove the tension rod end using a 13 mm open end wrench.
3. Remove the plug at the other end using an 11 mm, or if it has a detent option, use a 12 mm open end wrench.
4. Flush out openings into the main spool cavity at each end.

PVG 32 Component Troubleshooting

5. Install plug with a 11 mm or 12 mm open end wrench. Torque to 8 Nm [70 lbf·in].
6. Install centering spring and tension rod using a 13 mm open end wrench and torque to 8 Nm [70 lbf·in].
7. Carefully reinstall the main valve spool into the valve housing. Do not force the main spool back into the housing as you will damage the sealing lands in the valve housing. The spool should move freely in the main spool bore when fully installed.
8. Install a manual actuator. Reassemble in reverse order and torque the 4 mounting screws to 8 Nm [70 lbf·in]

If section does not build pressure in one direction, wrong spool may have been installed in valve.

Main spool

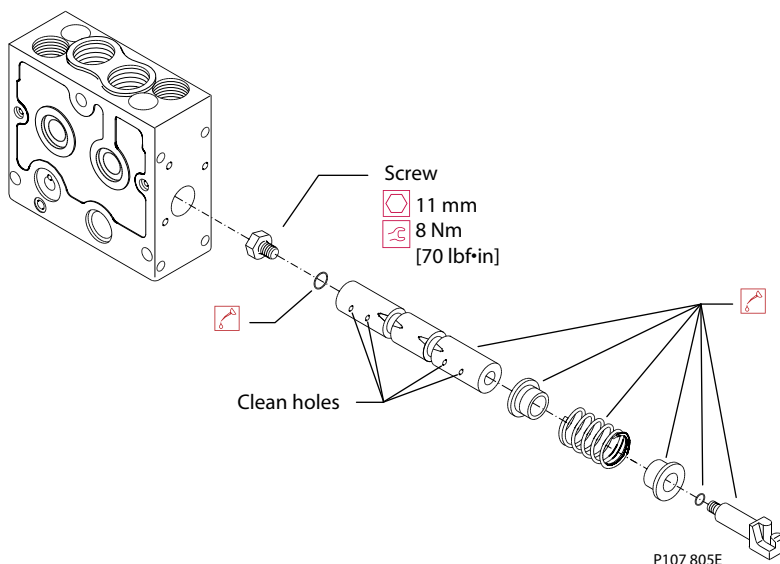

Shock and anti-cavitation valve PVLP

Description: Optional work ports non adjustable pressure relief valve.

Location: PVB (valve section) Module.

Function: Removes any transient pressure spikes generated by the load.

The shock valves PVLP with fixed setting and the anti-cavitation valves PVLA on ports A and B are used for the protection of the individual work function against overload and/or cavitation.

There is one shock valve for each work port.

Failure mode	Cause	Corrective action
Will not build pressure in A or B port	Valve may be damaged and not able to seal	Replace with correct part number per valve specification

Serviceability: This valve may be disassembled and cleaned, however, internal parts are not available separately. If you suspect valve malfunction, replace with a new valve and test system operation.

PVG 32 Component Troubleshooting

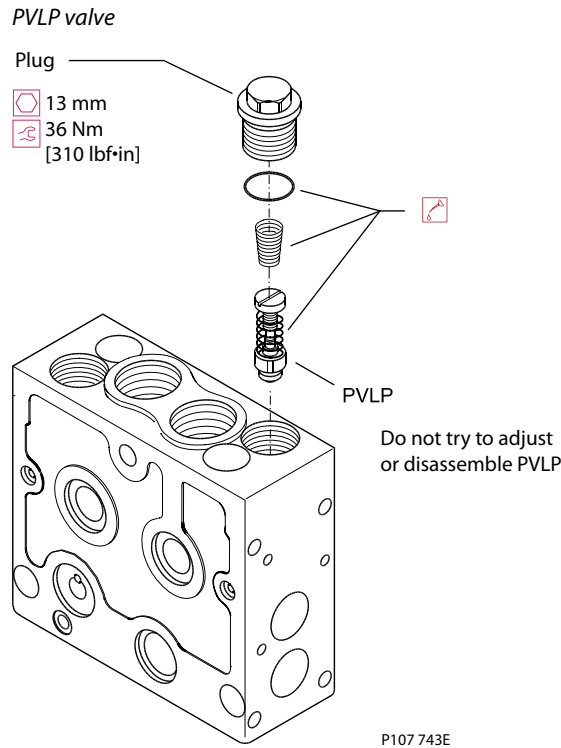

Pressure compensator

Description: Optional pressure compensator maintains a constant pressure drop across the main spool.

Location: PVB (Valve section) Module.

Function: In a pressure-compensated basic module the compensator maintains a constant pressure drop across the main spool – both when the load changes and when a module with a higher load pressure is actuated.

Failure mode	Cause	Corrective action
Valve section unstable flow	High wear allows leakage	Replace complete module
LS pressure limiting valve pressure adjustment will not remain static	High wear	Replace complete module

Serviceability: Pressure compensator is not serviceable. If you suspect valve malfunction, replace complete module.

PVG 32 Component Troubleshooting

Pressure compensator valve

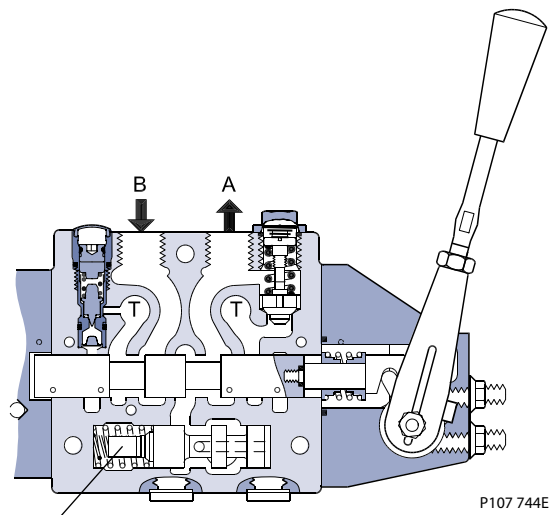

Pressure compensator spool

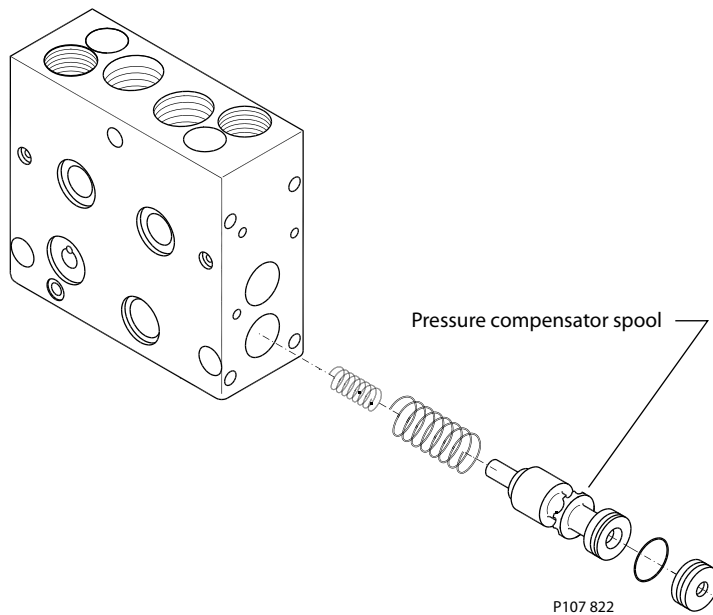

Load drop check valve

Description: Keeps the load from dropping when transitioning from spool neutral to lifting the load.

Location: PVB (valve section) module.

Function: Optional drop check to keep the load from dropping. Prevents high pressure functions from supplying low pressure functions when both are actuated simultaneously.

Failure mode	Cause	Corrective action
Load drops excessively when trying to lift load	Worn parts.	Replace complete PVB module
	Hard particle in seat area does not allow the seat to seal	Replace complete module

Serviceability: Load drop check valve is not serviceable. If you suspect valve malfunction, replace complete module.

PVG 32 Component Troubleshooting

Load drop check valve

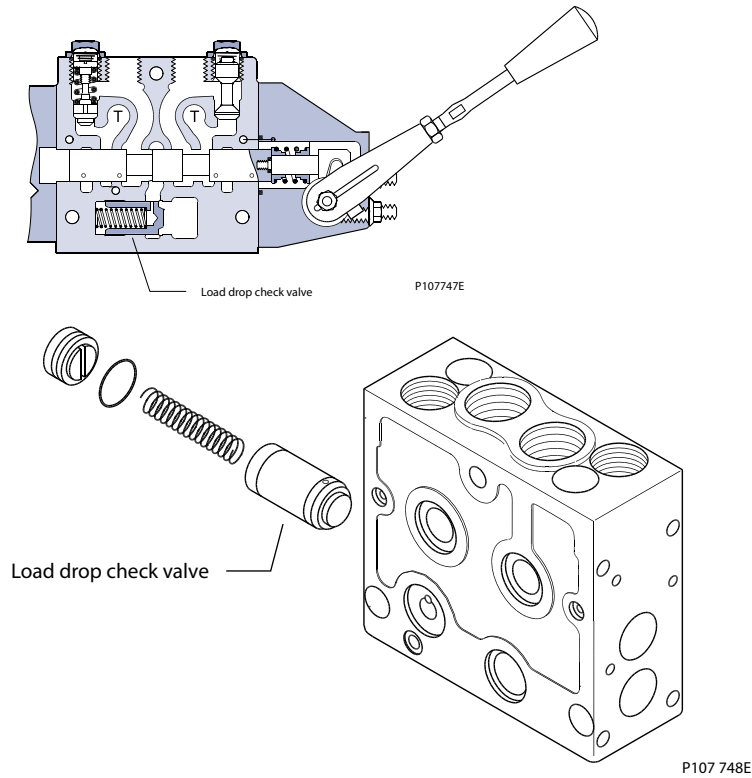

Maximum oil flow adjustment screws for ports A and B

Description: Optional mechanical flow limiter.

Location: PVM manual control handle.

Function: Determines the stroke of the main spool in the PVB.

Failure mode	Cause	Corrective action
Cylinder/motor functions too slow or too fast	Mechanical stop screws out of adjustment per valve spec.	Use a 8mm open end wrench to loosen the jam nut and then 3mm internal hex wrench to adjust the mechanical adjusting screw CCW to increase speed. After adjusting hold the adjusting screw and torque the jam nut to 8 Nm [70 lbf·in] maximum
Leaking past adjusting screws	Check torque on seal nut 8 Nm [71 lbf·in]	Retorque or replace seal nuts

⚠ Caution

When adjusting main spool flow ensure that electrical or hydraulic actuators are not active at the time, if so equipped.

PVG 32 Component Troubleshooting

Adjusting screws for ports A and B

For standard mount, top adjusting screw is B and bottom adjusting screw is A

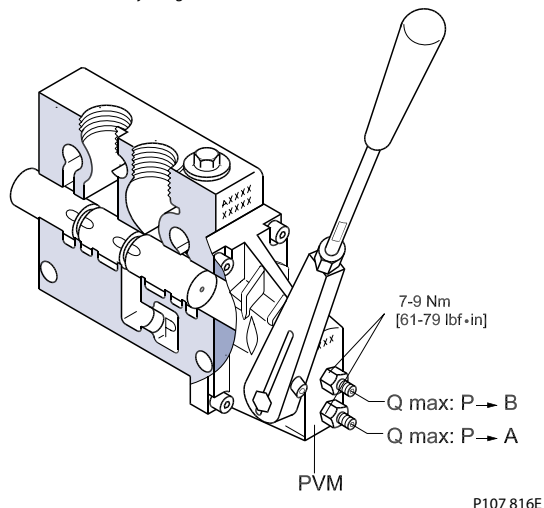

PVM module

Description: Manual control lever.

Location: Mounted on either end of the PVB main spool.

Function: Manual override capable of limiting the stroke of the main spool, and is used to center the spool in neutral.

Failure mode	Cause	Corrective action
Leaking externally between PVM and PVB	Back pressure is exceeding 40 Bar [580 PSI] on tank line	Replace PVM module, seals, and lower tank port pressure
	T0 port not connected to tank or restricted or blocked	Connect to tank, remove restriction, and remove blockage

PVG 32 Component Troubleshooting

PVM module

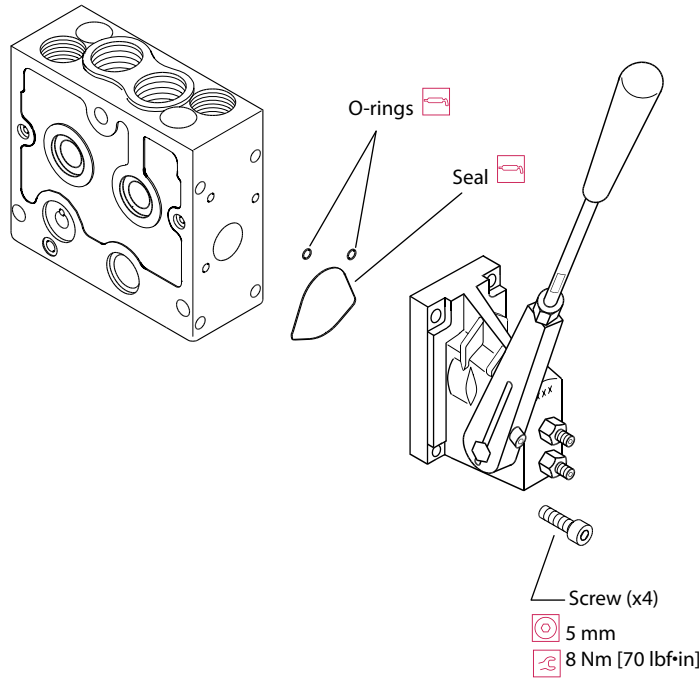

P197 806E

PVS module

Description: End cover.

Location: Mounted on the last PVB of the valve stack.

Function: Serves as blanking cover and drain for LS circuit.

Failure mode	Cause	Corrective action
Leaking externally between PVS and PVB	Back pressure is exceeding 40 Bar [580 PSI] on tank line	Replace PVS module, seals, and lower tank line pressure
	Maximum pressure: Aluminum - 300 bar [4500 psi] Steel - 350 bar [5000 psi]	Reduce system pressure

PVG 32 Component Troubleshooting

PVS plugs

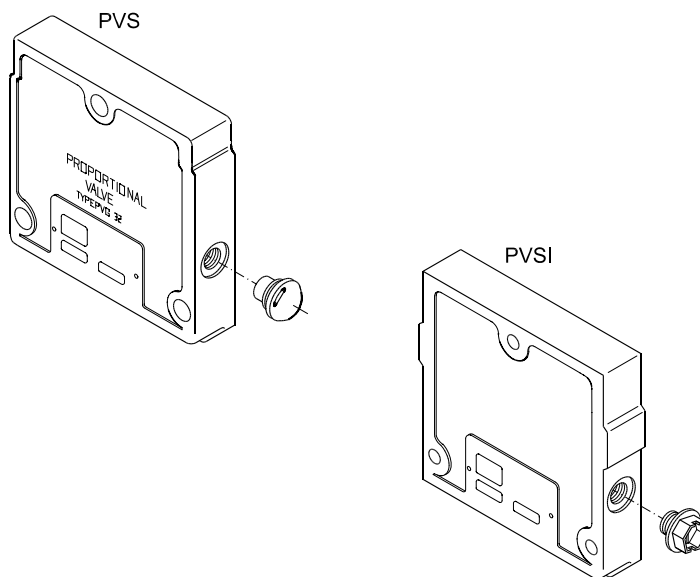

P107 707E

For specifications and operating parameters on PVG 32 valves, refer to PVG 32 Technical Information Manual **520L0344**.

PVPVM module

Description: Mid-inlet module only for closed center systems.

Location: Mounted between multiple PVB's in a valve stack.

Function: Provides pressure and tank connections to the valve stack allowing increased flow.

Failure mode	Cause	Corrective action
Leaking externally between PVPVM and PVB	Uneven mounting surface and mounting screw torque	Ensure the valve stack is mounted on a even surface and torque down correctly
	Tie rods torqued too tight	Replace tie rod kit which include section seals and torque to 28 Nm [248 lbf·in]
	Flow exceeding 61 gpm	Lower flow to 61 gpm, and replace the tie rod kit and seals
Valve stack can not build pressure per valve spec.	Option PVL P (shock valve) not seating correctly in cavity caused by valve not being installed correctly or it has failed	Install components correctly or replaced damaged components

* Flatness in millimeters - T= 0.35 mm X number of PVB modules + 1

PVG 32 Component Troubleshooting

PVPVM module

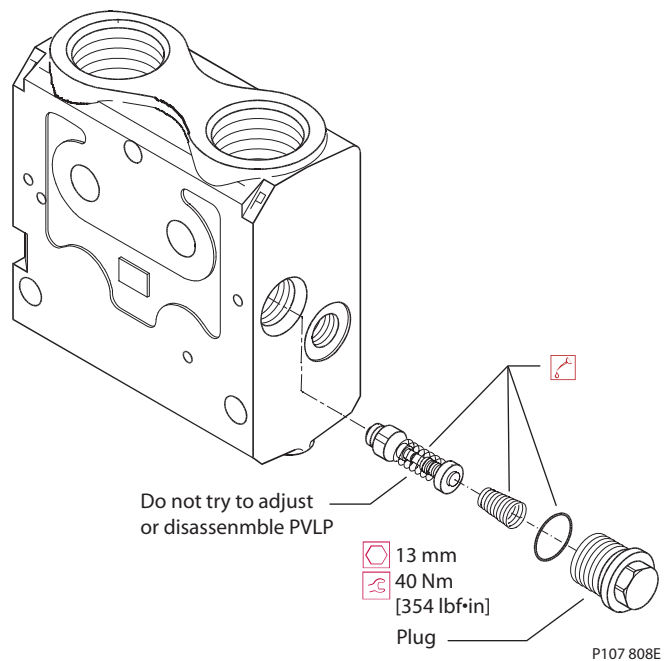

PVAS module

Description: Tie rod kit.

Location: Through the valve stack.

Function: Holds the stack together.

Failure mode	Cause	Corrective action
Leaking externally between sections	Tie rods under torqued	Check and retorqued - 28 Nm [248 lbf·in]
	Tie rods torque too tight	Replace and retorqued - 28 Nm [248 lbf·in]

PVG 32 Component Troubleshooting

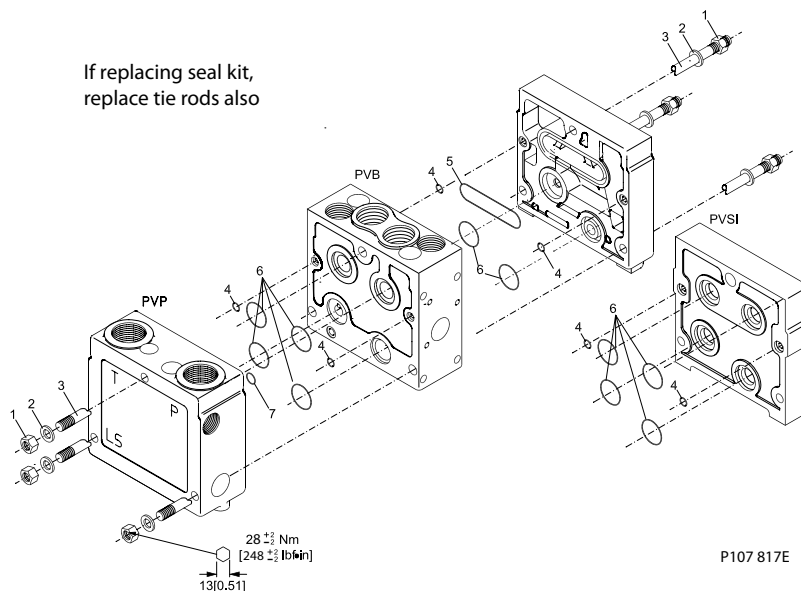

PVPX LS unloading valve

Refer to [PVPX Electrical LS unloading valve](#) for valve operation.

Description: Optional two way two position solenoid.

Location: In the PVP.

Function: A safety device that dumps load sense to tank to prevent the pump from building pressure.

Failure mode	Cause	Corrective action
Manual override leaking externally	Not torqued correctly	Check and retorque to 45 Nm [400 lbf·in]
	High usage	Replace per valve specification
	Manual override is bent	Replace per valve specification
Solenoid will not shift	Coil not working	Replace coil per valve specification Check with OHM meter: 12 volt system - 8.7 OHMs 24 volt system - 33 OHMs
	Too high or too low of voltage	Confirm voltage in system from remote controller: 12 volt system should not exceed 13.2 volts 24 volt system should not exceed 26.4 volts

PVG 32 Component Troubleshooting

PVEM, PVEA, PVEH, PVES electrical actuators

Description: Proportional electrical actuator.

Location: On the end of the main spool of the PVB.

Function: Convert an electrical command to move the main spool to a set position.

Troubleshooting Considerations

Wiring Check: It is highly possible that in the case of one PVE failing that there could be a poor connection between the joystick and the PVE in question. The PVE is reverse polarity protected and suppression protected; however an intermittent connection could degrade the input electronics to a point of failure. Inspect all wiring and connectors for corrosion and or pinch points.

Hirshman Receptacle and Mating Connector: Each PVE is supplied with a field installable 4-pin Hirshman mating connector and gasket. It is recommended that the gasket be installed between the mating connector and PVE receptacle also the rubber grommet be sealed around a multi-wire jacket in order to seal off moisture from the wiring connections. The PVE is rated for IP65 only when the Hirshman connector is sealed.

Temperature Capability: The PVE ambient temperature range is rated at -40 to 90 °C. Oil temperature wise, the area of the valve that creates the highest horsepower loss usually creates the highest temperature in the system. If one PVE section is operated more frequently than others this would create more heat than any other part of the valve. Under these conditions it is extremely important to insure that the hydraulic system is well cooled. Oil temperature measurements at the reservoir and at the center of the PVG32 valve stack. The valve should be mounted to provide the best ventilation for the PVE electronics. Poor filtration and low fluid levels may also add to temperature.

Troubleshooting

Failure mode	Cause	Corrective action
Does not work in either direction LED is green	No control voltage from the electrical controller	Check voltage from the electrical controller (25% to 75% of supply)
	Command pin wire in mating connector is broken	Repair broken wire
	Connector corroded - This condition is caused by water ingress or ground connection	Replace PVE and mating connector
Does not work in either direction LED is off	No power from the battery	Check power to electrical actuator
	Power pin wire in mating connector is broken	Repair broken wire
	Connector corroded - This condition is caused by water ingress or ground connection	Replace PVE and mating connector
	Ground connection must be hard wired straight from the battery or from the electrical controller	Repair ground connection
LED is flashing Red	Control signal is out of range	Check wiring harness for short
Works in one direction (Assuming that the manual control lever and the main spool move freely both directions)	No control voltage from the electrical controller	Ensure voltage from the electrical controller exists for that direction
	Lack of voltage to actuator (Minimum voltage 11 volts for 12 volt system and 22 volts for 24 volt system)	Check system voltage
	Electrical actuator is defective	Replace electrical actuator per spec. on the valve
Works intermittently (if LED is green it indicates a long on/off)	Loose connection between the electrical actuator and controller	Repair connector
	Electrical actuator is defective	Replace electrical actuator per spec. on the valve
	Short in wiring harness	Repair wiring harness
Works with no command from controller	Short in wiring harness	Repair wiring harness
	Electrical actuator position feed back out of adjustment	Replace the electrical actuator per valve spec.
	Fine particulate contamination	Replace PVE or electric actuator per valve specs.

PVG 32 Component Troubleshooting

Checking input control signal:

1. Install volt meter to ground pin connection and signal pin with PVE in circuit.
2. Turn the power on for the electrical controller.
3. Actuate the electrical controller and read the voltage.
4. The control voltage should be per the electrical controller output signal.

On electrical actuators - coil resistance can not be measured at the pins.

When replacing an electrical actuator be sure that it has the same part number on it to ensure original functionality.

If filter in the electrical actuator has pieces of contamination trapped in it, this is a good indication that the complete system is contaminated and needs to be flushed. The filter in the electrical actuator can be removed and cleaned.

PVEO ON/OFF electrical actuator

Description: ON/OFF electrical actuator.

Location: On the end of the main spool of the PVB.

Function: Convert an electrical command to move the main spool to a set position.

Troubleshooting

Failure mode	Cause	Corrective action
Does not work in either direction	No control voltage from the electrical controller	Check voltage from the electrical controller Resistance check (measures between pin 2 and ground): 17 OHMs for 12 volt systems 63 OHMs for 24 volt systems
	Command pin wire in mating connector is broken	Repair broken wire
	Connector corroded	Replace PVE and mating connector This condition is caused by water ingress or ground connection
	24 volt electrical actuator used on a 12 volt system	Replace with the correct electrical actuator for a 24 volt system
	No power from the battery	Check power to electrical actuator
	Power pin wire in mating connector is broken	Repair broken wire
	Ground connection must be hard wired straight from the battery or from the electrical controller	Repair ground connection
Works in one direction (Assuming that the manual control lever and the main spool moves freely both directions)	No control voltage from the electrical controller	Check voltage from the electrical controller is there for that direction
	Lack of voltage to actuator (Minimum voltage 11 volts for 12 volt system and 22 volts for 24 volt system)	Check system voltage
	Electrical actuator is defective	Replace electrical actuator per spec. on the valve
Works intermittently	Loose connection between the electrical actuator and controller	Repair connector
	Electrical actuator is defective	Replace electrical actuator per spec. on the valve
	Short in wiring harness	Repair wiring harness
Works with no command from controller	Fine contamination	Replace the electrical actuator per valve spec. and flush the complete system and fill with filtered oil
	Short in wiring harness	Repair wiring harness

PVG 32 Component Troubleshooting
Checking input control signal

1. Install a volt meter to the ground pin connection and to the signal pin.
2. Turn the power on for the electrical controller.
3. Actuate the electrical controller and read the voltage.
4. The control voltage should be per the electrical controller output range.

PVE Series 4/7 Connectors
PVEO/PVEO-R/PVEO-HP

Connector	Pin 1	Pin 2	Pin 3	Pin 4
1x4 AMP	Udc_A	Udc_B	GND	GND
1x4 DEU	Udc_A	GND	GND	Udc_B
1x4 DIN	Udc_A	Udc_B		GND

PVEO-DI

Connector	Pin 1	Pin 2	Pin 3	Pin 4
2x4 AMP (A)	Udc_A	Udc_B	GND	GND
2x4 AMP (B)	DI-B	DI-A	GND	Udc ₂

PVEM

Connector	Pin 1	Pin 2	Pin 3	Pin 4
1x4 DIN	Udc	Us	Error	GND

PVEA/PVEH/PVES

Connector	Pin 1	Pin 2	Pin 3	Pin 4
1x4 AMP	Us	Udc	GND	Error
1x4 DEU	Us	Error	GND	Udc
1x4 DIN	Udc	Us	Error	GND

PVEA-DI/PVEH-DI

Connector	Pin 1	Pin 2	Pin 3	Pin 4
2x4 AMP (A)	Us	Udc	GND	Error
2x4 AMP (B)	DI-A	DI-B	GND	Udc ₂
2x4 DEU (A)	Us	Error	GND	Udc
2x4 DEU (B)	Udc ₂	GND	DI-A	DI-B

PVEH-FLA

Connector	Pin 1	Pin 2	Pin 3	Pin 4	Pin 5	Pin 6
1x6 AMP	Us	Udc	GND	Error	Float	
1x6 DEU	Us	Error	Float		GND	Udc

PVEH-SP/PVES-SP

Connector	Pin 1	Pin 2	Pin 3	Pin 4	Pin 5	Pin 6
1x6 DEU	Us	Error		SP	GND	Udc

PVG 32 Component Troubleshooting

PVEP

Connector	Pin 1	Pin 2	Pin 3	Pin 4	Pin 5	Pin 6
1x6 DEU	PWM_A	Error	PWM_B	Udc	GND	

PVED-CC

Connector	Pin 1	Pin 2	Pin 3	Pin 4
2x4 AMP (A/B)	CAN_L	Udc	GND	CAN_H
2x4 DEU (A/B)	CAN_H	CAN_L	Udc	GND

PVE Series 5 Connectors

PVED-CC

Connector	Pin 1	Pin 2	Pin 3	Pin 4
2x4 AMP (A/B)	CAN_L	Udc	GND	CAN_H
2x4 DEU (A/B)	CAN_H	CAN_L	Udc	GND

Connector diagrams

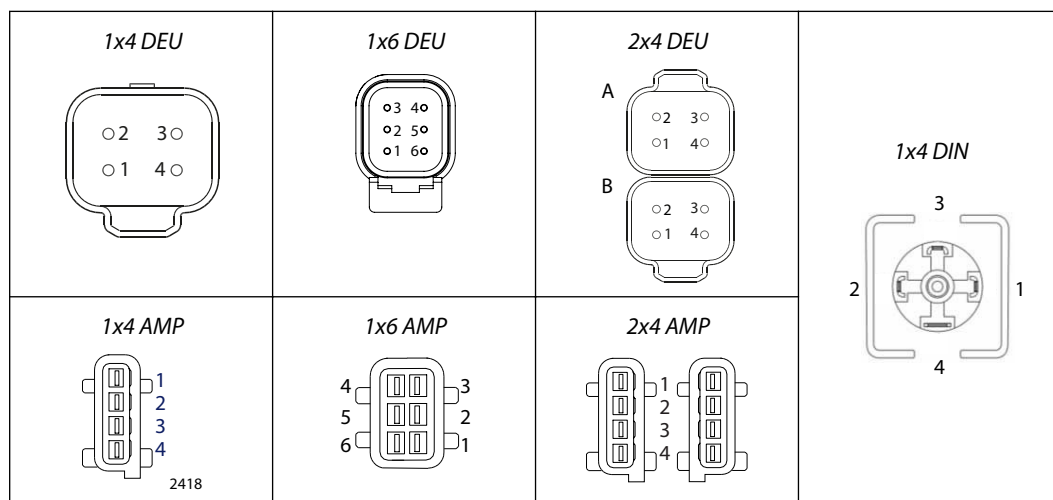

PVG 32 Component Troubleshooting

PVPC plug for external pilot control

Description: Pilot oil supply from another pump.

Location: On the end of the PVP.

Function: Provides a hydraulic pilot supply to the valve stack.

Failure mode	Cause	Corrective action
Main spool moves slow, or not at all, in all sections	External hydraulic pilot pressure is too low	Check external hydraulic pressure from pilot pump and/or restrictions

PVPC plug for external pilot

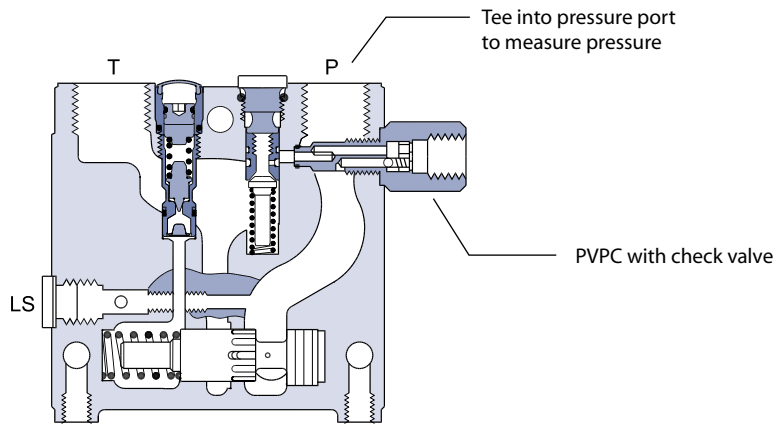

P107 734E

PVMR Friction Module

Description: Mechanical friction hold.

Location: Mounted on main spool in the PVB.

Function: Infinite mechanical positioning of the main spool.

Failure mode	Cause	Corrective action
Flow changes	Excessive flow across the main spool	Reduce flow (100 l/min or less)
	Vibration	Reduce vibration
	Broken spring	Replace broken springs
Flow changes or will not stay in detent	Check for proper assembly of parts	Install parts correctly per specification sheet

PVG 32 Component Troubleshooting

PVMR module

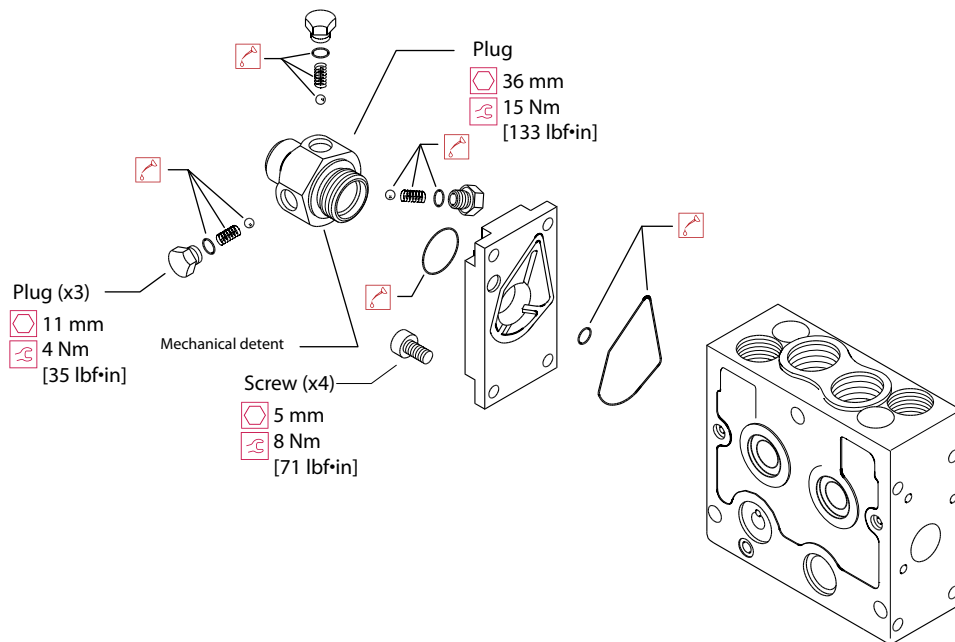

P107 811E

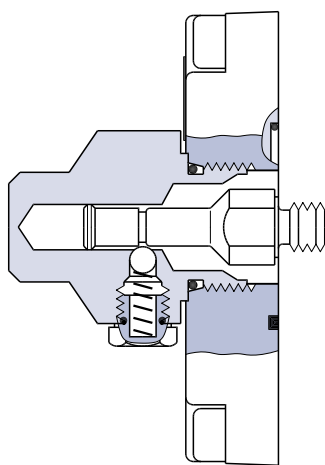

157-204.10

Comatrol

www.comatrol.com

Turolla

www.turollaocg.com

Hydro-Gear

www.hydro-gear.com

Daikin-Sauer-Danfoss

www.daikin-sauer-danfoss.com

Local address:

**Danfoss
Power Solutions (US) Company**
2800 East 13th Street
Ames, IA 50010, USA
Phone: +1 515 239 6000

**Danfoss
Power Solutions GmbH & Co. OHG**
Krokamp 35
D-24539 Neumünster, Germany
Phone: +49 4321 871 0

**Danfoss
Power Solutions ApS**
Nordborgvej 81
DK-6430 Nordborg, Denmark
Phone: +45 7488 2222

**Danfoss
Power Solutions Trading
(Shanghai) Co., Ltd.**
Building #22, No. 1000 Jin Hai Rd
Jin Qiao, Pudong New District
Shanghai, China 201206
Phone: +86 21 3418 5200

Danfoss can accept no responsibility for possible errors in catalogues, brochures and other printed material. Danfoss reserves the right to alter its products without notice. This also applies to products already on order provided that such alterations can be made without changes being necessary in specifications already agreed. All trademarks in this material are property of the respective companies. Danfoss and the Danfoss logotype are trademarks of Danfoss A/S. All rights reserved.