

Axial piston variable pump A10VO series 52 and 53



- ▶ For machines with medium pressure requirements
- ▶ Sizes 10 to 100
- ▶ Nominal pressure 250 bar (3600 psi)
- ▶ Maximum pressure 315 bar (4550 psi)
- ▶ Open circuit

Features

- ▶ Variable pump with axial piston rotary group in swashplate design for hydrostatic drives in open circuit.
- ▶ Flow is proportional to drive speed and displacement.
- ▶ The flow can be infinitely varied by adjusting the swashplate angle.
- ▶ Stable bearing for long service life
- ▶ High permissible drive speed
- ▶ Favorable power-to-weight ratio – compact dimensions
- ▶ Low noise
- ▶ Excellent suction characteristics
- ▶ Electrohydraulic pressure control
- ▶ Power control
- ▶ Electro proportional swivel angle control
- ▶ Short control times

Contents

Type code series 52 and 53	2
Hydraulic fluids	7
Working pressure range	9
Technical data	10
DR – Pressure controller	14
DRG – Pressure controller, remotely controlled	15
DRF (DFR) / DRS (DFR1) / DRSC	16
LA... – Pressure, flow and power controller	18
LA... – Variations	19
ED – Electrohydraulic pressure control	20
ER – Electrohydraulic pressure control	22
EP – Electro proportional control	23
EK – Electro proportional control with controller cut-off	24
EP(K).DF / EP(K).DS / EP(K)	25
EP.ED / EK.ED	26
EC4 – Electro-hydraulic control valve	27
Dimensions, size 10 to 100	29
Dimensions, through drive	72
Overview of mounting options	76
Combination pumps A10VO + A10VO	77
Connector for solenoids	78
Swivel angle sensor	79
Installation instructions	80
Project planning notes	84
Safety instructions	85
Related documentation	86

Type code series 52

01	02	03	04	05	06	07	08	09	10	11	12
A10V	O			/	52	-	V				

Axial piston unit										10	28	45	60	85	
01	Swashplate design, variable, nominal pressure 250 bar (3600 psi), maximum pressure 315 bar (4550 psi)									●	●	●	●	●	A10V

Operating mode												
02	Pump, open circuit											O

Size (NG)														
03	Geometric displacement, see table of values on page 10									10	28	45	60	85

Control device												
04	Pressure controller	Hydraulic				●	●	▲ ³⁾	●	●	DR	
	With flow controller	Hydraulic	X-T open			●	●	▲ ³⁾	●	●	DFR	
			X-T plugged	With flushing function			●	●	▲ ³⁾	●	●	DFR1
				Without flushing function			-	●	▲ ³⁾	●	●	DRSC
	With pressure cut-off	Hydraulic	Remote controlled				●	●	●	●	●	DRG
			Electric	Negative control	$U = 12\text{ V}$			-	●	●	●	●
	$U = 24\text{ V}$					-	●	●	●	●	ED72	
	Electric	Positive control	$U = 12\text{ V}$			-	●	●	●	●	ER71	
			$U = 24\text{ V}$			-	●	●	●	●	ER72	
	Electro-hydraulic control valve		Positive control	$U = 12\text{ V to }24\text{ V}$			-	●	-	-	-	EC4
Negative control						-	○	-	-	-	EB4	

Series										10	28	45	60	85	
05	Series 5, index 2									●	●	●	●	●	52

Direction of rotation										10	28	45	60	85
06	Viewed on drive shaft	Clockwise				●	●	●	●	●	R			
		Counter-clockwise				●	●	●	●	●	L			

Sealing material										10	28	45	60	85	
07	FKM (fluorocarbon rubber)									●	●	●	●	●	V

Drive shaft										10	28	45	60	85
08	Splined shaft ISO 3019-1	Standard shaft				●	●	●	●	●	S			
		Similar to shaft "S" however for higher torque				-	●	●	●	●	R			
		Reduced diameter, limited suitability for through drive				●	●	●	●	●	U			
	Like shaft "U" but for higher torque, only conditionally suitable for mounting with through-drive.				-	●	●	●	●	W				
	For mounting options, see page 76													
	Parallel keyed shaft DIN 6885 not for through-drive				● ¹⁾	-	-	-	-	P				
Parallel keyed shaft ISO 3019-1 not for through-drive				● ²⁾	●	●	●	●	K					
Tapered keyed shaft and UNF threaded bolt not for through-drive				-	●	●	●	●	C					

Mounting flange											
09	Based on ISO 3019-2 (ISO)	2-hole		●	-	-	-	-	-	A	
		2-hole		●	●	●	●	●	●	C	
		4-hole		-	-	-	●	-	-	D	

● = Available ○ = On request - = Not available ▲ = Not for new projects

¹⁾ With mounting flange A and C; order item 09 and port plate 14
²⁾ Only with mounting flange C; order item 09 and port plate 64

³⁾ Use data sheet 92706 for pressure flow controller DR, DFR, DFR1, DRSC A10VO 45 series 60.

01	02	03	04	05	06	07	08	09	10	11	12
A10V	O			/	52		-	V			

Working port				10	28	45	60	85	
10	SAE flange ports according to ISO 6162 metric	Fastening thread metric rear	Not for through drive	-	●	●	●	●	11
		Fastening thread metric laterally opposite	For through drive	-	●	●	●	●	12
		Fastening thread metric laterally offset 90°	Not for through drive; available for counter-clockwise rotation only	-	-	●	-	-	13
	Threaded port metric	Rear	Not for through drive	● ²⁾	-	-	-	-	14
	SAE flange ports according to ISO 6162 UNC	Fastening thread UNC rear	Not for through drive	-	●	●	●	●	61
		Fastening thread UNC laterally opposite	For through drive	-	●	●	●	●	62
Threaded port UNC	rear	Not for through drive	● ³⁾	●	●	-	-	64	

Through drive (for mounting options, see page 76)

				10	28	45	60	85		
11	Flange ISO 3019-1	Hub for splined shaft ¹⁾								
	Diameter	Diameter								
	Without through drive			●	●	●	●	●	N00	
	82-2 (A)	5/8 in	9T 16/32DP		-	●	●	●	●	K01
		3/4 in	11T 16/32DP		-	●	●	●	●	K52
	101-2 (B)	7/8 in	13T 16/32DP		-	●	●	●	●	K68
		1 in	15T 16/32DP		-	-	●	●	●	K04
	127-4 (C)	1 1/4 in	14T 12/24DP		-	-	-	●	●	K15
		1 1/2 in	17T 12/24DP		-	-	-	-	●	K16
	127-2 (C)	1 1/4 in	14T12/24DP		-	-	-	-	●	K07
1 1/2 in		17T 12/24DP		-	-	-	-	●	K24	

Connector for solenoids				10	28	45	60	85	
12	Without connector (without solenoid, only for hydraulic controls, without signs)			●	●	●	●	●	
	DEUTSCH – molded connector, 2-pin – without suppressor diode (for electric controls)			-	●	●	●	●	P

Swivel angle sensor				10	28	45	60	85	
13	Without swivel angle sensor (without code)			●	●	●	●	●	
	With electric swivel angle sensor PAL (as per data sheet 95161) ⁴⁾	Ratiometric	Power supply U = 5V DC	-	○	○	-	-	H
		SENT/SENT		-	○	○	-	-	P

● = Available ○ = On request - = Not available

Notice

- ▶ Observe the general project planning notes on page 84 and the project planning notes regarding each control device.
- ▶ In addition to the type code, please specify the relevant technical data.

1) In accordance with ANSI B92.1a
 2) Only with mounting flange A; order item 09
 3) Only with mounting flange C; order item 09
 4) Also see page 79 for further details

01	02	03	04	05	06	07	08	09	10	11	12
A10V	O			/	53	-	V				

04	Electro proportional control		Positive control		18	28	45	63	72	85	100		
	With pressure control				<i>U</i> = 12 V	●	●	●	●	●	●	●	EP1D
					<i>U</i> = 24 V	●	●	●	●	●	●	●	●
	With pressure and flow control (load-sensing)		X-T open		<i>U</i> = 12 V	●	●	●	●	●	●	●	EP1DF
					<i>U</i> = 24 V	●	●	●	●	●	●	●	●
	With pressure and flow control (load-sensing)		X-T plugged		<i>U</i> = 12 V	●	●	●	●	●	●	●	EP1DS
					<i>U</i> = 24 V	●	●	●	●	●	●	●	●
	With electrohydraulic pressure control				<i>U</i> = 12 V	●	●	●	●	●	●	●	EP1ED
					<i>U</i> = 24 V	●	●	●	●	●	●	●	●
	Electro proportional control		Positive control										
	With pressure control				<i>U</i> = 12 V	●	●	○	●	●	●	●	EK1D
					<i>U</i> = 24 V	●	●	○	●	●	●	●	●
	Pressure and flow control with controller cut-off (load sensing)		X-T open		<i>U</i> = 12 V	●	●	○	●	●	●	●	EK1DF
					<i>U</i> = 24 V	●	●	○	●	●	●	●	●
	Pressure and flow control with controller cut-off (load sensing)		X-T plugged		<i>U</i> = 12 V	●	●	○	●	●	●	●	EK1DS
					<i>U</i> = 24 V	●	●	○	●	●	●	●	●
	Electrohydraulic pressure control with controller cut-off				<i>U</i> = 12 V	●	●	○	●	●	●	●	EK1ED
					<i>U</i> = 24 V	●	●	○	●	●	●	●	●

Series					18	28	45	63	72	85	100	
05	Series 5, index 3				●	●	●	●	●	●	●	53

Direction of rotation					18	28	45	63	72	85	100	
06	Viewed on drive shaft		Clockwise		●	●	●	●	●	●	●	R
			Counter-clockwise		●	●	●	●	●	●	●	L

Sealing material					18	28	45	63	72	85	100	
07	FKM (fluorocarbon rubber)				●	●	●	●	●	●	●	V

Drive shaft					18	28	45	63	72	85	100	
08	Splined shaft		Standard shaft		●	●	●	●	●	●	●	S
	ISO3019-1		Similar to shaft "S" however for higher torque		●	●	●	●	●	●	●	R
			Reduced diameter, limited suitability for through drive		●	●	●	●	●	●	●	U
			Like shaft "U" but for higher torque, only conditionally suitable for mounting with through-drive. For mounting options, see page 76		-	●	●	●	●	●	●	W
			Parallel keyed shaft ISO 3019-1 not for through-drive		●	●	●	●	●	●	●	K

Mounting flange					18	28	45	63	72	85	100	
09	Based on ISO 3019-1 (SAE)		2-hole		●	●	●	●	●	●	●	C
			4-hole		-	-	-	●	●	●	●	D

● = Available ○ = On request - = Not available

01	02	03	04	05	06	07	08	09	10	11	12
A10V	O			/	53		-	V			

Working port				18	28	45	63	72	85	100	
10	SAE flange ports according to ISO 6162 metric	Fastening thread metric rear	Not for through drive	●	●	●	●	●	●	●	11
		Fastening thread metric laterally opposite	For through drive	●	●	●	●	●	●	●	12
		Fastening thread metric laterally offset 90°	Not for through drive; available for counter-clockwise rotation only	-	-	●	-	-	-	-	-
SAE flange ports according to ISO 6162 UNC	Fastening thread UNC rear	Not for through drive	●	●	●	●	●	●	●	●	61
	Fastening thread UNC laterally opposite	For through drive	●	●	●	●	●	●	●	●	62

Through drive (for mounting options, see page 76)

11	Flange ISO 3019-1	Hub for splined shaft ¹⁾								
	Diameter	Diameter	18	28	45	63	72	85	100	
	Without through drive		●	●	●	●	●	●	●	N00
82-2 (A)	5/8 in	9T 16/32DP	●	●	●	●	●	●	●	K01
	3/4 in	11T 16/32DP	●	●	●	●	●	●	●	K52
101-2 (B)	7/8 in	13T 16/32DP	-	●	●	●	●	●	●	K68
	1 in	15T 16/32DP	-	-	●	●	●	●	●	K04
127-4 (C)	1 1/4 in	14T 12/24DP	-	-	-	●	●	●	●	K15
	1 1/2 in	17T 12/24DP	-	-	-	-	-	●	●	K16
127-2 (C)	1 1/4 in	14T12/24DP	-	-	-	-	-	●	●	K07
	1 1/2 in	17T 12/24DP	-	-	-	-	-	●	●	K24

Connector for solenoids			18	28	45	63	72	85	100	
12	Without connector (without solenoid, only for hydraulic controls, without signs)		●	●	●	●	●	●	●	
	DEUTSCH – molded connector, 2-pin – without suppressor diode (for electric controls)		●	●	●	●	●	●	●	P

Swivel angle sensor				18	28	45	63	72	85	100	
13	Without swivel angle sensor (without code)			●	●	●	●	●	●	●	
	With electric swivel angle sensor PAL (as per data sheet 95161) ³⁾	Ratiometric	Power supply U = 5V DC	-	-	-	● ²⁾	● ²⁾	-	-	H
		SENT/SENT		-	-	-	○ ²⁾	○ ²⁾	-	-	P

● = Available ○ = On request - = Not available

Notice

- ▶ Note the project planning notes on page 84.
- ▶ In addition to the type code, please specify the relevant technical data when placing your order.

1) In accordance with ANSI B92.1a
2) Only available with mounting flange C (order item 09)
3) Also see page 79 for further details

Hydraulic fluids

The A10VO variable pump is designed for operation with HLP mineral oil according to DIN 51524.

Application instructions and requirements for hydraulic fluid selection, behavior during operation as well as disposal and environmental protection should be taken from the following data sheets before the start of project planning:

- ▶ 90220: Hydraulic fluids based on mineral oils and related hydrocarbons
- ▶ 90221: Environmentally acceptable hydraulic fluids

Selection of hydraulic fluid

Bosch Rexroth evaluates hydraulic fluids on the basis of the Fluid Rating according to the technical data sheet 90235.

Hydraulic fluids with positive evaluation in the Fluid Rating are provided in the following technical data sheet:

- ▶ 90245: Bosch Rexroth Fluid Rating List for Rexroth hydraulic components (pumps and motors)

Selection of hydraulic fluid shall make sure that the operating viscosity in the operating temperature range is within the optimum range (v_{opt} ; see selection diagram).

Viscosity and temperature of hydraulic fluids

	Viscosity	Shaft seal	Temperature ²⁾	Comment
Cold start	$v_{max} \leq 1600 \text{ mm}^2/\text{s}$ (cSt)	FKM	$\vartheta_{St} \geq -25 \text{ }^\circ\text{C}$ (-13 °F)	$t \leq 3 \text{ min}$, without load ($p \leq 50 \text{ bar}$ (725 psi)), $n \leq 1000 \text{ rpm}$ Permissible temperature difference between the axial piston unit and hydraulic fluid in the system max. 25 K (45 °F)
Warm-up phase	$v = 1600 \dots 400 \text{ mm}^2/\text{s}$ (cSt)			$t \leq 15 \text{ min}$, $p \leq 0.7 \times p_{nom}$ und $n \leq 0.5 \times n_{nom}$
Permissible operating range	$v = 400 \dots 10 \text{ mm}^2/\text{s}$ (cSt) ¹⁾	FKM	$\vartheta \leq +110 \text{ }^\circ\text{C}$ (+230 °F)	Measured at port L_x
	$v_{opt} = 36 \dots 16 \text{ mm}^2/\text{s}$ (cSt)			Optimal operating viscosity and efficiency range
Short-term operation	$v_{min} = 10 \dots 7 \text{ mm}^2/\text{s}$ (cSt)	FKM		$t \leq 3 \text{ min}$, $p \leq 0.3 \times p_{nom}$, measured at port L_x

▼ Selection diagram

Maximum permissible viscosity on cold start

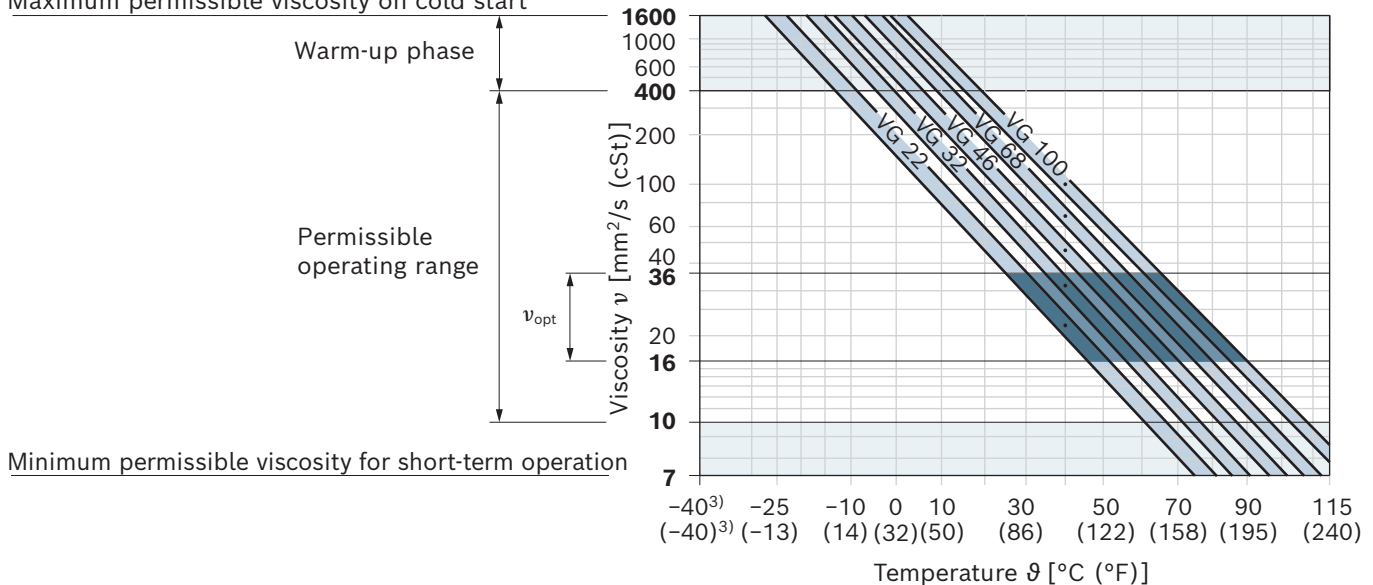

1) This corresponds, e.g. with the VG 46, to a temperature range of +4 °C to +85 °C (+39 °F to +113 °F) (see selection diagram)

2) If the temperature at extreme operating parameters cannot be adhered to, please contact us.

3) For applications in the low-temperature range, please contact us.

Filtration of the hydraulic fluid

Finer filtration improves the cleanliness level of the hydraulic fluid, which increases the service life of the axial piston unit.

A cleanliness level of at least 20/18/15 is to be maintained according to ISO 4406

At a hydraulic fluid viscosity of less than 10 mm²/s (cSt) (e.g., due to high temperatures during short-term operation) at the drain port, a cleanliness level of at least 19/17/14 acc. to ISO 4406 is required.

Examples of hydraulic fluid temperatures at a viscosity of 10 mm²/s (cSt):

- ▶ 73 °C (163 °F) at HLP 32
- ▶ 85 °C (185 °F) at HLP 46

Working pressure range

Pressure at working port B			Definition
Nominal pressure p_{nom}	250 bar (3600 psi)		The nominal pressure corresponds to the maximum design pressure.
Maximum pressure p_{max}	315 bar (4550 psi)		The maximum pressure corresponds to the maximum working pressure within a single operating period. The sum of single operating periods must not exceed the total operating period.
Single operating period	2.5 ms		
Total operating period	300 h		
Minimum pressure $p_{B absolute}$ (high-pressure side)	10 bar (145 psi)		Minimum pressure on the high-pressure side (B) which is required in order to prevent damage to the axial piston unit.
Rate of pressure change $R_{A max}$	16000 bar/s (232000psi/s)		Maximum permissible speed of pressure build-up and reduction during a pressure change across the entire pressure range.
Pressure at suction port S (inlet)			
Minimum pressure $p_{S min}$	Standard 0.8 bar (12 psi) absolute		Minimum pressure at suction port S (inlet) which is required to prevent damage to the axial piston unit. The minimum pressure depends on the rotational speed and displacement of the axial piston unit.
Maximum pressure $p_{S max}$	5 bar (75 psi) absolute		
Case pressure at port L, L ₁ , L ₂			
Maximum pressure $p_{L max}$	2 bar (30 psi)		Maximum 0.5 bar (7.5 psi) higher than inlet pressure at port S, but not higher than $p_{L max}$. The case pressure must always exceed the ambient pressure. A drain line to the reservoir is required.
Pilot pressure port X with external high pressure			
Maximum pressure p_{max}	315 bar (4550 psi)		For the design of all control lines pressurized with external high pressure, the values for the rate of pressure change, maximum single operating period and total operating period applicable to port B must not be exceeded.

Notice

Working pressure range applies when using hydraulic fluids based on mineral oils. Please contact us for values for other hydraulic fluids.

▼ Pressure definition

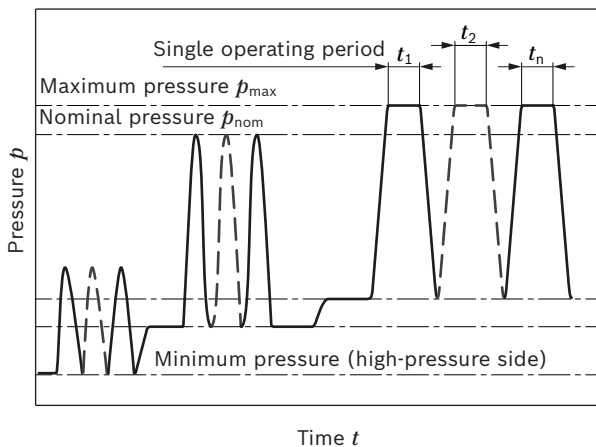

$$\text{Total operating period} = t_1 + t_2 + \dots + t_n$$

▼ Rate of pressure change $R_{A max}$

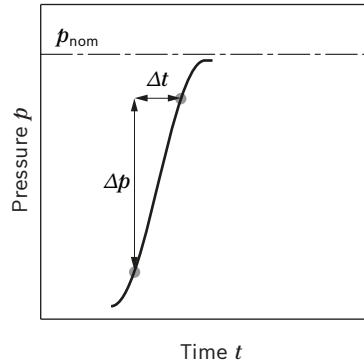

Technical data

Size	NG		10	18	28	45	60	63	72	85	100	
Geometric displacement, per revolution	$V_{g \max}$	cm ³	10.5	18	28	45	60	63	72	85	100	
		inch ³	0.64	1.10	1.75	2.75	3.66	3.84	4.39	5.18	6.10	
Maximum rotational speed ¹⁾	at $V_{g \max}$	n_{nom}	rpm	3600	3300	3000	2600 ⁵⁾	2700	2600	2600	2500	2300
	at $V_g < V_{g \max}$ ²⁾	$n_{\text{max perm}}$	rpm	4320	3960	3600	3120	3140	3140	3140	3000	2500
Flow	at n_{nom} and $V_{g \max}$	q_v	l/min	37	59	84	117	162	163	187	212	230
			gpm	9.7	15.6	22	31	42	43	49.4	55	60
	at $n_E = 1500$ rpm	q_{VE}	l/min	15	27	42	68	90	95	108	128	150
			gpm	4	7.1	11.1	18	24	25.1	28.5	34	39
Power	at n_{nom} , $V_{g \max}$ and $\Delta p = 250$ bar (3600 psi)	P	kW	16	25	35	49	65	68	77	89	96
			HP	22	34	47	65	88	90	103	119	130
	at $n_E = 1500$ rpm	P_E	kW	7	11	18	28	37	39	45	53	62
			HP	9.4	15	24	38	50	52	60	71	84
Torque	at $V_{g \max}$ and $\Delta p = 250$ bar (3600 psi)	M	Nm	42	71	111	179	238	250	286	338	398
			lb-ft	31	52	82	132	175	184	211	247	293
	at $V_{g \max}$ and $\Delta p = 100$ bar (1450 psi)	M	Nm	17	29	45	72	95	100	114	135	159
			lb-ft	13	21	33	53	70	74	84	102	117
Rotary stiffness of drive shaft	S	c	kNm/rad	9.2	11.0	22.3	37.5	65.5	65.5	65.5	143.0	143.0
			lb-ft/rad	6760	8082	16400	27560	48100	48100	48100	105100	105100
	R	c	kNm/rad	–	14800	26300	41000	69400	69400	69400	152900	152900
			lb-ft/rad	–	10870	19400	30240	51200	51200	51200	112773	112773
	U	c	kNm/rad	6.8	8.0	16.7	30.0	49.2	49.2	49.2	102.9	102.9
			lb-ft/rad	5020	5870	12317	22130	36290	36290	36290	75900	75900
	W	c	kNm/rad	–	–	19.9	34.4	54.0	54.0	54.0	117.9	117.9
			lb-ft/rad	–	–	14678	25270	39830	39830	39830	86960	86960
	P	c	kNm/rad	10.7	–	–	–	–	–	–	–	–
			lb-ft/rad	7892	–	–	–	–	–	–	–	–
	K	c	kNm/rad	10.8	13.3	26.8	43.9	73.9	73.9	73.9	163.4	163.4
			lb-ft/rad	7965	9810	19770	32380	54506	54506	54506	120518	120518
	C	c	kNm/rad	–	–	4)	4)	4)	–	–	4)	–
			lb-ft/rad	–	–	4)	4)	4)	–	–	4)	–
Moment of inertia of the rotary group	J_{TW}	kgm ²	0.0006	0.0009	0.0017	0.003	0.0056	0.0056	0.0056	0,012	0,012	
		lb-ft ²	0.0142	0.2207	0.0403	0.0783	0.1329	0.1329	0.1329	0.2848	0.2848	
Maximum angular acceleration ³⁾	α	rad/s ²	8000	6800	5500	4000	3300	3300	3300	2700	2700	
Case volume	V	l	0.2	0.25	0.3	0.5	0.8	0.8	0.8	1	1	
		gal	0.05	0.06	0.08	0.13	0.21	0.21	0.21	0.26	0.26	
Weight without through drive (approx.)	m	kg	8	11.5	15	18	22	22	22	36	36	
		lbs	17	25	33	40	48.5	48.5	48.5	79	79	
Weight with through drive (approx.)	m	kg	–	13	18	24	28	28	28	45	45	
		lbs	–	28.6	40	53	62	62	62	99	99	

1) The values are applicable:
 – at absolute pressure $p_{\text{abs}} = 1$ bar (15 psi) at suction port **S**
 – for the optimum viscosity range from $v_{\text{opt}} = 36$ to 16 mm²/s (cSt)
 – with hydraulic fluid based on mineral oils

2) See diagram on page 11 at speed increase up to $n_{\text{max adm}}$.

3) The data are valid for values between the minimum required and maximum permissible rotational speed. Valid for external excitation (e.g. diesel engine 2 to 8 times the rotary frequency; cardan shaft 2 times the rotary frequency). The limit value is only valid for a single pump. The load capacity of the connection parts must be considered.

4) On request

5) Higher rotational speeds on request.

Determination of the characteristics		
Flow	$q_v = \frac{V_g \times n \times \eta_v}{1000}$	[l/min]
Torque	$M = \frac{V_g \times \Delta p}{20 \times \pi \times \eta_{hm}}$	[Nm]
Power	$P = \frac{2 \pi \times M \times n}{60000} = \frac{q_v \times \Delta p}{600 \times \eta_t}$	[kW]
Determination of the characteristics		
Flow	$q_v = \frac{V_g \times n \times \eta_v}{231}$	[gpm]
Torque	$M = \frac{V_g \times \Delta p}{24 \times \pi \times \eta_{hm}}$	[lb-ft]
Power	$P = \frac{2 \pi \times M \times n}{33000} = \frac{q_v \times \Delta p}{1714 \times \eta_t}$	[HP]

Key

- V_g Displacement per revolution [cm³ (inch³)]
- Δp Differential pressure [bar (psi)]
- n Rotational speed [rpm]
- η_v Volumetric efficiency
- η_{hm} Hydraulic-mechanical efficiency
- η_t Total efficiency ($\eta_t = \eta_v \times \eta_{hm}$)

Notice

- ▶ Theoretical values, without efficiency and tolerances; values rounded
- ▶ Operation above the maximum values or below the minimum values may result in a loss of function, a reduced service life or in the destruction of the axial piston unit. Bosch Rexroth recommends checking the loading by means of test or calculation / simulation and comparison with the permissible values.

▼ **Maximum permissible rotational speed (speed limit)**
 Permissible rotational speed by increasing inlet pressure $p_{absolute}$ at suction opening **S** or at $V_g \leq V_{gmax}$

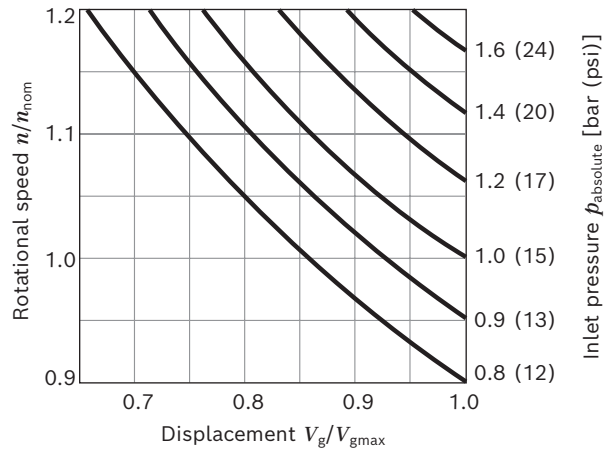

Permissible radial and axial loading of the drive shaft

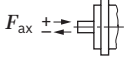
Size		NG	10	18	28	45	60/63	72	85	100	
Maximum radial force at a/2		$F_{q \max}$	N	250	350	1200	1500	1700	1500	2000	2000
			lbf	56	78	270	337	382	337	450	450
Maximum axial force		$\pm F_{ax \max}$	N	400	700	1000	1500	2000	1500	3000	3000
			lbf	90	157	225	337	450	337	675	675

Notice

- The values given are maximum values and do not apply to continuous operation. All loads of the drive shaft reduce the bearing service life.

Permissible input and through-drive torques

Size			10	18	28	45	60/63	72	85	100
Torque at $V_{g \max}$ and $\Delta p = 250 \text{ bar (3600 psi)}^1$	M_{\max}	Nm	42	71	111	179	250	321	338	398
		lb-ft	31	52	82	132	184	211	247	293
Max. input torque on drive shaft ²⁾										
S	$M_{E \max}$	Nm	126	124	198	319	630	630	1157	1157
		lb-ft	93	91	146	235	464	464	853	853
	\emptyset	in	3/4	3/4	7/8	1	1 1/4	1 1/4	1 1/2	1 1/2
R	$M_{E \max}$	Nm	–	160	250	400	650	650	1215	1215
		lb-ft	–	118	184	295	479	479	895	895
	\emptyset	in	–	3/4	7/8	1	1 1/4	1 1/4	1 1/2	1 1/2
U	$M_{E \max}$	Nm	60	59	105	188	306	306	628	628
		lb-ft	44	43	77	139	226	226	463	463
	\emptyset	in	5/8	5/8	3/4	7/8	1	1	1 1/4	1 1/4
W	$M_{E \max}$	Nm	–	–	140	220	396	383	650	650
		lb-ft	–	–	103	162	292	282	479	479
	\emptyset	in	–	–	3/4	7/8	1	1	1 1/4	1 1/4
P	$M_{E \max}$	Nm	90	–	–	–	–	–	–	–
		lb-ft	66	–	–	–	–	–	–	–
	\emptyset	mm	18	–	–	–	–	–	–	–
		in	0.71	–	–	–	–	–	–	–
K	$M_{E \max}$	Nm	106	104	145	212	441	441	750	750
		lb-ft	78	76	107	156	325	325	553	553
	\emptyset	in	3/4	3/4	7/8	1	1 1/4	1 1/4	1 1/2	1 1/2
C	$M_{E \max}$	Nm	–	–	145	212	441	–	750	–
		lb-ft	–	–	107	156	325	–	553	–
Maximum through-drive torque										
S	$M_{D \max}$	Nm	–	108	160	319	484	484	698	698
		lb-ft	–	80	118	235	357	357	515	515
R	$M_{D \max}$	Nm	–	120	176	365	484	484	698	–
		lb-ft	–	89	130	270	357	357	515	–
U	$M_{D \max}$	Nm	–	59	105	188	306	306	628	628
		lb-ft	–	43	77	139	226	226	463	463
W	$M_{D \max}$	Nm	–	–	140	220	396	383	650	650
		lb-ft	–	–	103	162	292	282	479	479
K	$M_{D \max}$	Nm	–	104	145	212	441	441	–	750
		lb-ft	–	76	107	156	325	325	–	553

1) Efficiency not considered

2) For drive shafts with no radial force

▼ **Distribution of torques**

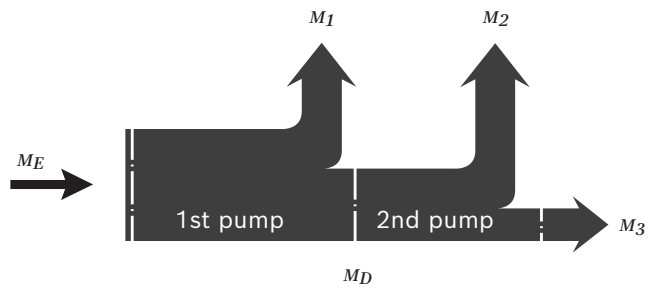

Torque at 1st pump	M_1
Torque at 2nd pump	M_2
Torque at 3rd pump	M_3
Input torque	$M_E = M_1 + M_2 + M_3$
	$M_E < M_{E \max}$
Through-drive torque	$M_D = M_2 + M_3$
	$M_D < M_{D \max}$

DR – Pressure controller

The pressure controller limits the maximum pressure at the pump outlet within the control range of the variable pump. The variable pump only supplies as much hydraulic fluid as is required by the consumers. If the working pressure exceeds the pressure command value at the pressure valve, the pump will regulate to a smaller displacement to reduce the control differential.

- ▶ Basic position in depressurized state: $V_{g \max}$.
- ▶ Setting range¹⁾ for pressure control 35 to 250 bar (510 to 3600 psi).
Standard is 250 bar (3600 psi).

▼ Characteristic curve DR

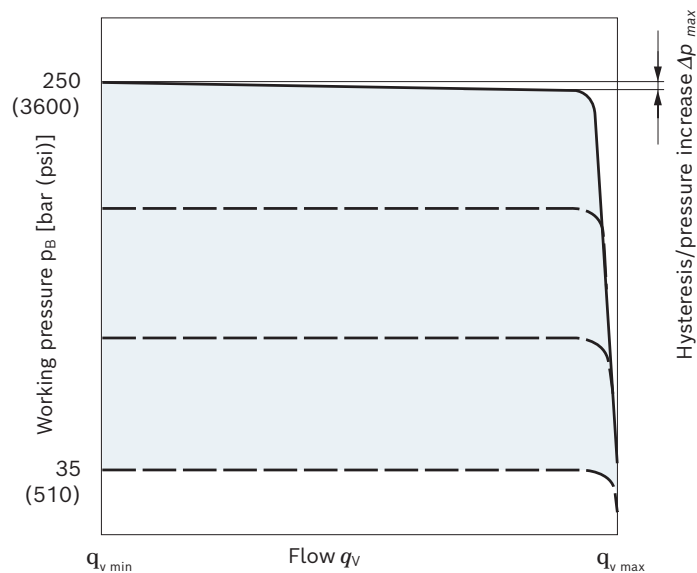

Characteristic curve valid at $n_1 = 1500$ rpm and $\vartheta_{\text{fluid}} = 50$ °C (120° F).

▼ Circuit diagram DR

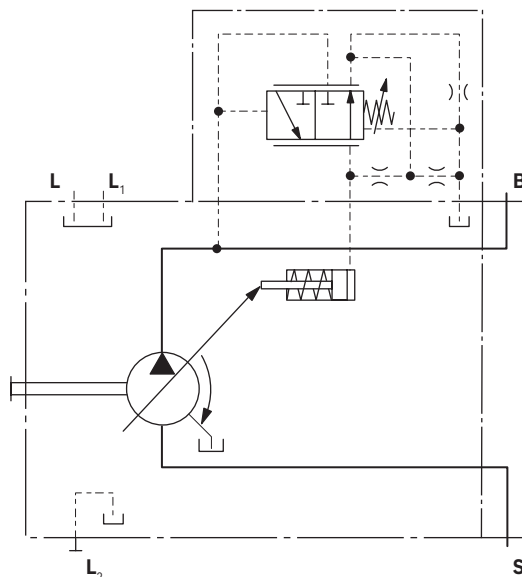

Controller data

Size		10	18	28	60	72	85	100
					63			
Pressure increase	Δp [bar]	6	6	6	8	8	12	14
	Δp [psi]	90	90	90	115	115	175	200
Hysteresis	Δp [bar]	Maximum 4						
	Δp [psi]	Maximum 60						
Pilot fluid consumption	[l/min]	Maximum approx. 3						
	[gpm]	Maximum approx. 0.8						

¹⁾ In order to prevent damage to the pump and the system, the permissible setting range must not be exceeded. The range of possible settings at the valve is higher.

DRG – Pressure controller, remotely controlled

For the remote controlled pressure controller, the LS pressure relief is performed using a separately arranged pressure relief valve. Therefore, any pressure control value under the pressure set on the pressure controller can be regulated. Pressure controller DR see page 14.

A pressure relief valve is externally piped up to port **X** for remote control. This relief valve is not included in the scope of delivery of the DRG control. When there is differential pressure of 20 bar (290 psi) Δp , the quantity of control fluid at the port is **X** approx. 1.5 l/min (0.4 gpm). If another setting is required (range from 14 to 22 bar (200 to 320 psi)) please state in plain text.

As a separate pressure relief valve (1) we recommend:

- ▶ A direct operated, hydraulic or electric proportional one, suitable for the control fluid quantity mentioned above.

The maximum line length should not exceed 2 m (6.6 ft).

- ▶ Basic position in depressurized state: $V_{g \max}$
- ▶ Setting range¹⁾ for pressure control 35 to 250 bar (510 to 3600 psi) (3). Standard is 250 bar (3600 psi).
- ▶ Setting range for differential pressure 14 to 22 bar (200 to 320 psi) (2). Standard is 20 bar (290 psi).

Unloading port **X** to the reservoir results in a zero stroke pressure (standby) which is approx. 1 to 2 bar (15 to 30 psi) higher than the defined differential pressure Δp , however system influences are not taken into account.

▼ Characteristic curve DRG

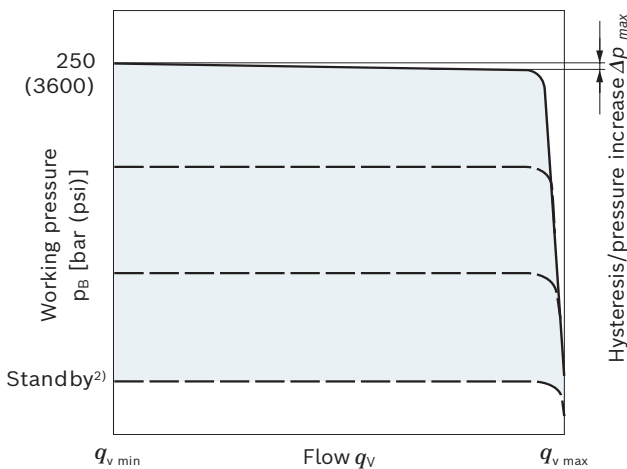

Characteristic curve valid at $n_1 = 1500$ rpm and $\vartheta_{\text{fluid}} = 50$ °C (120 °F).

▼ Circuit diagram DRG

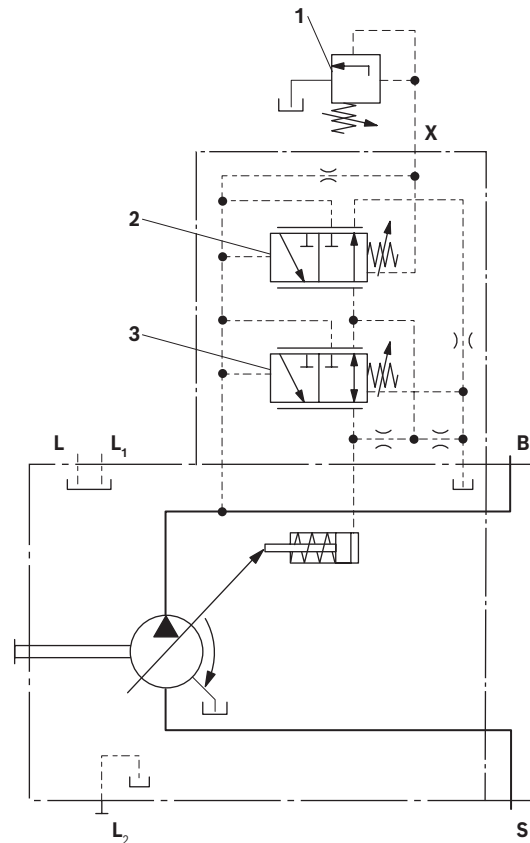

- 1 The separate pressure relief valve and the line are not included in the scope of delivery.
- 2 Remote controlled pressure cut-off (G).
- 3 Pressure controller (DR)

Controller data

Size	10	18	28	45	60	72	85	100	
	63								
Pressure increase	Δp [bar]	6	6	6	6	8	8	12	14
	Δp [psi]	87	87	87	87	115	115	175	200
Hysteresis	Δp [bar]	Maximum 4							
	Δp [psi]	Maximum 60							
Pilot fluid consumption	[l/min]	Maximum approx. 3							
	[gpm]	Maximum approx. 0.8							

- 1) In order to prevent damage to the pump and the system, the permissible setting range must not be exceeded. The range of possible settings at the valve is higher.
- 2) Zero stroke pressure from pressure setting Δp on controller (2)

DRF (DFR) / DRS (DFR1) / DRSC- pressure flow controller

In addition to the pressure controller function (see page 14), an adjustable orifice (e.g. directional valve) is used to adjust the differential pressure upstream and downstream of the orifice. This is used to control the pump flow. The pump flow is equal to the actual hydraulic fluid quantity required by the consumer. With all controller combinations, the V_g reduction has priority.

- ▶ Basic position in depressurized state: $V_{g \max}$.
- ▶ Setting range¹⁾ to 250 bar (3600 psi).
- ▶ DR pressure controller data see page 14

▼ Characteristic curve DRF (DFR) / DRS (DFR1) / DRSC

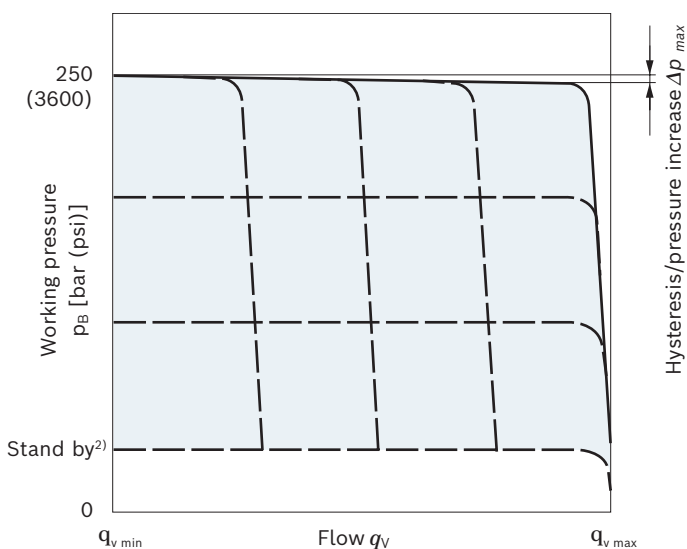

▼ Characteristic curve at variable rotational speed

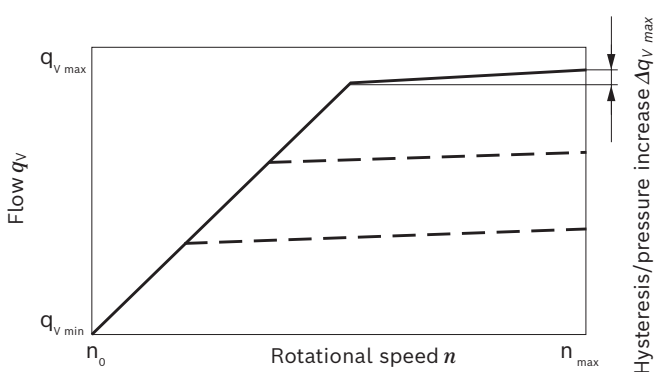

Characteristic curves valid at $n_1 = 1500$ rpm and $\vartheta_{\text{fluid}} = 50$ °C (120 °F).

- 1) In order to prevent damage to the pump and the system, the permissible setting range must not be exceeded. The range of possible settings at the valve is higher.
- 2) Zero stroke pressure from differential pressure setting Δp on controller (2)

Possible connections at port **B** (not included in the scope of delivery)

LS mobile control blocks	Data sheets
M4-12	64276
M4-15	64283
LUDV mobile control blocks	
M7-22	64295

▼ Circuit diagram DRF (DFR)

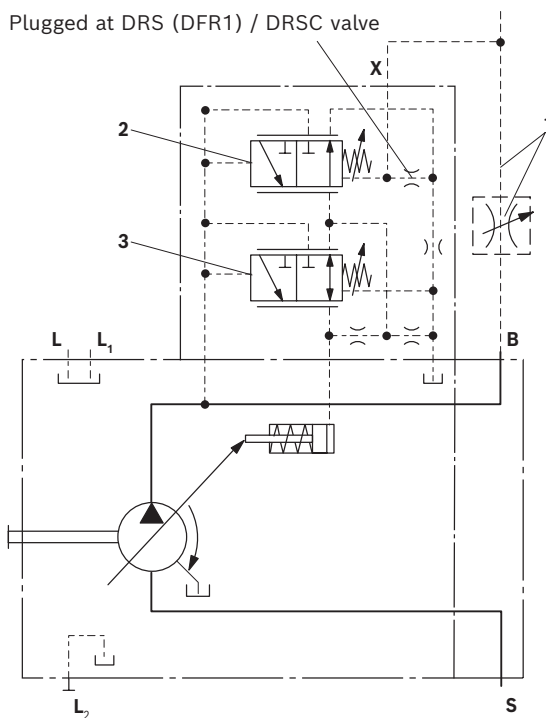

- 1 The metering orifice (control block) and the line is not included in the scope of delivery.
- 2 Flow controller (FR).
- 3 Pressure controller (DR)

Notice

The DRS (DFR1) and DRSC versions have no unloading from **X** to the reservoir.

The LS must thus be unloaded in the system.

Because of the flushing function sufficient unloading of the flow controller in DRS (DFR1) control valve **X**-line must also be provided.

If this unloading of the **X** line cannot be ensured, the DRF control valve must be used.

For further information see page 17

Differential pressure Δp :

- ▶ Standard setting: 14 bar (200 psi) If another setting is required, please state in clear text.
- ▶ Setting range: 14 bar to 22 bar (200 to 320 psi)

Unloading port **X** to the reservoir results in a zero stroke pressure (standby) which is approx. 1 to 2 bar (15 to 30 psi) higher than the defined differential pressure Δp , however system influences are not taken into account.

Controller data

- ▶ DR pressure controller data, see page 14.
- ▶ Maximum flow deviation measured at drive speed
 $n = 1500$ rpm.

Size		10	18	28	60 63	72	85	100
Flow deviation	Δq_{vmax} [l/min]	0.5	0.9	1.0	2.5	2.5	3.1	3.1
	Δq_{vmax} [gpm]	0.13	0.24	0.26	0.66	0.66	0.83	0.83
Hysteresis	Δp [bar]	Maximum 4						
	Δp [psi]	Maximum 60						
Pilot fluid consumption	[l/min]	Maximum approx. 3 to 4.5 (DRF (DFR)) Maximum approx. 3 ((DFR1) / DRSC)						
	[gpm]	Maximum approx. 0.8 to 1.2 (DRF (DFR)) Maximum approx. 0.8 (DRSC)						

LA... – Pressure, flow and power controller

Pressure controller equipped as DR(G), see page 14 (15). Equipment of the flow controller like DRS (DFR1), see page 16.

In order to achieve a constant drive torque with varying working pressures, the swivel angle and with it the volume flow from the axial piston pump is varied so that the product of flow and pressure remains constant.

Flow control is possible below the power control curve.

When ordering please state the power characteristics to be set at the factory in plain text, e.g. 20 kW (27 HP) at 1500 rpm.

Controller data

- ▶ Pressure controller DR see page 14.
- ▶ Pressure and flow controller DR see page 16.
- ▶ Pilot fluid consumption max. approx. 5.5 l/min (1.45 gpm).

Beginning of control [bar (psi)]	Torque M [Nm (lb-ft)] for size							Code
	18	28	45	63	72	85	100	
10 to 35 (145 to 510)	3.8 – 12.1 (2.80 – 8.92)	6 – 19 (4.4 – 14)	10 – 30 (7.4 – 22.1)	15 – 43 (11 – 32)	17 – 49.2 (12.5 – 36.3)	20 – 57 (15 – 42)	24 – 68 (18 – 49.5)	LA5
36 to 70 (520 to 1015)	12.2 – 23.3 8.92 / 17.2	19.1 – 36 (14 – 26.5)	30.1 – 59 (22.2 – 43.5)	43.1 – 83 (32 – 61)	49.3 – 94.9 (36.4 – 69.9)	57.1 – 112 (42 – 83)	68.1 – 132 (49.5 – 97.1)	LA6
71 to 105 (1030 to 1520)	23.4 – 33.7 (17.2 – 24.9)	36.1 – 52 (26.6 – 38.4)	59.1 – 84 (43.6 – 62)	83.1 – 119 (61 – 88)	95.0 – 136.0 (70 – 100.3)	112.1 – 160 (83 – 118)	132.1 – 189 (97.1 – 139.4)	LA7
106 to 140 (1535 to 2030)	33.8 – 45 (24.9 – 33.2)	52.1 – 70 (38.4 – 51.6)	84.1 – 112 (62 – 83)	119.1 – 157 (88 – 116)	136.1 – 179.4 (100.4 – 132.3)	160.1 – 212 (118 – 156)	189.1 – 249 (139.4 – 183.6)	LA8
141 – 230 (2045 to 3335)	45.1 – 74.8 (33.2 – 55.2)	70.1 – 111 (51.7 – 82.4)	112.1 – 174 (83 – 128)	157.1 – 240 (116 – 178)	179.5 – 274 (132.4 – 203)	212.1 – 255 (156 – 189)	249.1 – 263 (183.3 – 195)	LA9

Conversion of the torque values in power [kW (HP)]

$$P = \frac{M}{6.4 (3.5)} \text{ [kW (HP)]} \quad (\text{At 1500 rpm})$$

$$\text{or} \quad P = \frac{2\pi \times M \times n}{60000 (33000)} \text{ [kW (HP)]} \quad (\text{For rotational speeds see table on page 10})$$

▼ Characteristic curve LA.DS

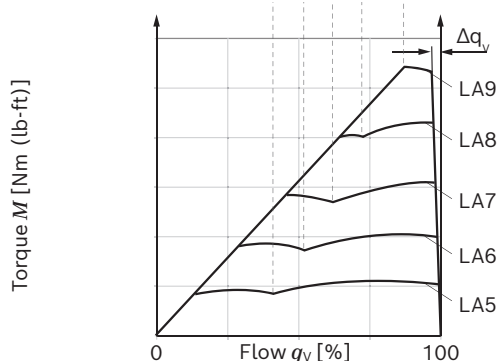
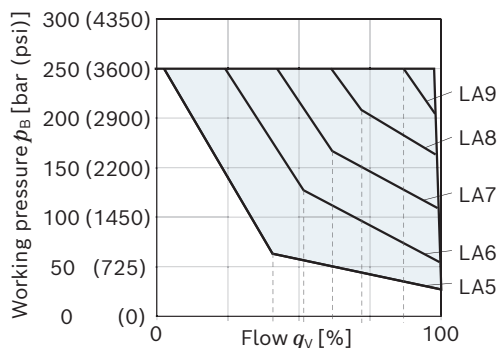

▶ Combination options with LA.. see page 19

LA... – Variations

▼ Circuit diagram LA.D with pressure cut-off

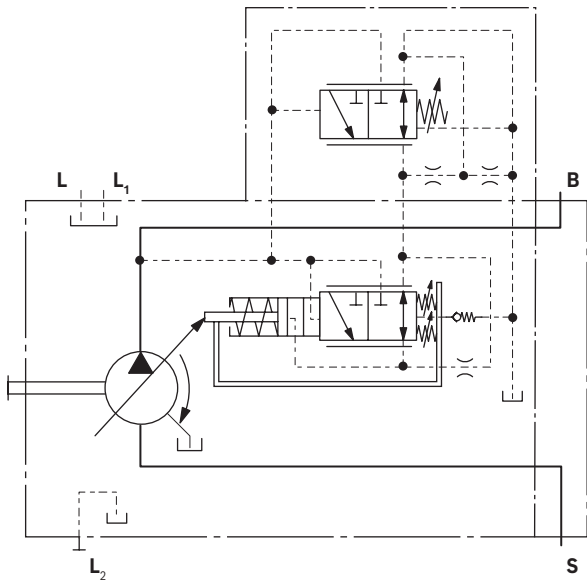

▼ Circuit diagram LA.DG with pressure cut-off, remote controlled

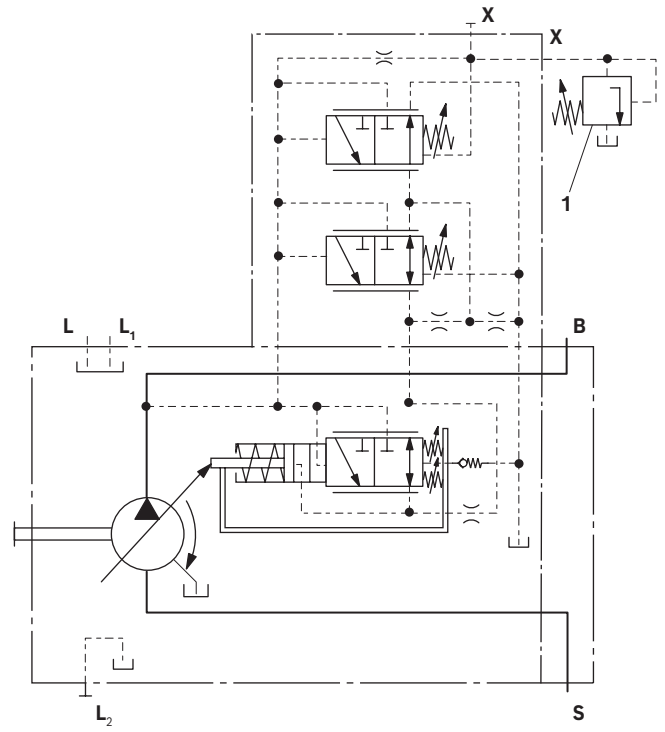

▼ Circuit diagram LA.DS

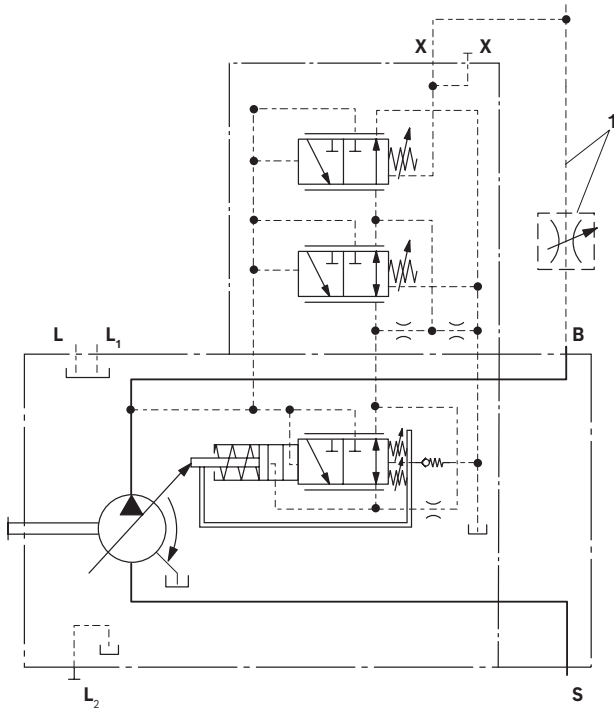

1 The pressure relief valve and the line are not included in the scope of delivery.

1 The metering orifice (control block) and the line is not included in the scope of delivery.

ED – Electrohydraulic pressure control

The ED valve is set to a certain pressure by a specified variable solenoid current.

When changing the consumer (load pressure), this causes an increase or decrease in the pump swivel angle (flow) in order to maintain the electrically set pressure level.

The pump thus only delivers as much hydraulic fluid as the consumers can take. The desired pressure level can be set steplessly by varying the solenoid current.

As the solenoid current signal drops towards zero, the pressure will be limited to p_{max} by an adjustable hydraulic pressure cut-off (secure fail safe function in case of power failure, e.g. for fan speed control). The swivel time characteristic of the ED control was optimized for the use as a fan drive system. When ordering, specify the type of application in plain text.

▼ Current-pressure characteristic curve ED (negative characteristic curve)

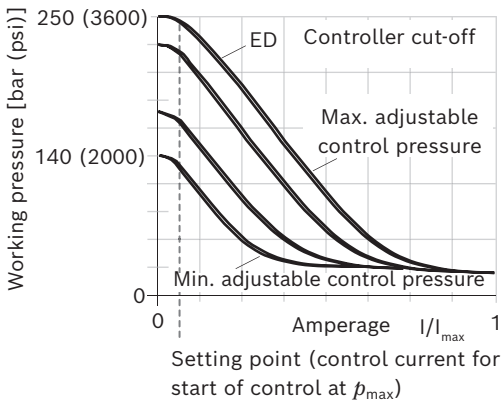

- ▶ Hysteresis static < 25 bar (365 psi).

▼ Flow-pressure characteristic curve

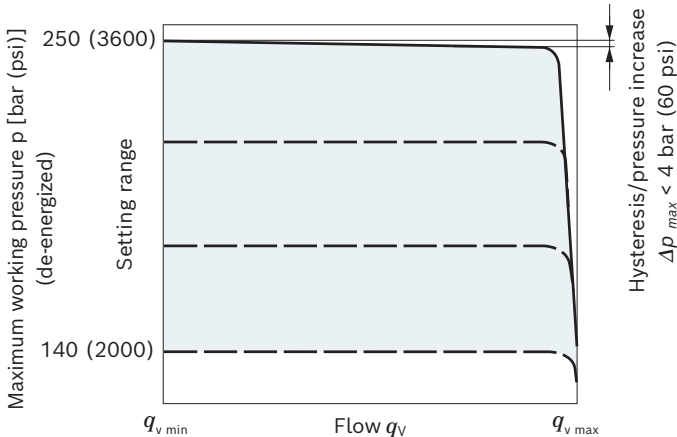

- ▶ Characteristic curves valid at $n_1 = 1500$ rpm and $\vartheta_{fluid} = 50$ °C (120 °F).

- ▶ Pilot fluid consumption: 3 to 4.5 l/min (0.8 to 1.2 gpm).
- ▶ For standby standard setting, see the following diagram, other values on request

▼ Influence of the pressure setting on standby (maximally energized)

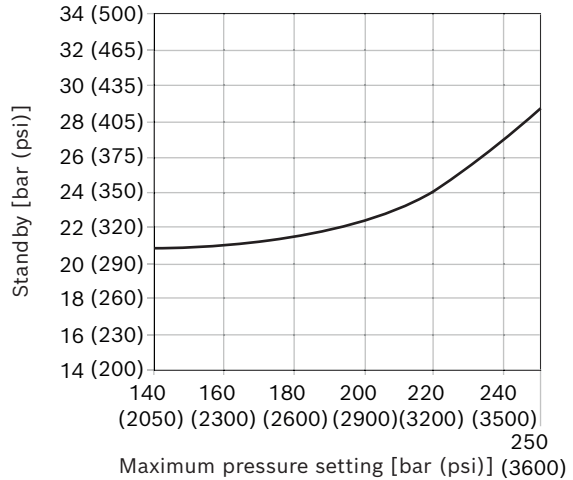

▼ Circuit diagram ED71/ED72

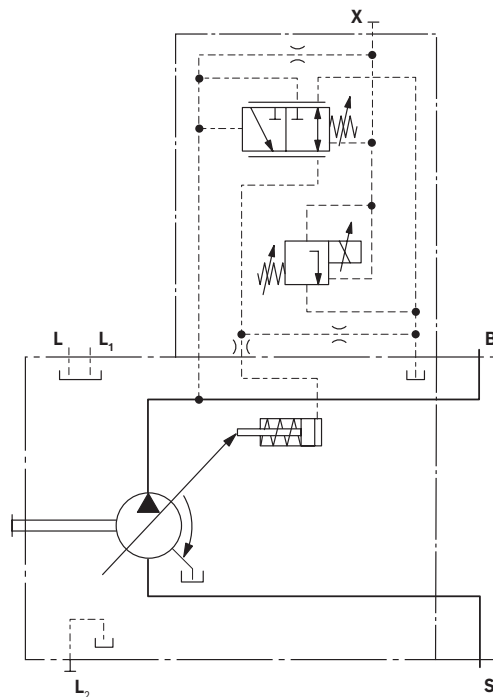

Technical data, solenoids	ED71	ED72
Voltage	12 V (±20%)	24 V (±20%)
Control current		
Start of control at p_{\max}	100 mA	50 mA
End of control at p_{\min}	1200 mA	600 mA
Current limit	1.54 A	0.77 A
Nominal resistance (at 20 °C (68 °F))	5.5 Ω	22.7 Ω
Dither frequency	100 Hz	100 Hz
Recommended amplitude	120 mA	60 mA
Duty cycle	100%	100%
Type of protection: see connector version page 15		
Operating temperature range at valve 20 °C to +115 °C (4 °F to +239 °F)		

The following electronic control units are available for control:

BODAS Controllers	Data sheet
RC5-6, series 40	95207
RC18-12, series 40	95208
RC27-18, series 40	95208

Notice!

With **ED71**, de-energized operating condition (jump from 100 to 0 mA) results in a pressure increase of the maximum pressure of 4 to 5 bar (60 to 75 psi).
 With **ED72**, de-energized operating condition (jump from 50 to 0 mA) results in a pressure increase of the maximum pressure of 4 to 5 bar (60 to 75 psi).

ER – Electrohydraulic pressure control

The ER valve is set to a certain pressure by a specified variable solenoid current. When a change is made at the consumer (load pressure), the position of the control piston will shift.

This causes an increase or decrease in the pump swivel angle (flow) in order to maintain the electrically set pressure level. The pump thus only delivers as much hydraulic fluid as the consumers can take. The desired pressure level can be set steplessly by varying the solenoid current. As the solenoid current signal drops towards zero, the pressure will be limited to p_{min} (stand by).

Observe project planning notes.

▼ Current-pressure characteristic curve ER (positive characteristic curve)

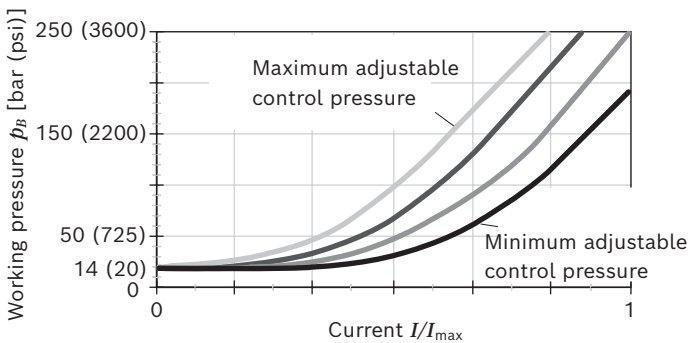

- ▶ Hysteresis static current-pressure characteristic curve < 25 bar (365 psi).

▼ Flow-pressure characteristic curve

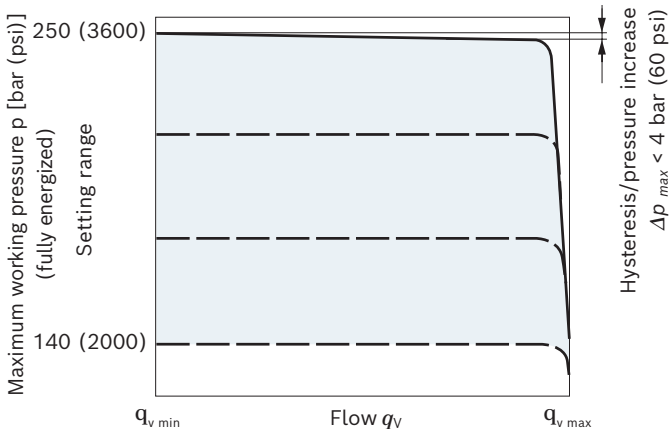

- ▶ Characteristic curves valid at $n_1 = 1500$ rpm and $\vartheta_{fluid} = 50$ °C (120 °F).
- ▶ Pilot fluid consumption: 3 to 4.5 l/min (0.8 to 1.2 gpm).
- ▶ Standby standard 14 bar (200 psi). Other values on request.
- ▶ Influence of pressure setting on standby ± 2 bar (± 30 psi).

▼ Circuit diagram ER71/ER72

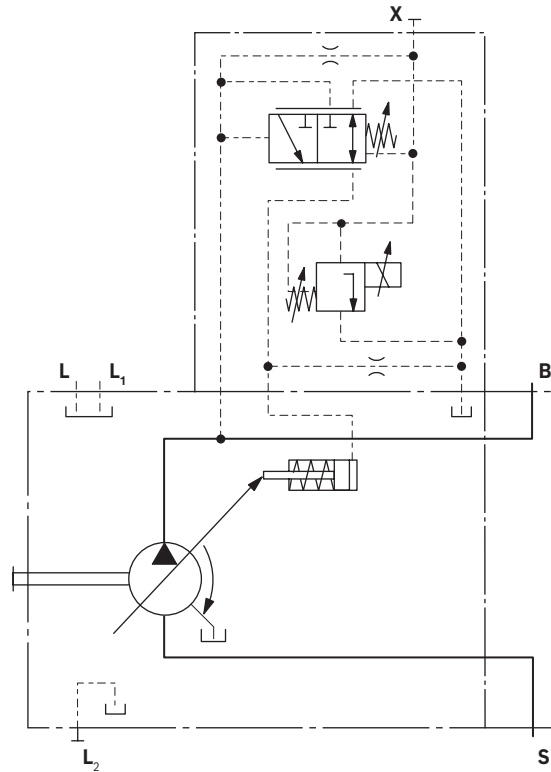

Technical data, solenoids	ER71	ER72
Voltage	12 V ($\pm 20\%$)	24 V ($\pm 20\%$)
Control current		
Start of control at p_{min}	100 mA	50 mA
End of control at p_{max}	1200 mA	600 mA
Current limit	1.54 A	0.77 A
Nominal resistance (at 20 °C (68 °F))	5.5 Ω	22.7 Ω
Dither frequency	100 Hz	100 Hz
Recommended amplitude	120 mA	60 mA
Duty cycle	100%	100%
Type of protection: see connector version page 78		
Operating temperature range at valve 20 °C to +115 °C (4 °F to +239 °F)		

Project planning note!

Excessive current levels ($I > 1200$ mA at 12 V or $I > 600$ mA at 24 V) to the ER solenoid can result in undesired pressure increases which can lead to pump or system damage. Therefore:

- ▶ Use I_{max} current limiter solenoids.

EP – Electro proportional control

Electro proportional control makes a continuous and reproducible setting of the pump displacement possible directly via the cradle. The control force of the control piston is applied by a proportional solenoid. The control is proportional to the current (for start of control, see table right).

In a depressurized state, the pump is swiveled to its initial position ($V_{g \max}$) by an adjusting spring. If the working pressure exceeds a limit value of approx. 4 bar (60 psi), the pump starts to swivel from $V_{g \max}$ to $V_{g \min}$ without control by the solenoid (control current < start of control). With a minimum swivel angle $V_{g \min}$ and de-energized EP solenoids, a minimum pressure of 10 bar (145 psi) must be maintained.

A PWM signal is used to control the solenoid.

EP.D: The pressure control regulates the pump displacement back to $V_{g \min}$ after the pressure command value has been reached.

A minimum working pressure of 14 bar (200 psi) is needed for safe and reproducible control. The required control fluid is taken from the high pressure.

▼ Characteristic curve EP1/2

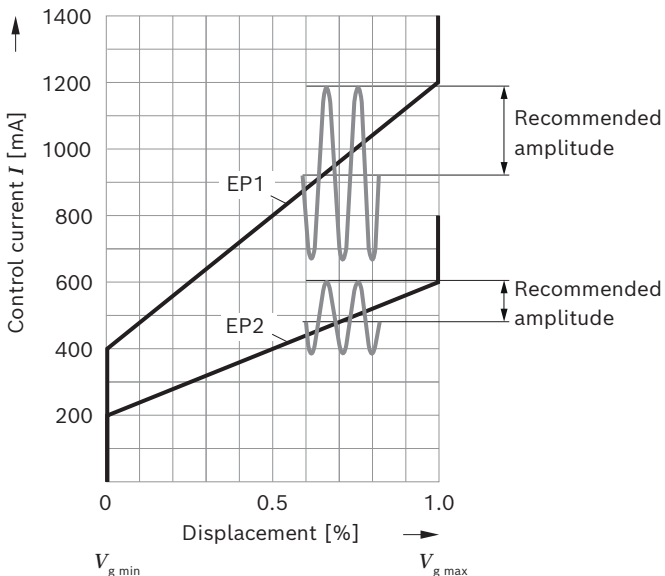

- Hysteresis static current-displacement characteristic curve < 5 %.

▼ Circuit diagram EP.D

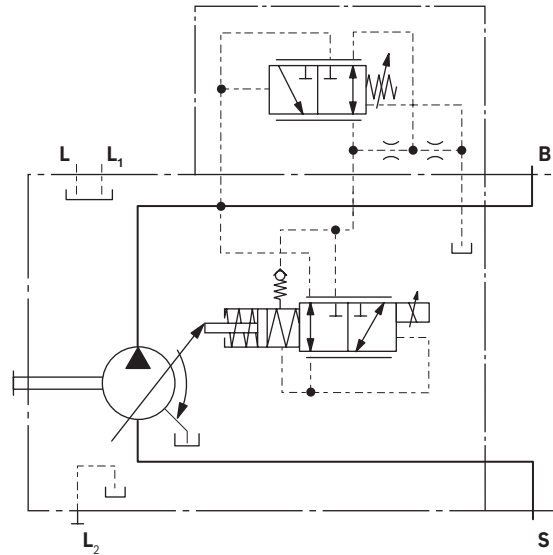

Technical data, solenoids	EP1	EP2
Voltage	12 V (±20%)	24 V (±20%)
Control current		
Start of control at $V_{g \min}$	400 mA	200 mA
End of control at $V_{g \max}$	1200 mA	600 mA
Dither frequency	100 Hz	100 Hz
Recommended amplitude	120 mA	60 mA
Current limit	1.54 A	0.77 A
Nominal resistance (at 20 °C (68 °F))	5.5 Ω	22.7 Ω
Duty cycle	100%	100%
Type of protection: see connector version page 78		
Operating temperature range at valve -20 °C to +115 °C (4 °F to +239 °F)		

Notice!

We recommend the valve with flushing function for the EP.D control variant. Please contact us.

The following electronic control units are available for control:

BODAS Controllers	Data sheet
RC5-6, series 40	95207
RC18-12, series 40	95208
RC27-18, series 40	95208

EK – Electro proportional control with controller cut-off

Variant EK... is based completely on the variant EP... (see page 23).

In addition to the electro proportional control function, a controller cut-off is integrated in the electric characteristic curve. The pump then swivels to $V_{g \max}$ if the pilot signal is lost (e.g. cable break) and then works with the DRF settings if necessary (see page 16).

The controller cut-off is only intended for short-term use and not for continuous operation if the pilot signal is lost. If the pilot signal is lost, the pump swivel times will be increased by the EK valve.

A PWM signal is used to control the solenoid.

Notice!

A minimum working pressure of 50 bar (725 psi) is needed for safe and reproducible electro proportional control with controller cut-off. For lower pressures, a pilot signal of > 500 mA (EK2) or > 1000 mA (EK1) is required in order to avoid undesired controller cut-off. The required control fluid is taken from the high pressure.

In $V_{g \max}$ position, the spring force of the return spring is maximum. To overcome this spring force, the solenoid must be subjected to excessive current (I_{res}).

▼ Characteristic curve EK1/2

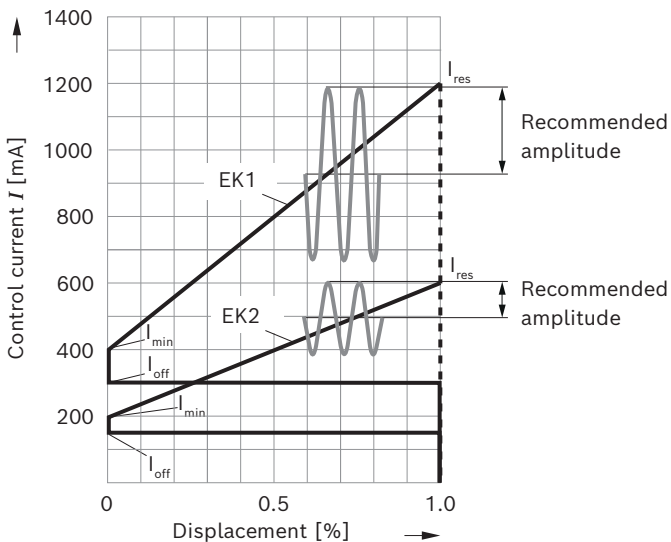

- Hysteresis static current-displacement characteristic curve < 5 %
- For changes in EK1, ramp times of > 200 ms must be observed.

▼ Circuit diagram EK.D

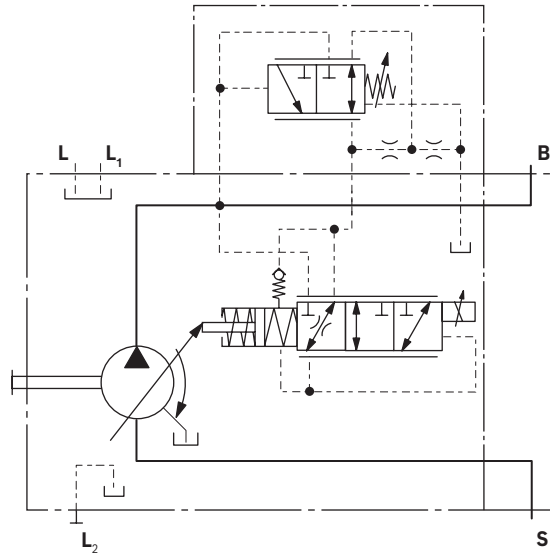

Technical data, solenoids	EK1	EK2
Voltage	12 V (±20%)	24 V (±20%)
Control current		
Start of control at $V_{g \min}$	400 mA	200 mA
End of control at $V_{g \max}$	1200 mA	600 mA
Dither frequency	100 Hz	100 Hz
Recommended amplitude	120 mA	60 mA
Current limit	1.54 A	0.77 A
Nominal resistance (at 20 °C (68 °F))	5.5 Ω	22.7 Ω
Duty cycle	100%	100%
Type of protection: see connector version page 78		
Operating temperature range at valve -20 °C to +115 °C (4 °F to +239 °F)		

	EK1	EK2
I_{\min} [mA]	400	200
I_{\max} [mA]	1200	600
I_{off} [mA]	< 300	< 150
I_{res} [mA]	> 1200	> 600

Notice!

We recommend the valve with flushing function for the EK.D control variant. Please contact us.

The following electronic control units are available for control:

BODAS Controllers	Data sheet
RC5-6, series 40	95207
RC18-12, series 40	95208
RC27-18, series 40	95208

EP(K).DF / EP(K).DS / EP(K) – with pressure flow controller

A hydraulic pressure flow control is superimposed on the electro proportional control.

The pressure control regulates the pump displacement infinitely varied back to $V_{g\ min}$ after the set pressure command value has been reached.

This function is super-imposed on the EP or EK control, i.e. the control-current dependent EP or EK function is executed below the pressure command value.

For the setting range of the pressure flow controller, see page 14 to 16.

With all controller combinations, the V_g reduction has priority.

With flow control, the pump flow can be influenced in addition to pressure control. The pump flow is thus equal to the actual amount of hydraulic fluid required by the consumer. This is achieved using the differential pressure at the consumer (e.g. orifice).

The EP.DS or EK.DS version has no connection between X and the reservoir (load-sensing). Please refer to the notes on page 16.

▼ Circuit diagram EP.DF

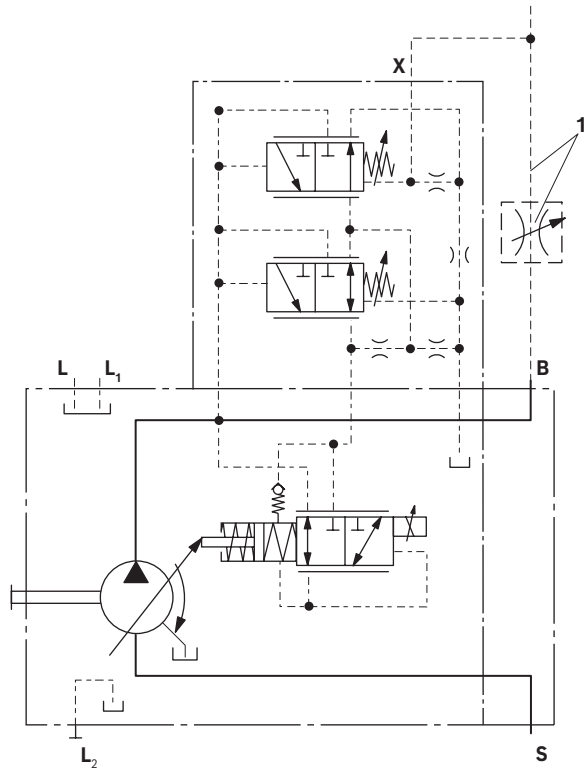

▼ Circuit diagram EP.D

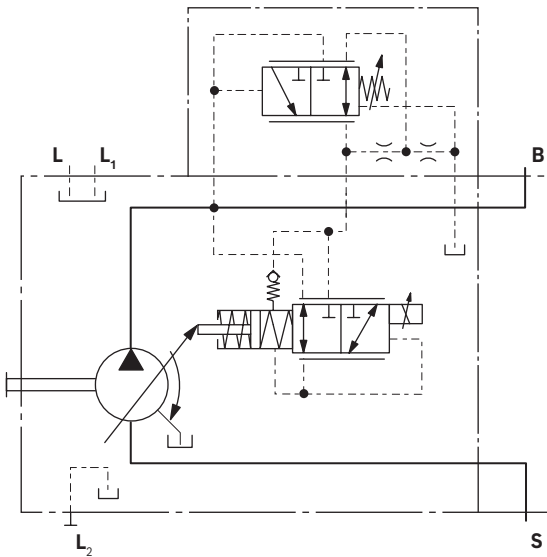

▼ Circuit diagram EP.DS

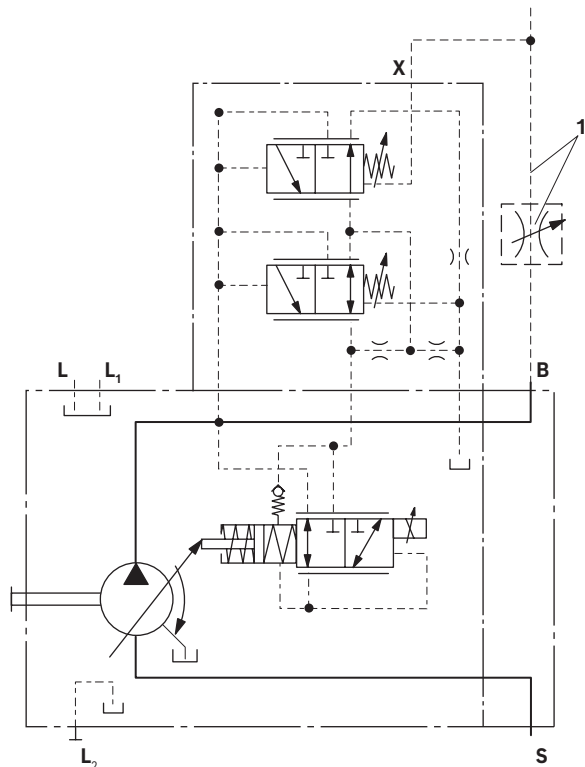

1 The metering orifice (control block) and the line is not included in the scope of delivery.

EP.ED / EK.ED – with electrohydraulic pressure control

The ED valve is set to a certain pressure by a specified variable solenoid current. When changing the consumer (load pressure), this causes an increase or decrease in the pump swivel angle (flow) in order to maintain the electrically set pressure level.

The pump thus only delivers as much hydraulic fluid as the consumers can take. The pressure can be set steplessly by the solenoid current.

As the solenoid current signal drops towards zero, the pressure will be limited to p_{max} by an adjustable hydraulic pressure cut-off (negative characteristic curve, e.g. for fan speed control). A PWM signal is used to control the solenoid.

For further information and technical data of the solenoids for ED(ER) control please refer to pages 20 to 24.

▼ Circuit diagram EP.ED

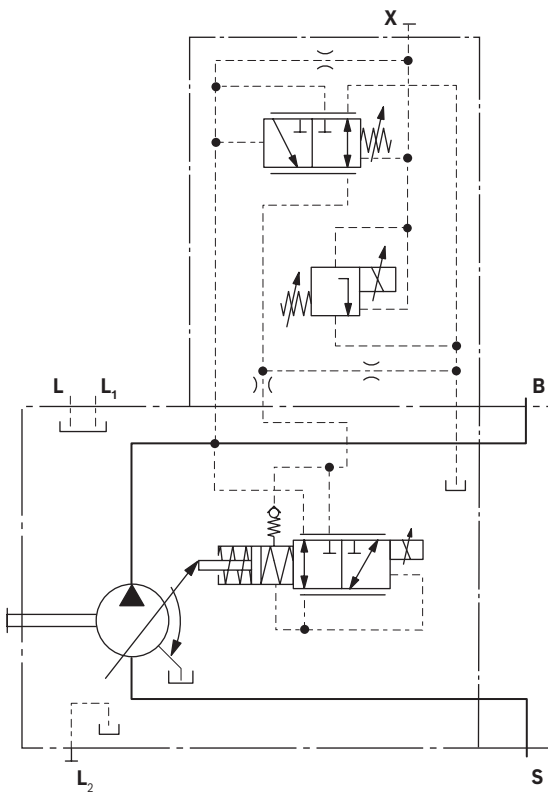

▼ Circuit diagram EK.ED

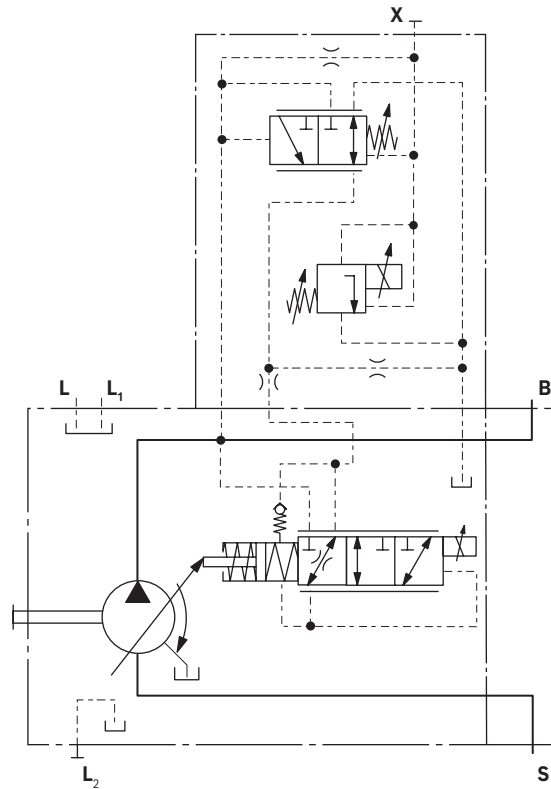

EC4 – Electro-hydraulic control valve (positive control)

The proportional directional valve EC4 serves to control an axial piston variable pump with eOC control functions in an electronically connected control circuit.

The valve spool is clamped between a proportional solenoid and a spring and releases a opening cross-section depending on the stroke.

This results in a proportionality of the solenoid current with respect to the opening cross-section and thus the swiveling speed of the pump.

The neutral position, which does not lead to a swivel motion, is assigned to a respective neutral current.

If the solenoid current is above the neutral current ($I_{neutral}$), the pump swivels in the direction of $V_{g\ max}/100\%$; if it is below, the pump swivels in the direction of $V_{g\ min}/0\%$.

A swivel angle sensor is required for control of the pump with BODAS eOC. It must be specified in type code position 13.

Further information about the swivel angle sensor PAL2/20 is provided on page 79 and in data sheet 95161.

Further information on project planning of the BODAS eOC control system including other required system components can be found in data sheet 95345.

The BODAS eOC control software supports all four basic control types of axial piston variable pumps in electrically connected control circuits:

- ▶ Pressure and differential pressure regulation (p)
- ▶ Swivel angle and flow control (α)
- ▶ Torque control (M)
- ▶ Power control

▼ Control variants with EC4

Representation for positive quadrants 0% to +100%

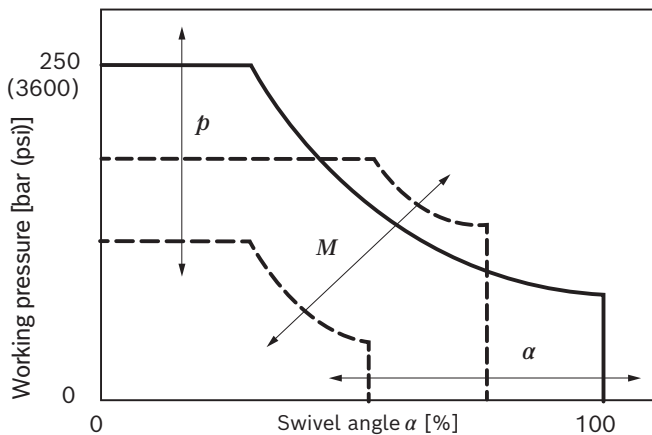

▼ Circuit diagram EC4

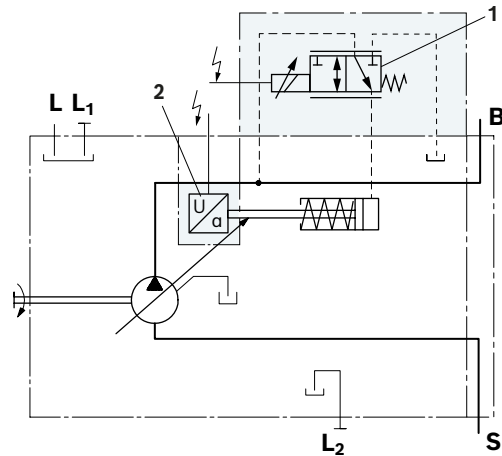

- 1 Proportional directional valve EC4
- 2 Swivel angle sensor (see data sheet 95161)

The following electronic control units are available for control:

BODAS Controllers	Data sheet
RC5-6, series 40	95207
RC18-12, series 40	95208
RC27-18, series 40	95208

For further technical data on the solenoid with respective information, see pages 28 and 78

▼ Operating principle EC4

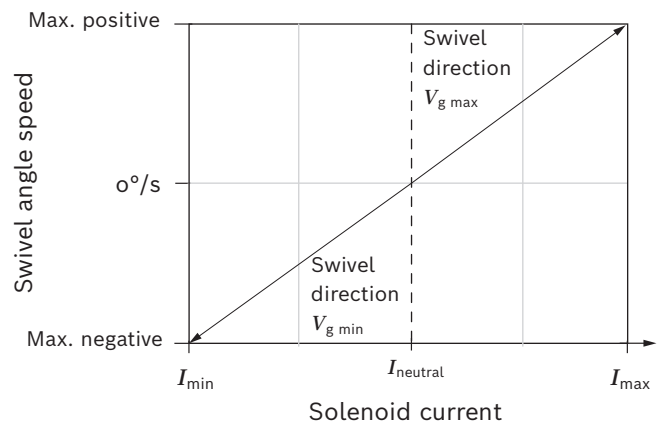

Solenoid technical data

EC4	
Maximum solenoid current	1900 mA
Nominal resistance at 20 °C (68 °F) winding temperature	4.26 ±0.26 Ω
Hot resistance 180 °C (356 °F) winding temperature	6.92 ±0.42 Ω
Limit temperature for winding	Insulating material class H (180 °C (356 °F))
Hydraulic fluid or operating temperature	from -40 °C to 110 °C (-40 °F to 230 °F)
Type of protection: see connector version page 78	

Notice

- ▶ The limit voltage of the coil is 36 VDC. In general, the maximum current must not be exceeded by the actual current.
- ▶ For calculation of the hot resistance, a temperature coefficient of 0.0039k^{-1} is to be applied.

▼ **Characteristic curve of permitted operating range**

Example: At a hydraulic fluid temperature of 88 °C (190 °F), an ambient temperature of 110 °C (230 °F) is permitted.

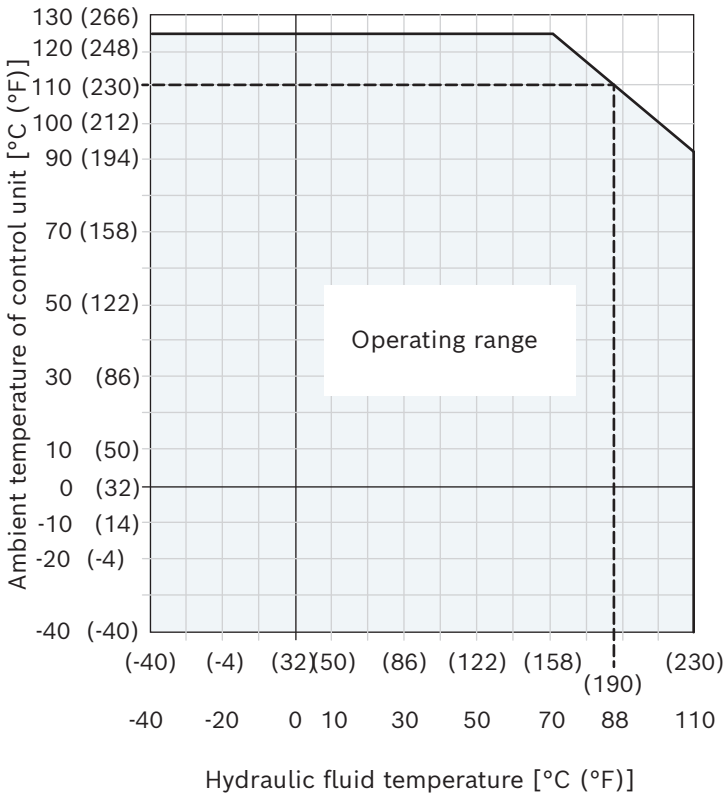

Dimensions, size 10

DR - Pressure controller; mounting flange C SAE version; port plate 14 (64); series 52

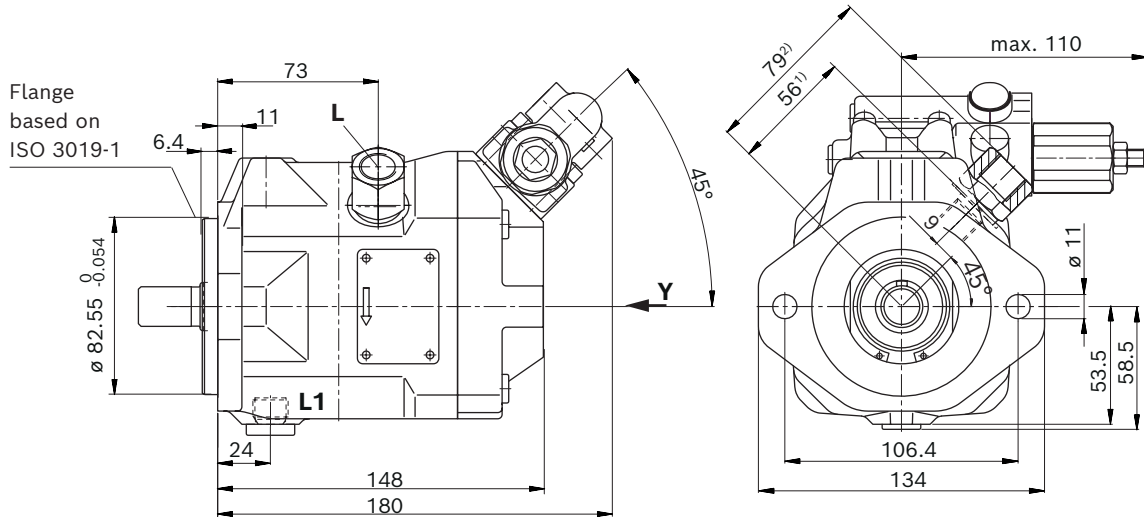

▼ **View Y**
 Valve mounting for clockwise rotation

▼ **View Y**
 Valve mounting for counter-clockwise rotation

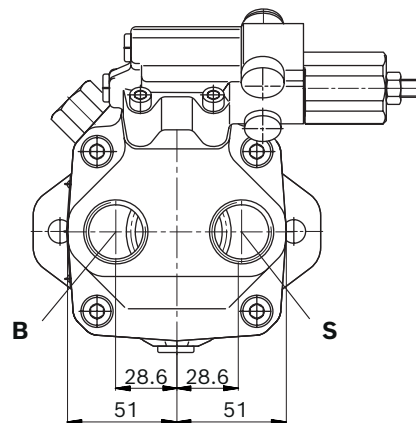
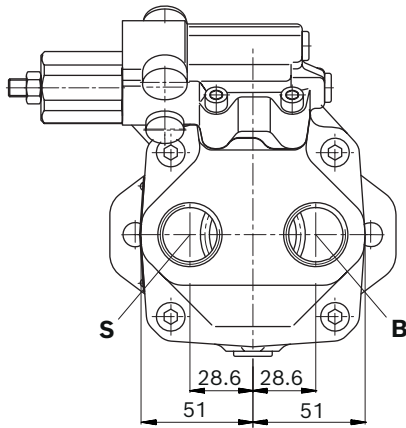

1) With port plate 64
 2) With port plate 14

Dimensions, size 10

DR – Pressure controller; mounting flange A metric version; port plate 14; series 52

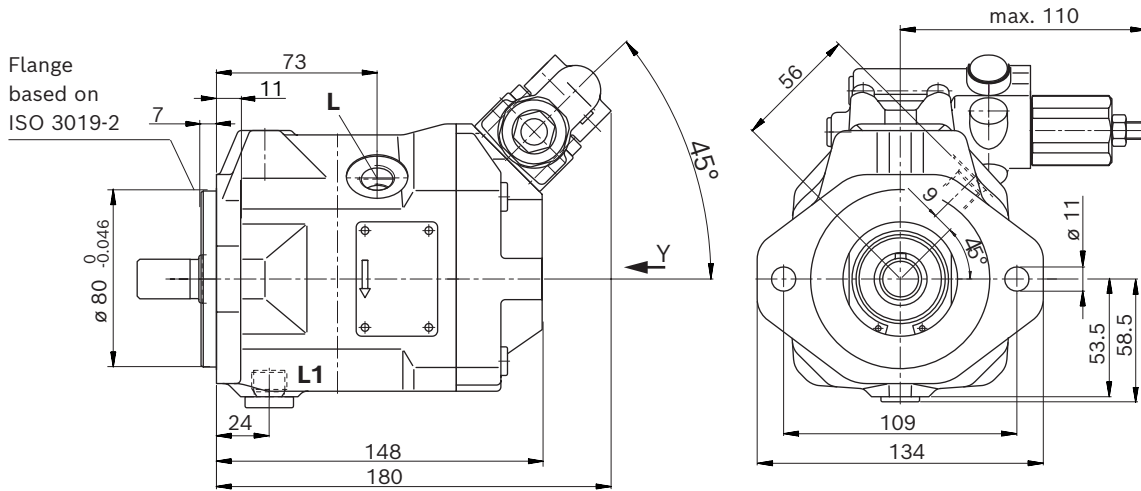

▼ **View Y**
 Valve mounting
 for clockwise
 rotation

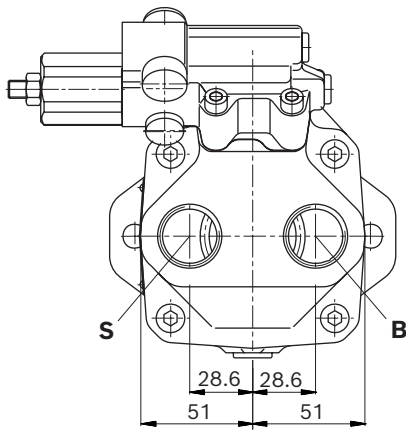

▼ **View Y**
 Valve mounting
 for counter-clockwise
 rotation

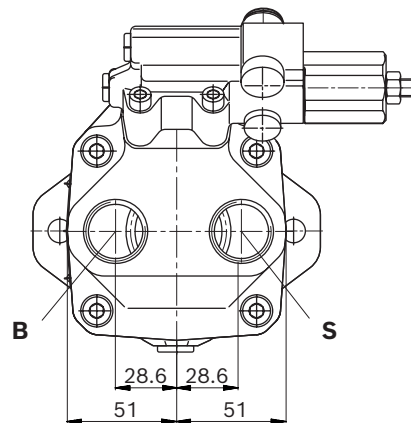

▼ Splined shaft 3/4 in (19-4, ISO 3019-1)

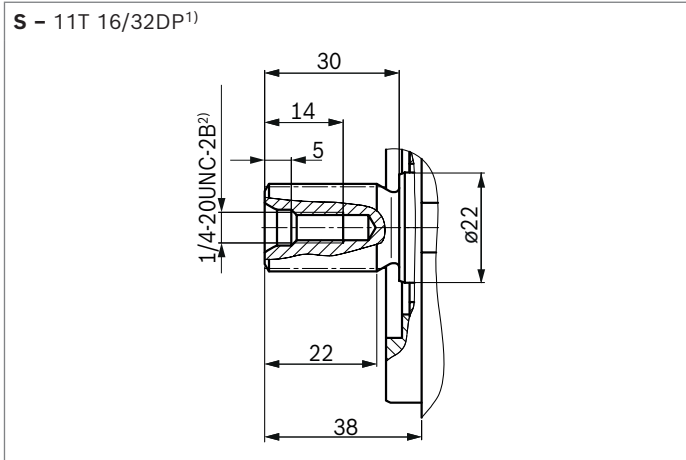

▼ Splined shaft 5/8 in (16-4, ISO 3019-1)

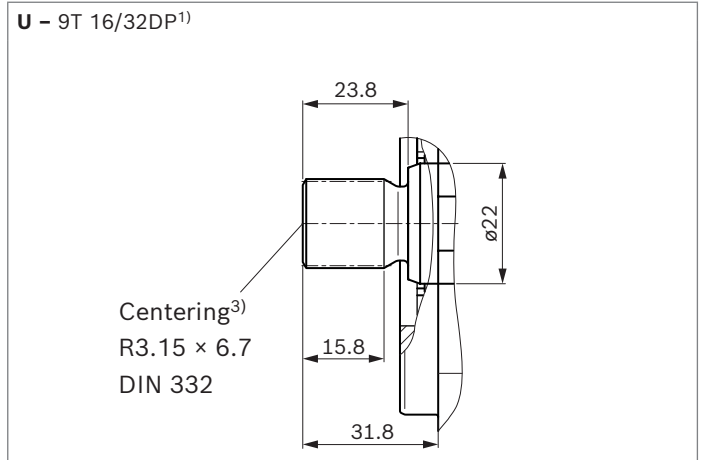

▼ Parallel keyed shaft DIN 6885

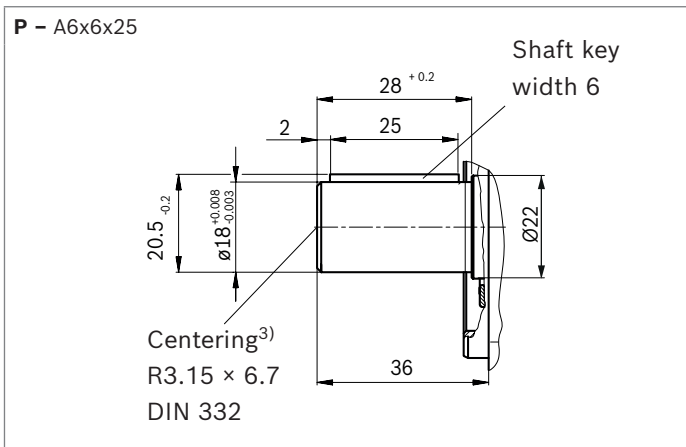

▼ Parallel keyed shaft ISO 3019-1

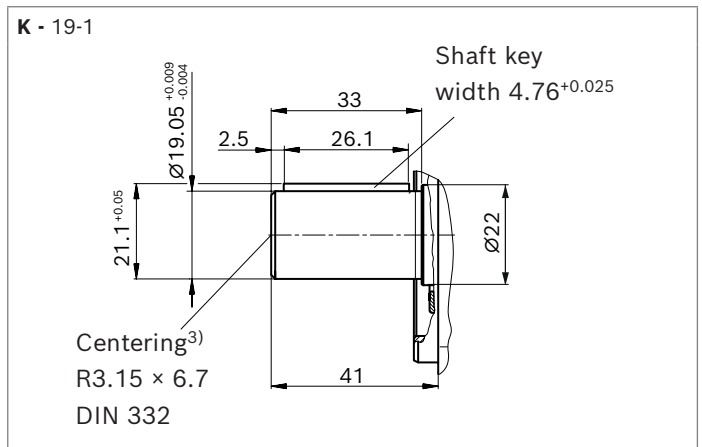

Mounting flange A ports (metric); port plate 14		Standard	Size	p_{\max} [bar (psi)] ⁴⁾	State ⁷⁾
B	Working port	DIN 3852	M27 × 2; 16 (0.63) deep	315 (4550)	O
S	Suction port	DIN 3852	M27 × 2; 16 (0.63) deep	5 (75)	O
L	Drain port	DIN 3852 ⁵⁾	M16 × 1.5; 12 (0.47) deep	2 (30)	O ⁶⁾
L₁	Drain port	DIN 3852 ⁵⁾	M16 × 1.5; 12 (0.47) deep	2 (30)	X ⁶⁾
X with adapter	Pilot pressure	DIN 3852	M14 × 1.5; 12 (0.47) deep	315 (4550)	O
Mounting flange C ports (SAE); port plate 64		Standard	Size	p_{\max} [bar (psi)] ⁴⁾	State ⁷⁾
B	Working port	ISO 11926	1 1/16-12UNF-2B; 20 (0.79) low	315 (4550)	O
S	Suction port	ISO 11926	1 1/16-12UNF-2B; 20 (0.79) low	5 (75)	O
L without adapter (standard)	Drain port	ISO 11926 ⁵⁾	9/16-18UNF-2B; 12 (0.47) deep	2 (30)	O ⁶⁾
L with adapter	Drain port	ISO 3852 ⁵⁾	M16 × 1.5; 12 (0.47) deep	2 (30)	O ⁶⁾
L₁ without adapter	Drain port	ISO 11926 ⁵⁾	9/16-18UNF-2B; 12 (0.47) deep	2 (30)	X ⁶⁾
X without adapter (standard)	Pilot pressure	ISO 11926	7/16-20UNF-2B; 11.5 (0.45) deep	315 (4550)	O
X with adapter	Pilot pressure	ISO 3852	M14 × 1.5; 12 (0.47) deep	315 (4550)	O

- 1) Involute spline according to ANSI B92.1a, 30° pressure angle, flat root, side fit, tolerance class 5
- 2) Thread according to ASME B1.1
- 3) Coupling axially secured, e.g. with a clamp coupling or radially mounted clamping screw

- 4) Depending on the application, momentary pressure peaks can occur. Keep this in mind when selecting measuring devices and fittings.
- 5) The countersink may be deeper than specified in the standard.
- 6) Depending on the installation position, **L** or **L₁** must be connected (also see installation instructions starting on page 80).
- 7) O = Must be connected (plugged on delivery)
X = Plugged (in normal operation)

▼ **DRG - Pressure controller, remote controlled**
(mounting flange A)¹⁾

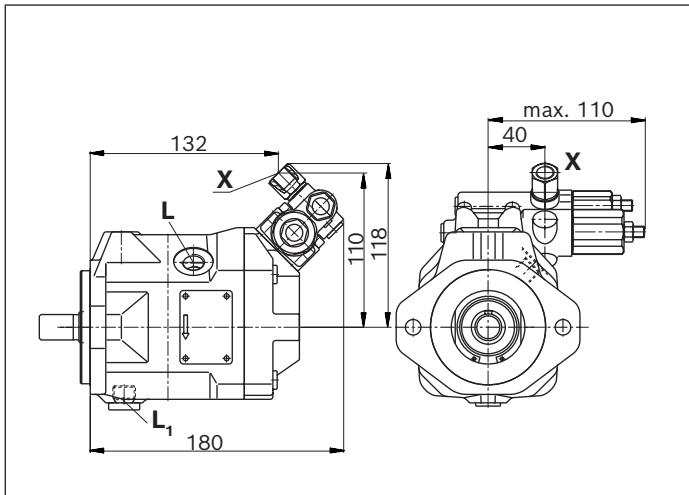

▼ **DFR/DFR1 - Pressure, flow controller**
(mounting flange A)¹⁾

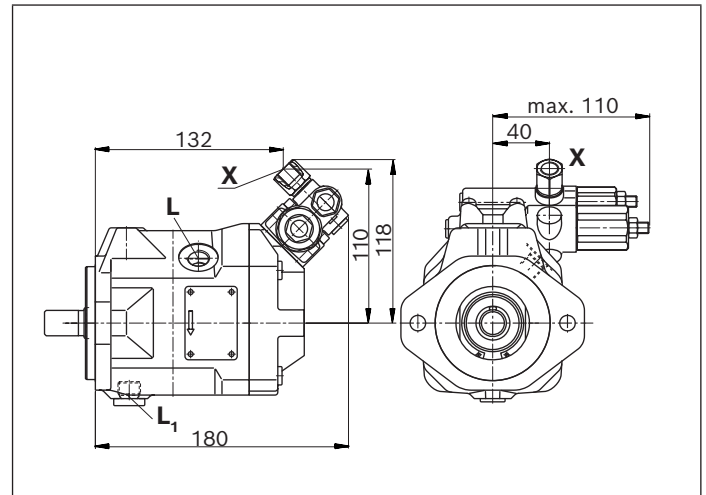

▼ **DRG - Pressure controller, remote controlled**
(mounting flange C)¹⁾²⁾

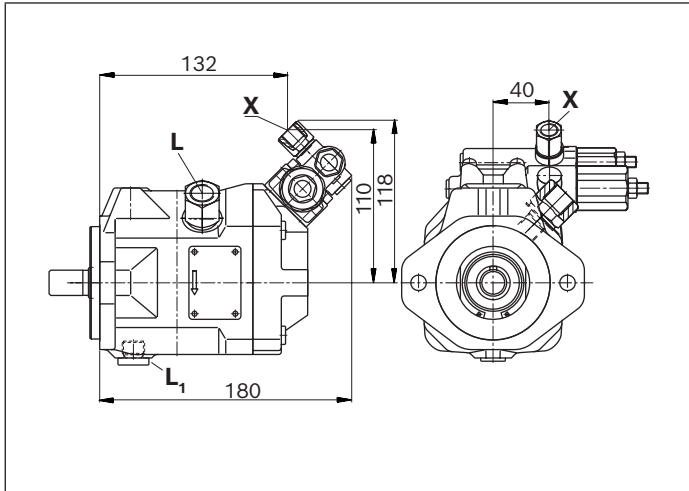

▼ **DFR/DFR1 - Pressure, flow controller**
(mounting flange C)¹⁾²⁾

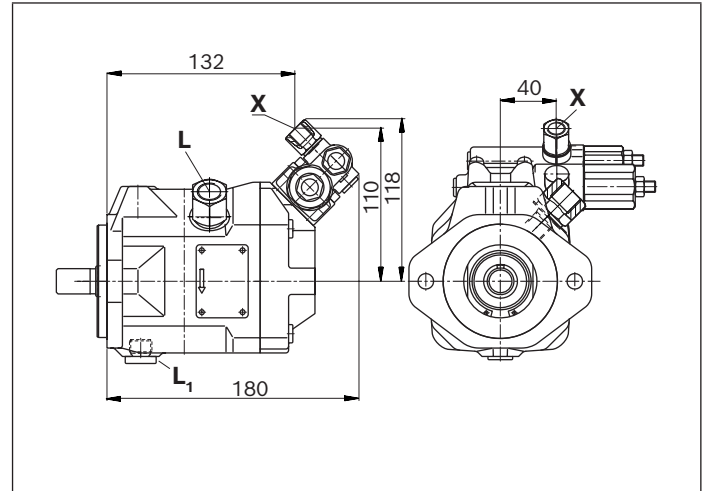

▼ **DRG - Pressure controller, remote controlled**
(mounting flange C)¹⁾³⁾

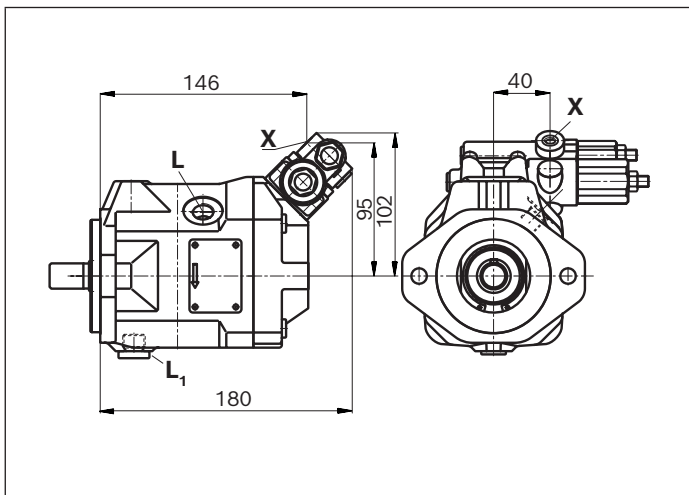

▼ **DFR/DFR1 - Pressure, flow controller**
(mounting flange C)¹⁾³⁾

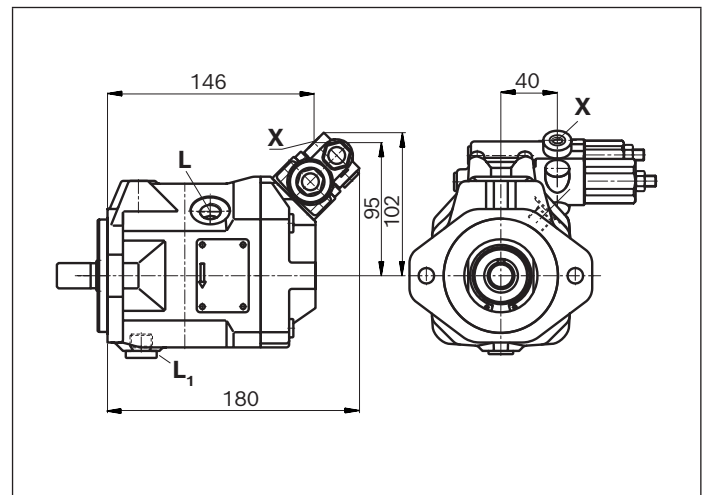

- 1) Valve mounting for clockwise or counter-clockwise rotation see page 29 and 30
- 2) With metric adapter
- 3) Version complete SAE without adapter

Dimensions, size 18

DR – Hydraulic pressure controller; clockwise rotation, series 53

▼ Port plate 11 (61)

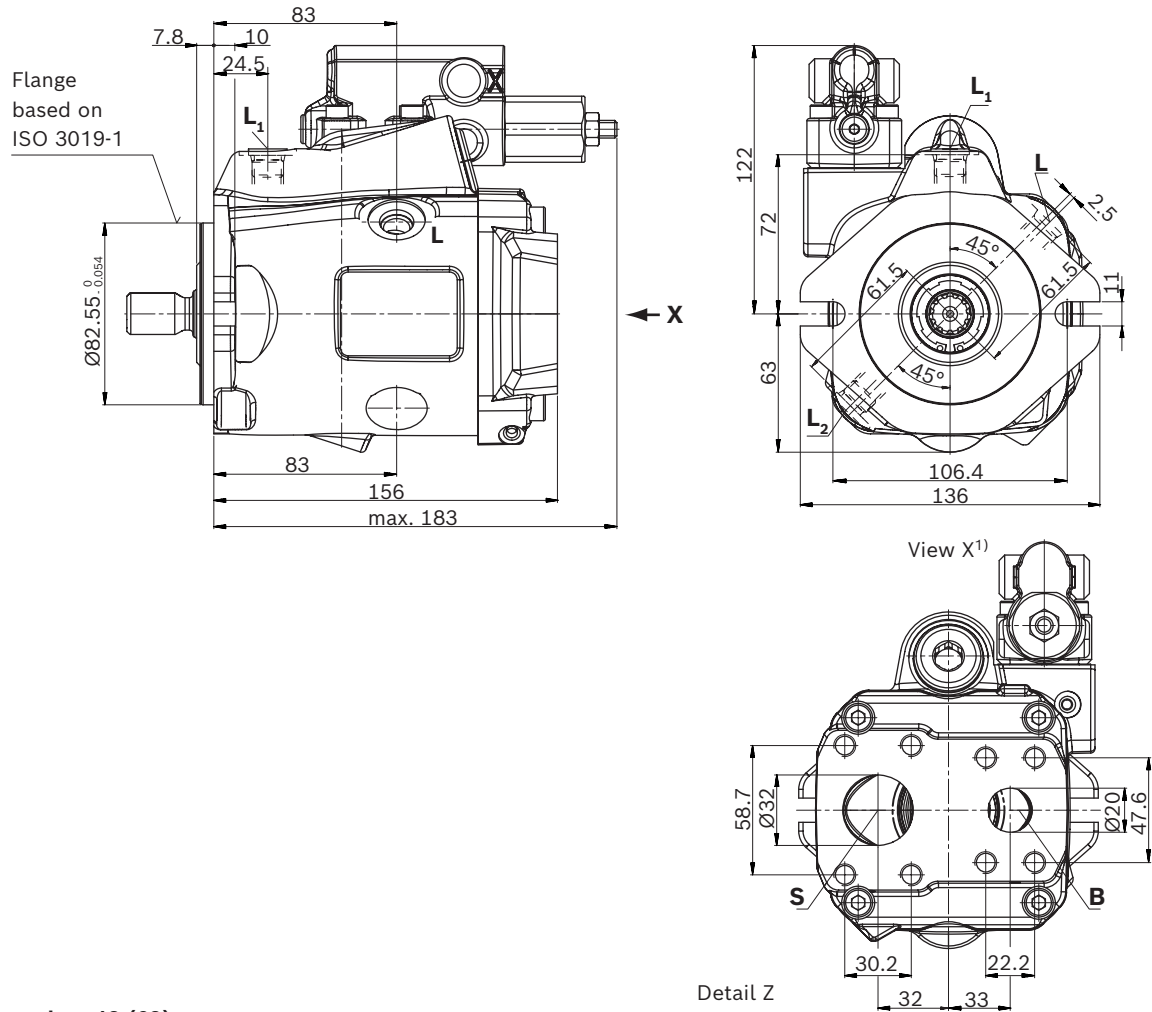

▼ Port plate 12 (62)

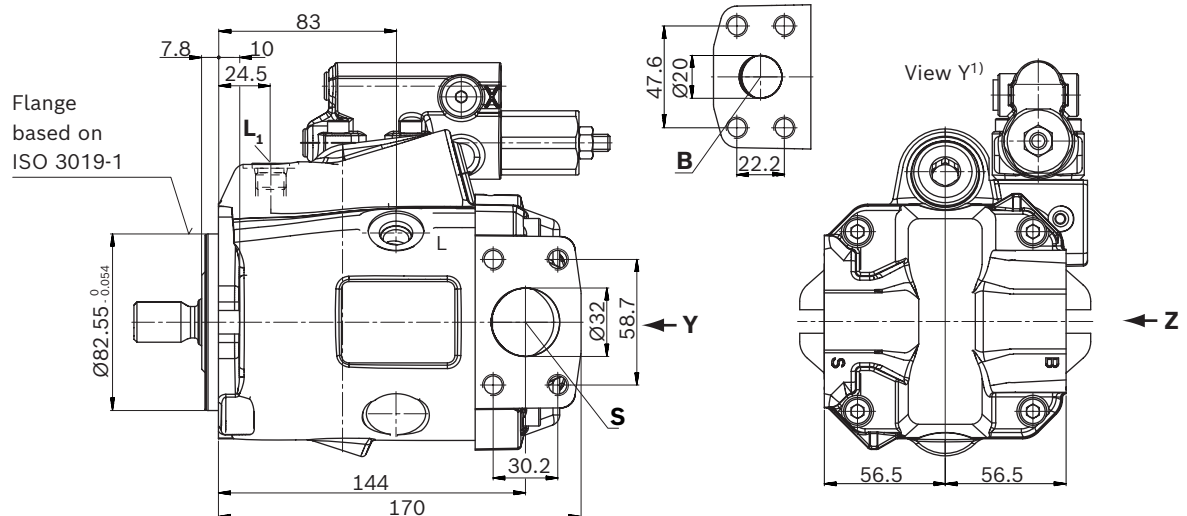

1) Dimensions of working ports turned through 180° for counter-clockwise rotation

▼ **Splined shaft 3/4 in (19-4, ISO 3019-1)**

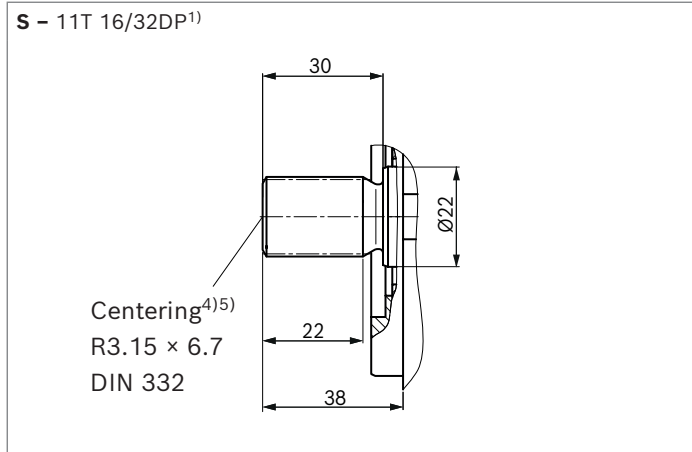

▼ **Splined shaft 3/4 in (similar to ISO 3019-1)**

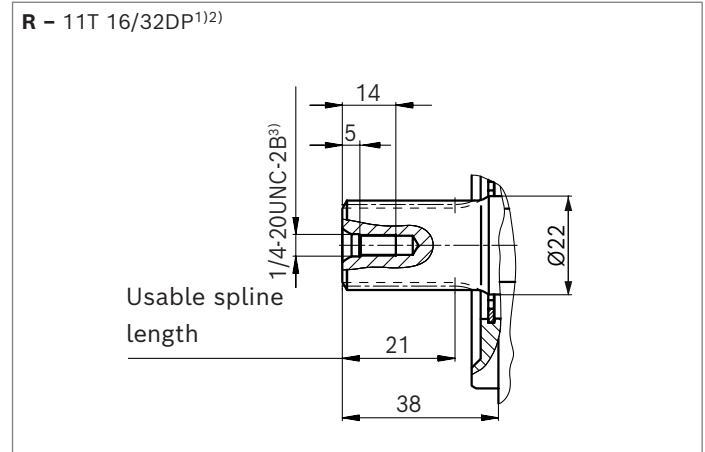

▼ **Splined shaft 5/8 in (16-4, ISO 3019-1)**

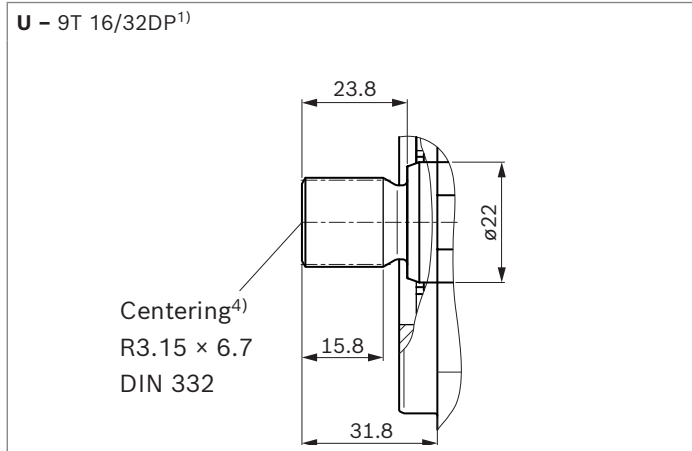

▼ **Parallel keyed shaft ISO 3019-1**

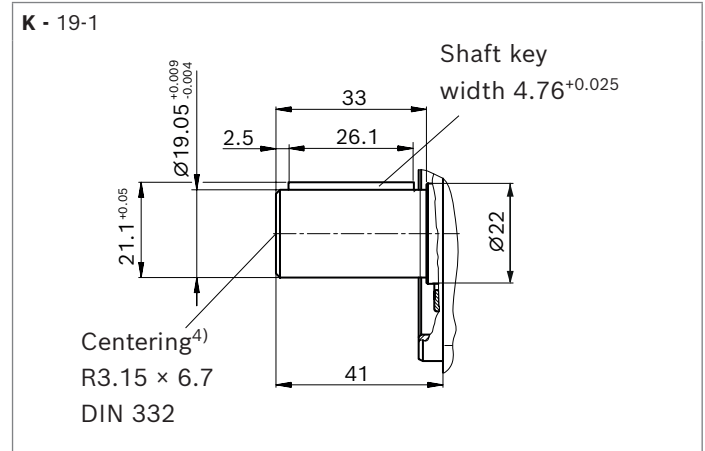

Port plate 11, 12		Standard	Size	p_{max} [bar (psi)] ⁶⁾	State ⁹⁾
B	Working port (standard pressure series)	ISO 6162-1	3/4 in	315 (4550)	O
	Fastening thread	DIN 13	M10 × 1.5; 17 (0.67) deep		
S	Suction port (standard pressure series)	ISO 6162-1	1 1/4 in	5 (75)	O
	Fastening thread	DIN 13	M10 × 1.5; 17 (0.67) deep		
Port plate 61, 62		Standard	Size	p_{max} [bar (psi)] ⁶⁾	State ⁹⁾
B	Working port (standard pressure series)	ISO 6162-1	3/4 in	315 (4550)	O
	Fastening thread	ASME B1.1	3/8-16UNC-2B; 19 (0.75) deep		
S	Suction port (standard pressure series)	ISO 6162-1	1 1/4 in	5 (75)	O
	Fastening thread	ASME B1.1	7/16-14UNC-2B; 24 (0.94) deep		
Other ports		Standard	Size	p_{max} [bar (psi)] ⁶⁾	State ⁹⁾
L	Drain port	ISO 11926 ⁷⁾	3/4-16UNF-2B; 12 (0.47) deep	2 (30)	O ⁸⁾
L₁, L₂	Drain port	ISO 11926 ⁷⁾	3/4-16UNF-2B; 12 (0.47) deep	2 (30)	X ⁸⁾
X	Pilot pressure	ISO 11926	7/16-20UNF-2B; 11.5 (0.45) deep	315 (4550)	O

1) Involute spline according to ANSI B92.1a, 30° pressure angle, flat root, side fit, tolerance class 5
 2) Splines according to ANSI B92.1a, spline runout is a deviation from standard ISO 3019-1.
 3) Thread according to ASME B1.1
 4) Coupling axially secured, e.g. with a clamp coupling or radially mounted clamping screw
 5) Thread 1/4-20UNC-2B for units with through drive exists see valid EBZ

6) Depending on the application, momentary pressure peaks can occur. Keep this in mind when selecting measuring devices and fittings.
 7) The countersink may be deeper than specified in the standard.
 8) Depending on the installation position, **L**, **L₁** or **L₂** must be connected (also see installation instructions starting on page 80).
 9) O = Must be connected (plugged on delivery)
 X = Plugged (in normal operation)

▼ **DRG – Pressure controller, remote controlled, series 53**

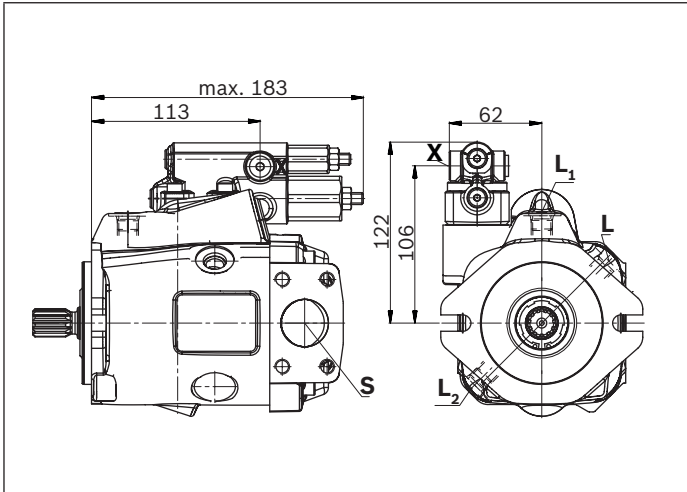

▼ **EP.D. / EK.D. – Electro proportional control, series 53**

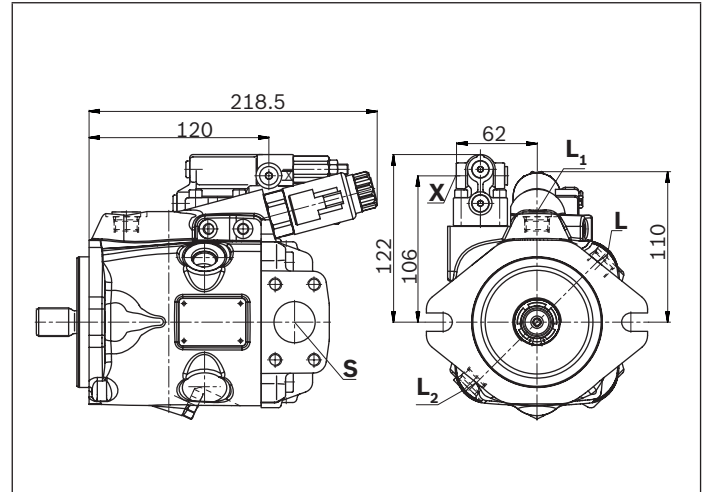

▼ **DRF/DRS/DRSC – Pressure flow controller, series 53**

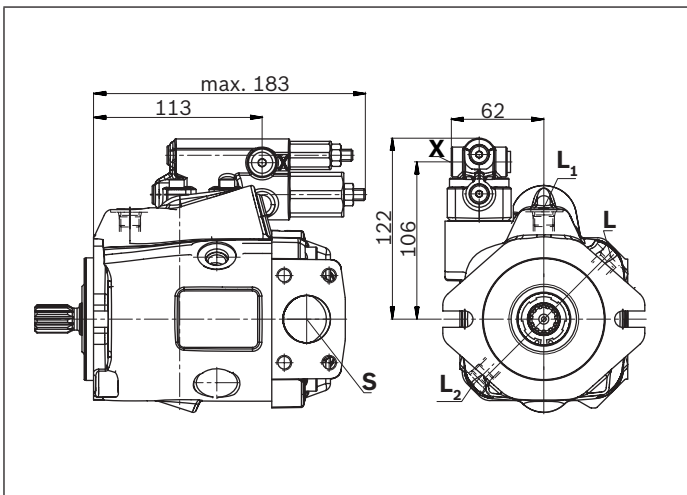

▼ **EP.ED. / EK.ED. – Electro-prop. control, series 53**

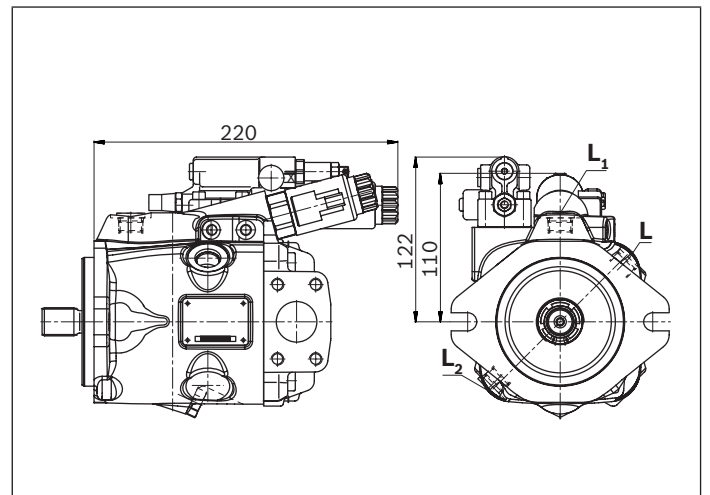

▼ **LA.D. – Pressure, flow and power controller, series 53**

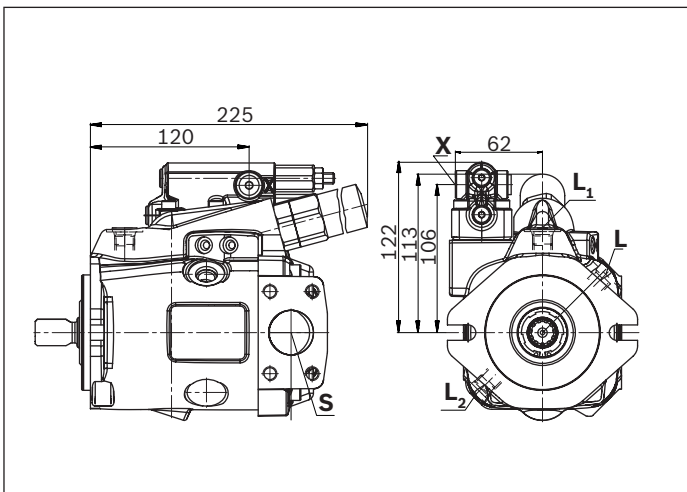

▼ **ED7. / ER7. – Electro-prop. pressure control, series 53**

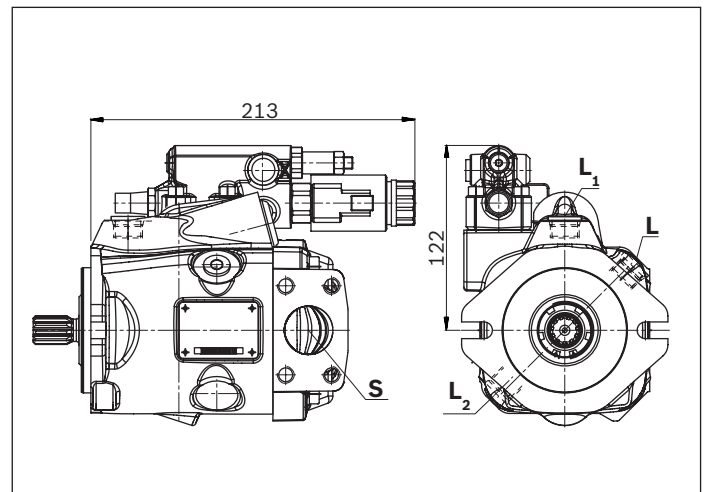

Dimensions, size 28

DR – Hydraulic pressure controller; clockwise rotation, series 52

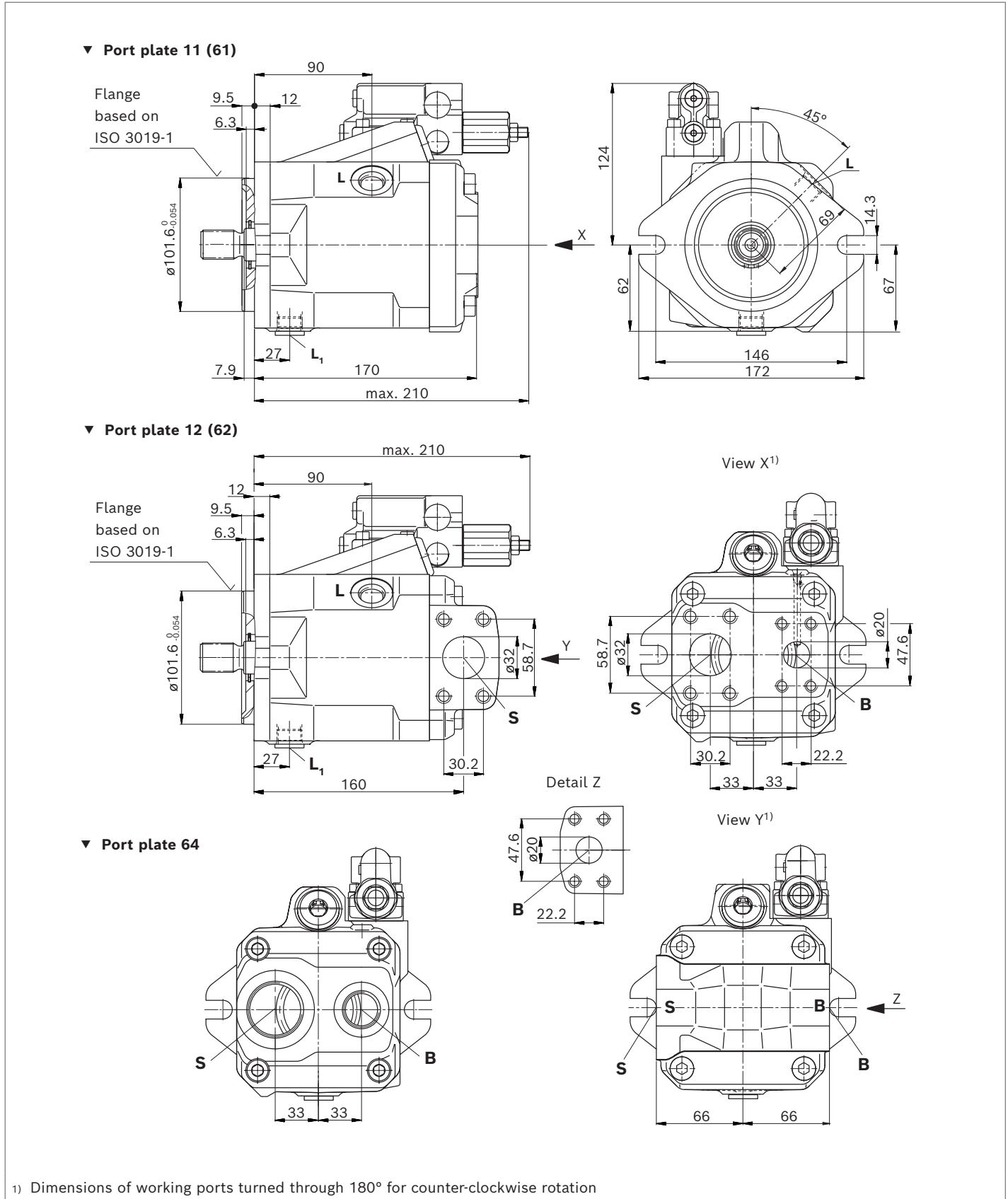

Dimensions, size 28

DR – Hydraulic pressure controller; clockwise rotation, series 53

▼ **Port plate 11 (61)**

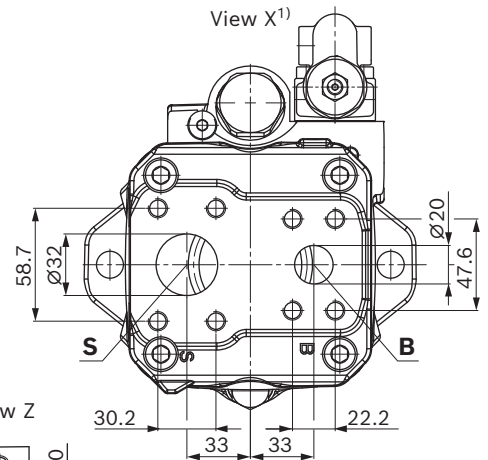
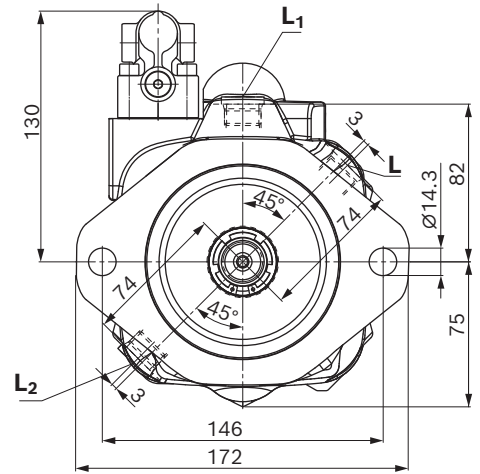
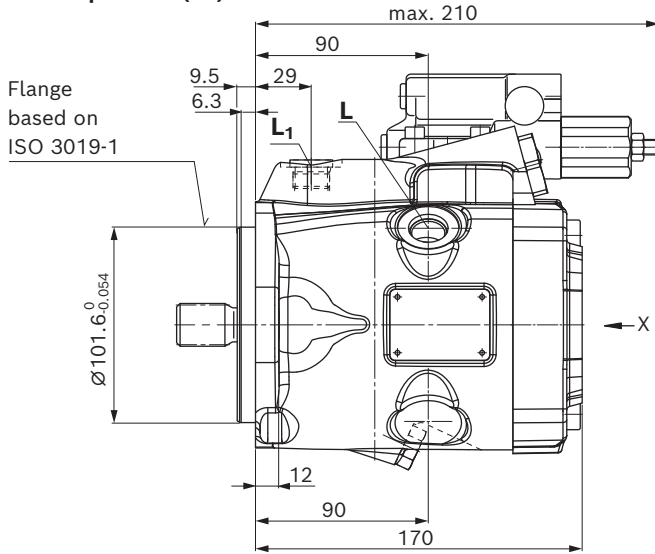

▼ **Port plate 12 (62)**

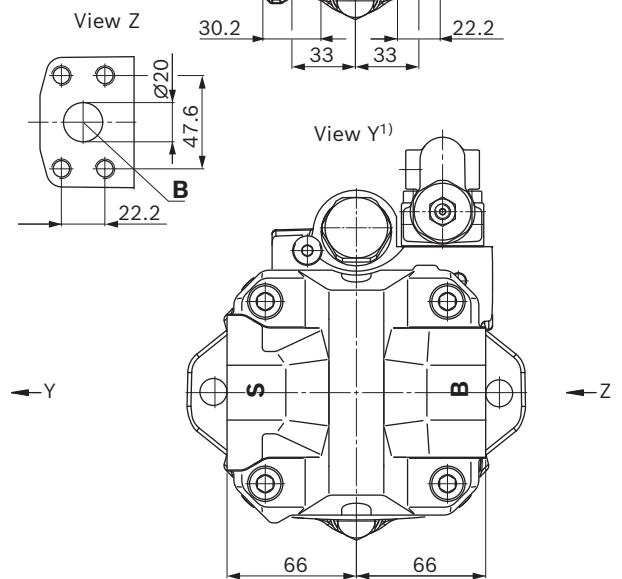
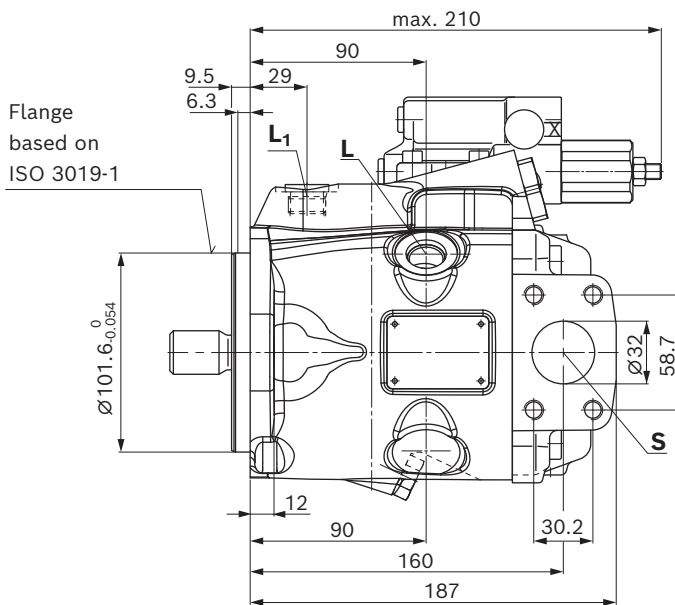

1) Dimensions of working ports turned through 180° for counter-clockwise rotation

▼ **Splined shaft 7/8 in (22-4, ISO 3019-1)**

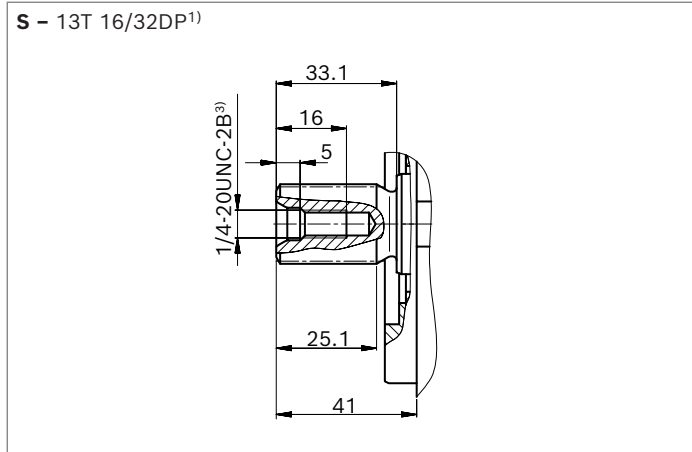

▼ **Splined shaft 7/8 in (similar to ISO 3019-1)**

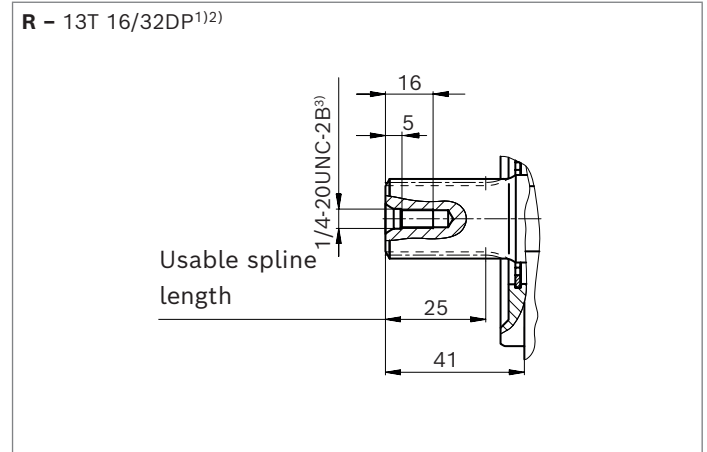

▼ **Splined shaft 3/4 in (19-4, ISO 3019-1)**

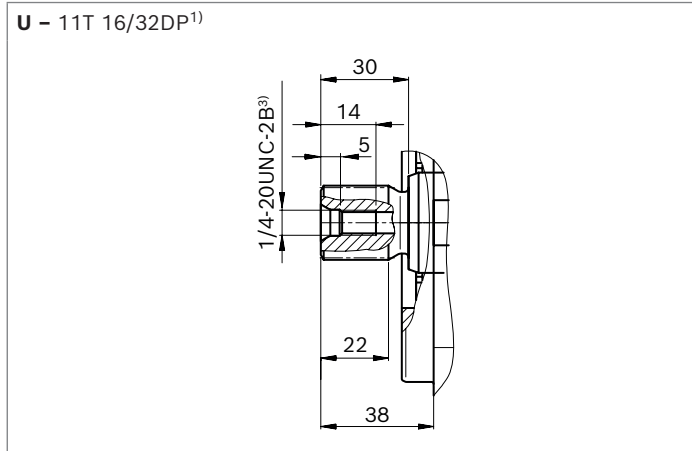

▼ **Splined shaft 3/4 in (similar to ISO 3019-1)**

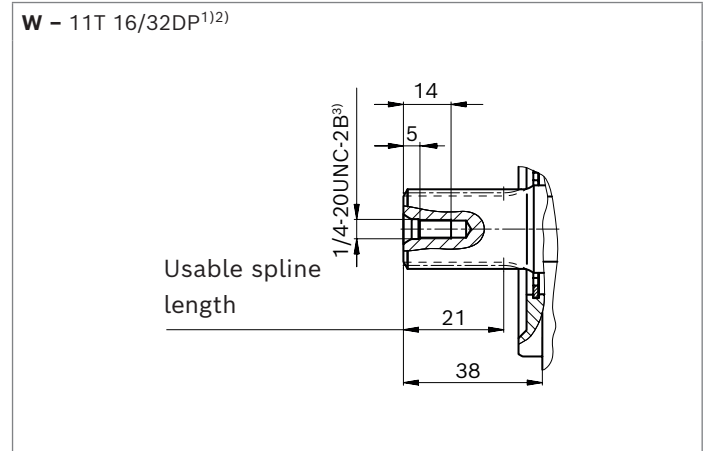

▼ **Parallel keyed shaft ISO 3019-1**

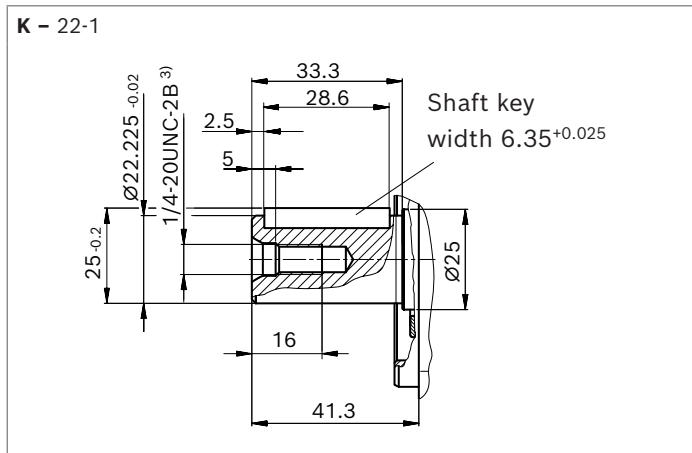

▼ **Tapered keyed shaft (ISO 3019-1)**

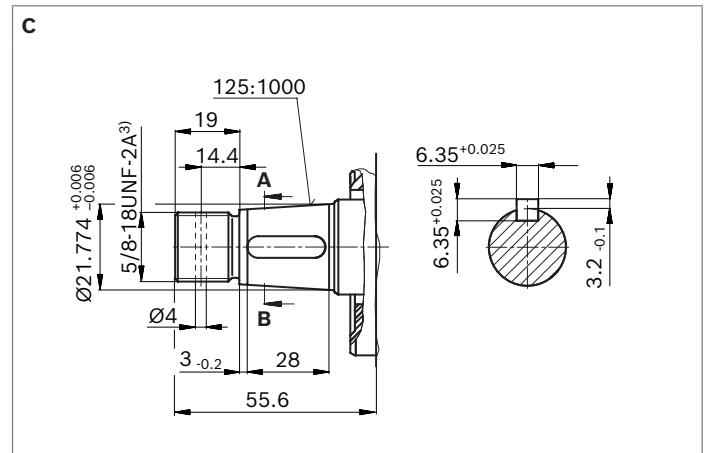

- 1) Involute spline according to ANSI B92.1a, 30° pressure angle, flat root, side fit, tolerance class 5
- 2) Splines according to ANSI B92.1a, spline runout is a deviation from standard ISO 3019-1.
- 3) Thread according to ASME B1.1

Port plate 11, 12		Standard	Size	p_{\max} [bar (psi)] ¹⁾	State ⁵⁾
B	Working port (standard pressure series)	ISO 6162-1	3/4 in	315 (4550)	O
	Fastening thread	DIN 13	M10 × 1.5; 17 (0.67) deep		
S	Suction port (standard pressure series)	ISO 6162-1	1 1/4 in	5 (75)	O
	Fastening thread	DIN 13	M10 × 1.5; 17 (0.67) deep		
Port plate 61, 62		Standard	Size	p_{\max} [bar (psi)] ¹⁾	State ⁵⁾
B	Working port (standard pressure series)	ISO 6162-1	3/4 in	315 (4550)	O
	Fastening thread	ASME B1.1	3/8-16UNC-2B 19 (0.75) deep		
S	Suction port (standard pressure series)	ISO 6162-1	1 1/4 in	5 (75)	O
	Fastening thread	ASME B1.1	7/16-14UNC-2B; 24 (0.94) deep		
Port plate 64		Standard	Size	p_{\max} [bar (psi)] ¹⁾	State ⁵⁾
B	Working port	ISO 11926	1 1/16 12 UN-2B; 20 (0.79) deep	315 (4550)	O
S	Suction port	ISO 11926	1 5/8 12UN-2B; 17 (0.67) deep	5 (75)	O
Other ports		Standard	Size	p_{\max} [bar (psi)] ¹⁾	State ⁵⁾
L	Drain port	ISO 11926 ²⁾	3/4-16UNF-2B; 12 (0.47) deep	2 (30)	O ³⁾
L₁, L₂⁴⁾	Drain port	ISO 11926 ²⁾	3/4-16UNF-2B; 12 (0.47) deep	2 (30)	X ³⁾
X	Pilot pressure	ISO 11926	7/16-20UNF-2B; 11.5 (0.45) deep	315 (4550)	O

1) Depending on the application, momentary pressure peaks can occur.
Keep this in mind when selecting measuring devices and fittings.

2) The countersink may be deeper than specified in the standard.

3) Depending on the installation position, **L**, **L₁** or **L₂** must be connected (also see installation instructions starting on page 80).

4) Only for series 53

5) O = Must be connected (plugged on delivery)
X = Plugged (in normal operation)

▼ **DRG – Pressure controller, remote controlled, series 52**

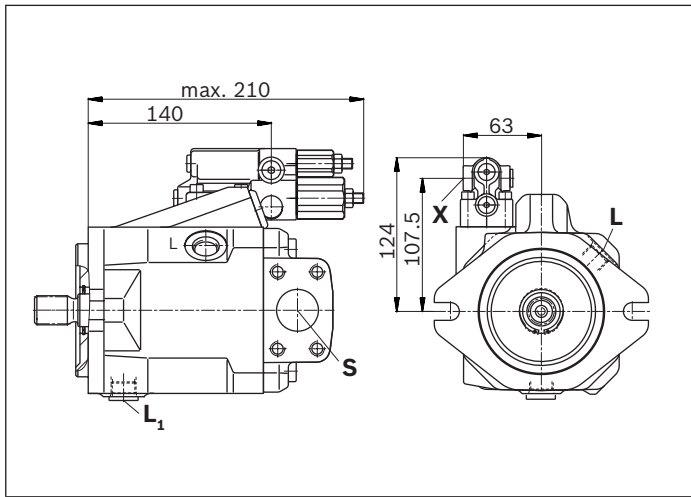

▼ **DFR/DFR1 – Pressure flow controller, series 52**

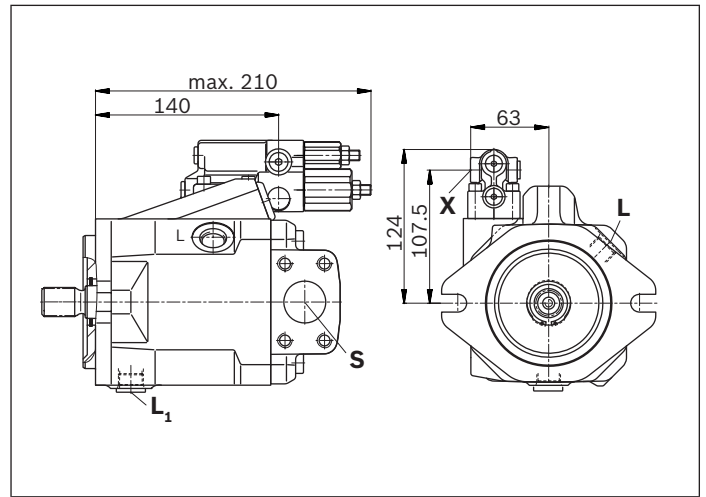

▼ **EC4 – Electro-hydraulic control valve, series 52**

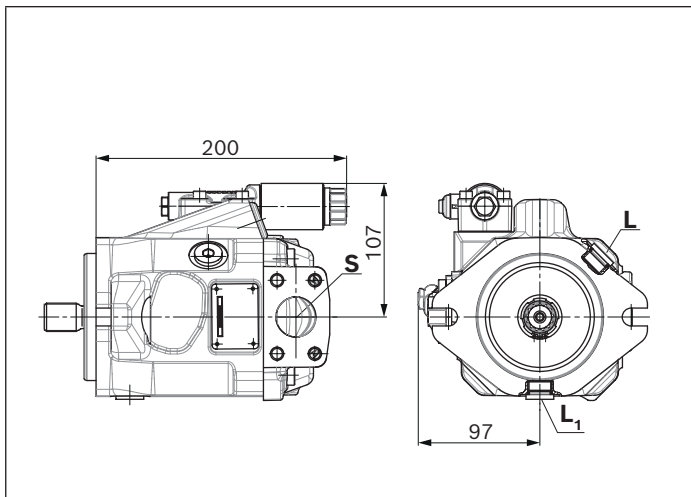

▼ **ED7. / ER7. – Electro-prop. pressure control, series 52**

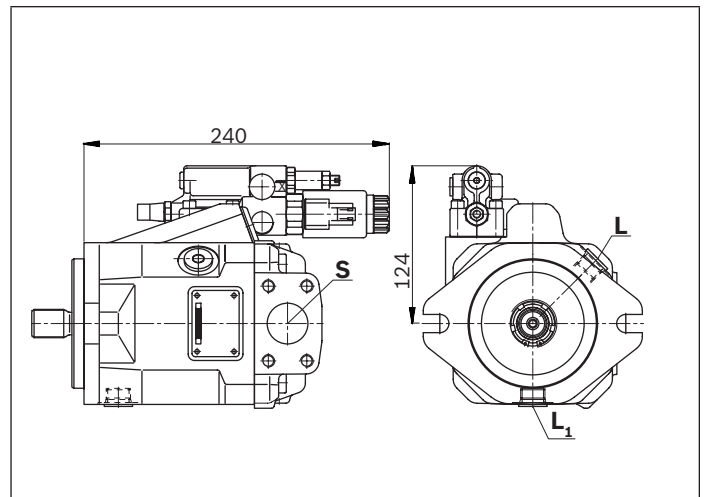

▼ **DRG – Pressure controller, remote controlled, series 53**

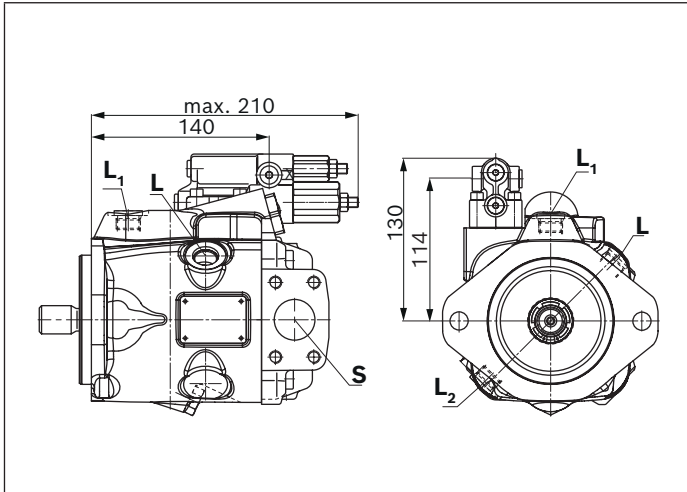

▼ **EP.D. / EK.D. – Electro proportional control, series 53**

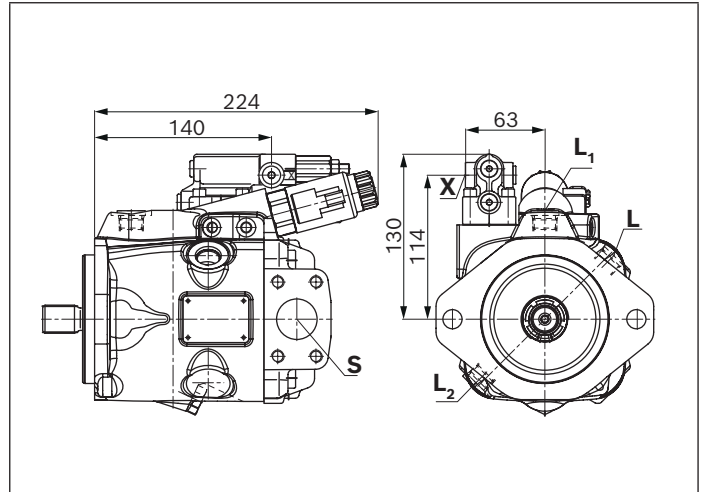

▼ **DRF/DRS/DRSC – Pressure flow controller, series 53**

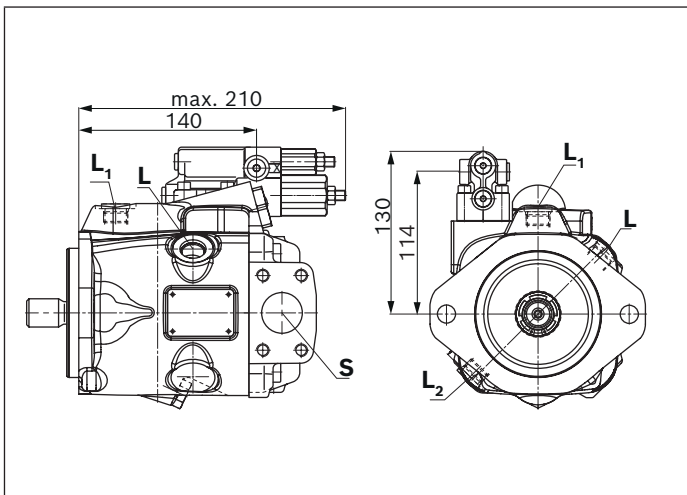

▼ **EP.ED. / EK.ED. – Electro proportional control, series 53**

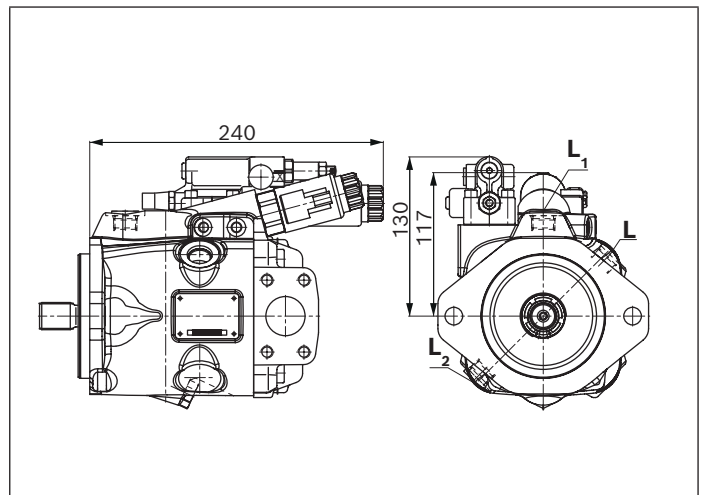

▼ **LA.D. – Pressure, flow and power controller, series 53**

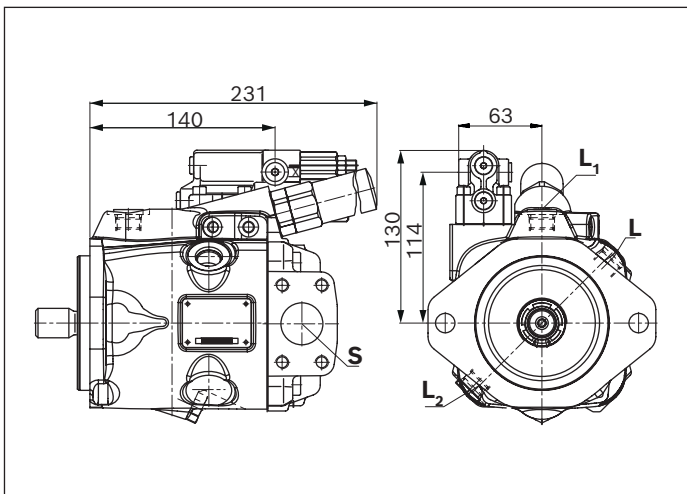

▼ **ED7. / ER7. – Electro-prop. pressure control, series 53**

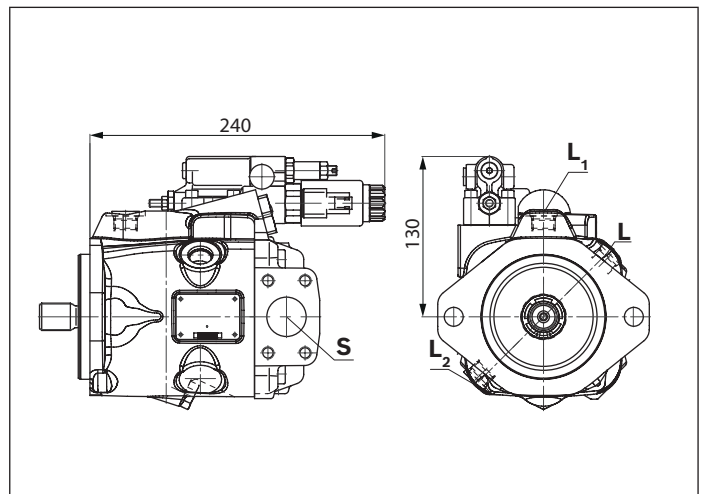

Dimensions, size 45

DRG – hydraulic pressure controller, with pressure cut-off, remote controlled, clockwise rotation, series 52

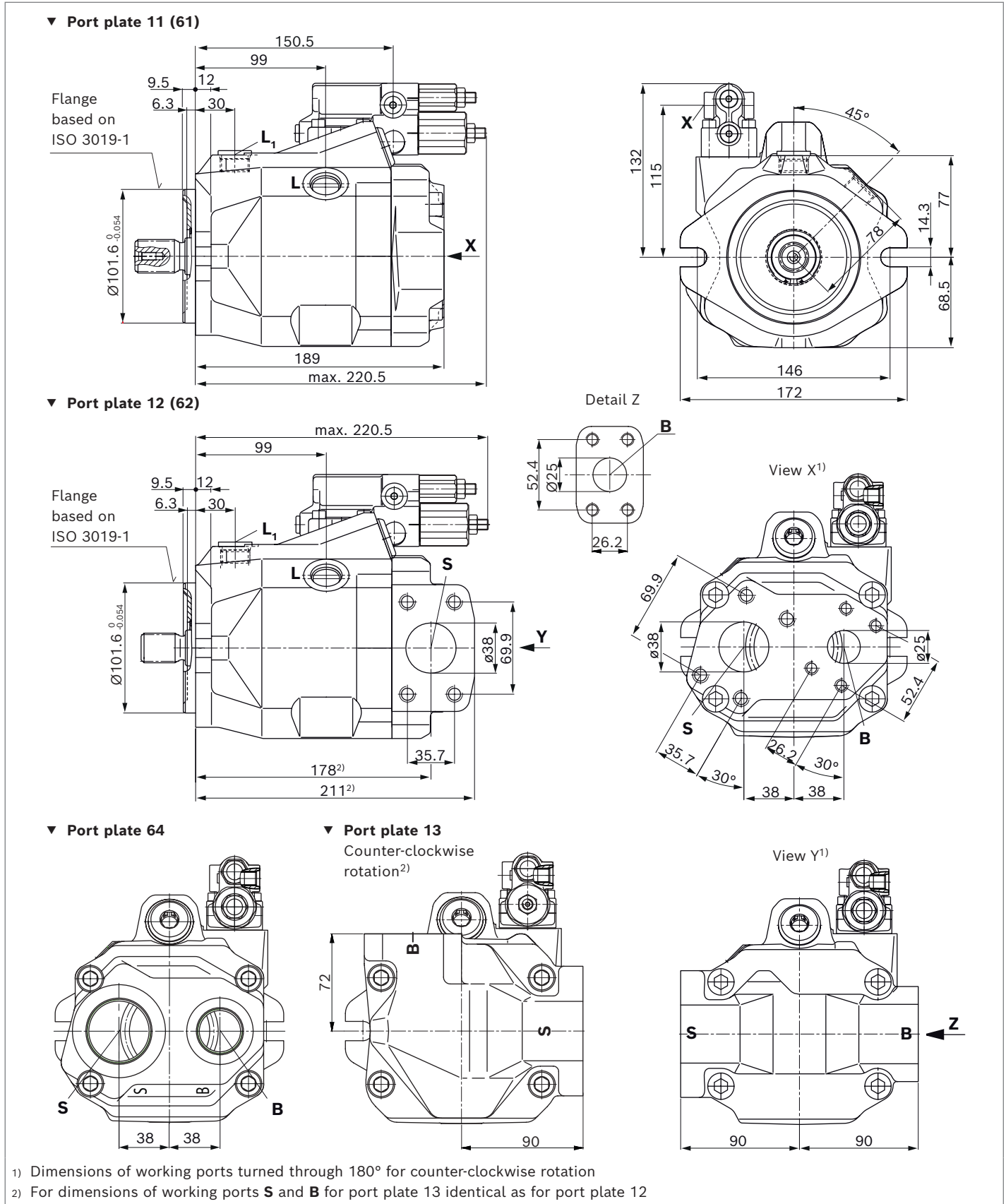

Dimensions, size 45

DRG – hydraulic pressure controller, with pressure cut-off, remote controlled, clockwise rotation, series 53

▼ **Port plate 11 (61)**

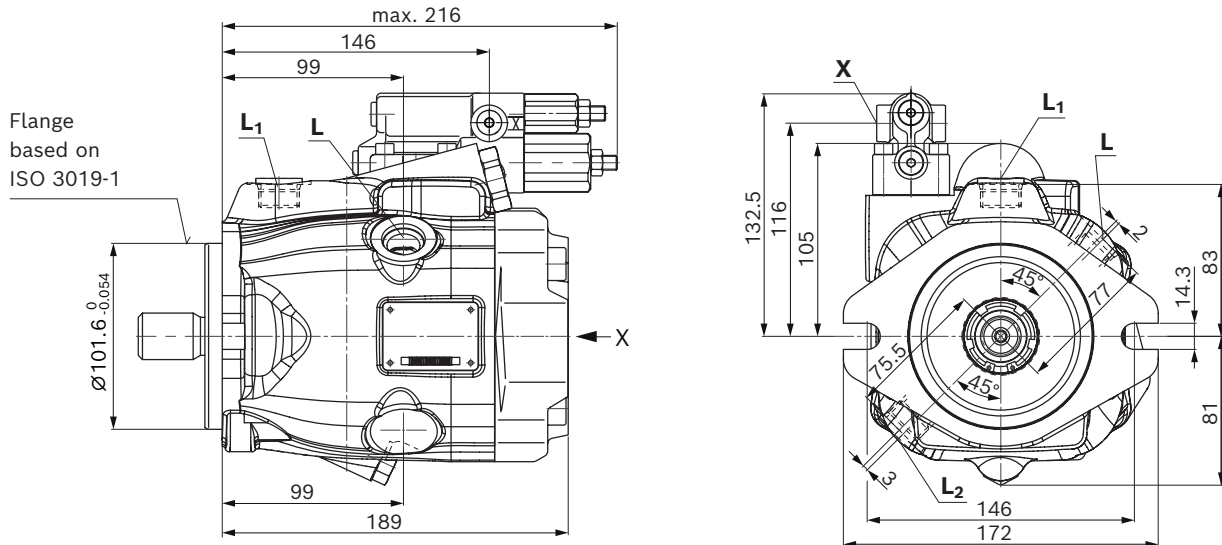

▼ **Port plate 12 (62)**

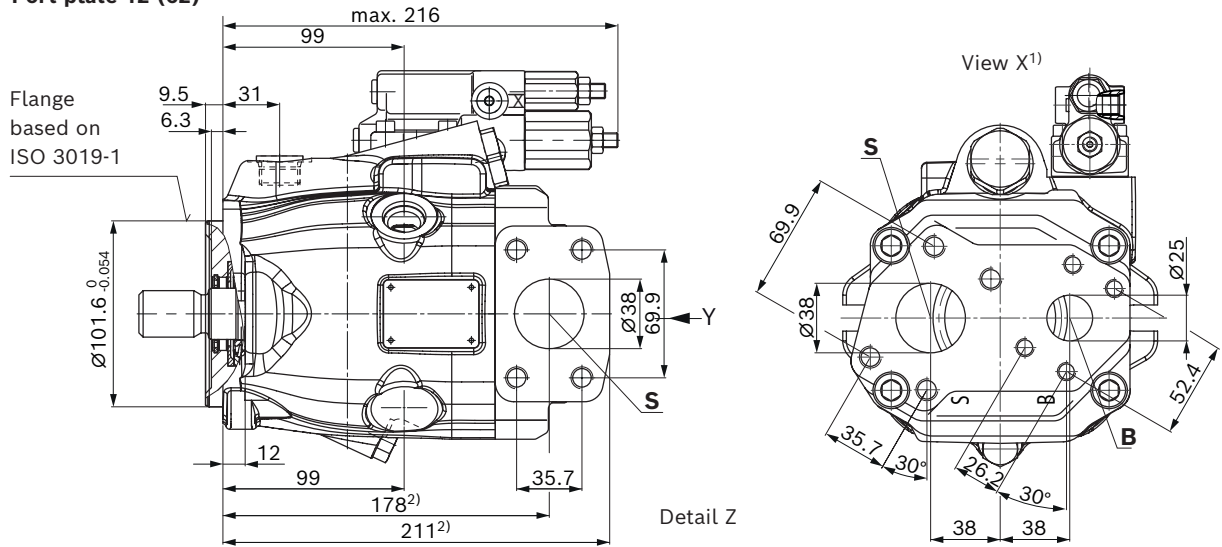

▼ **Port plate 13**
 Counter-clockwise rotation²⁾

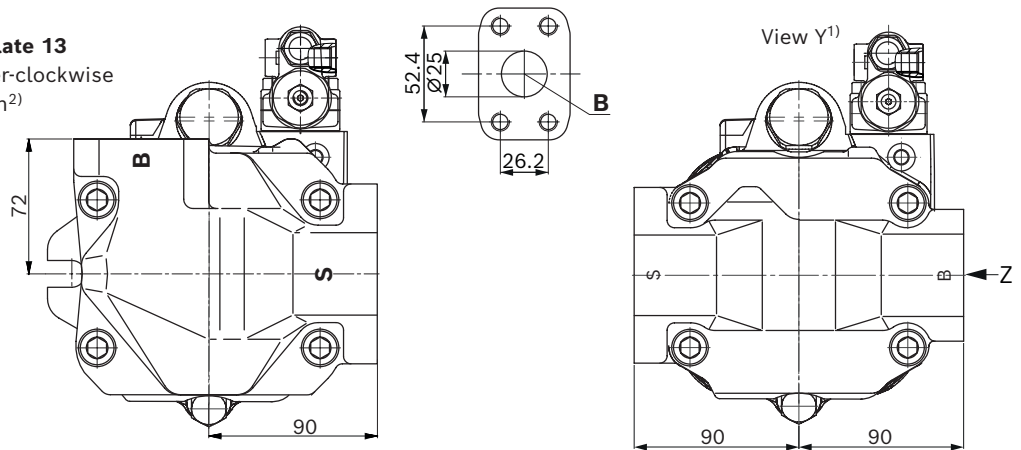

1) Dimensions of working ports turned through 180° for counter-clockwise rotation
 2) For dimensions of working ports **S** and **B** for port plate 13 identical as for port plate 12

▼ **Splined shaft 1 in (25-4, ISO 3019-1)**

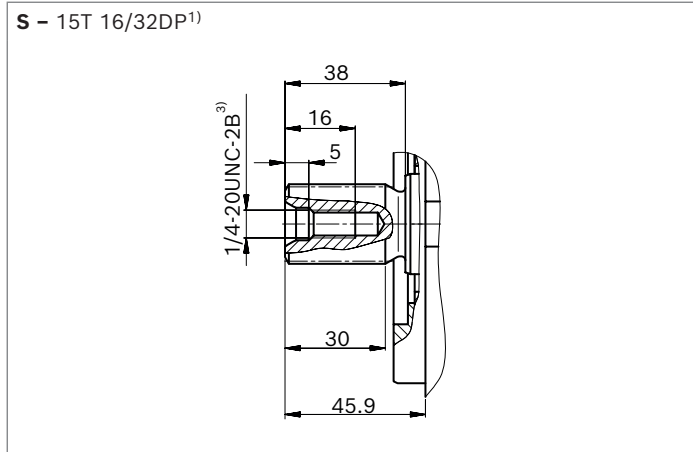

▼ **Splined shaft 1 in (similar to ISO 3019-1)**

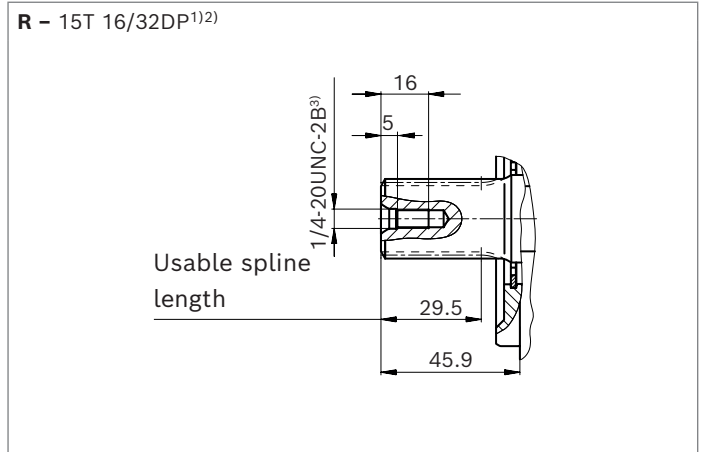

▼ **Splined shaft 7/8 in (22-4, ISO 3019-1)**

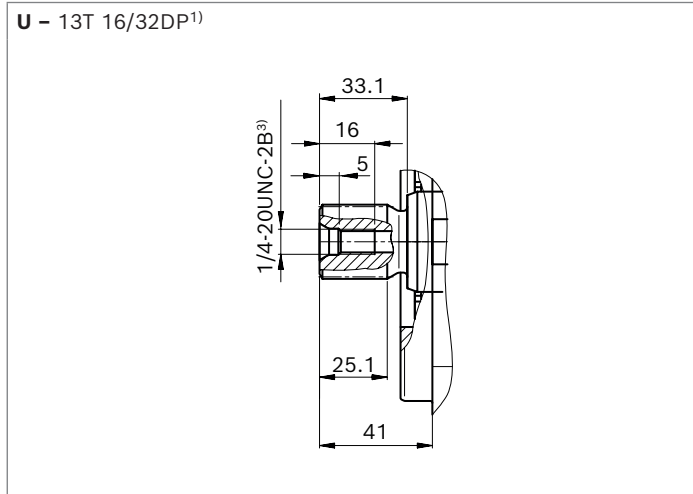

▼ **Splined shaft 7/8 in (similar to ISO 3019-1)**

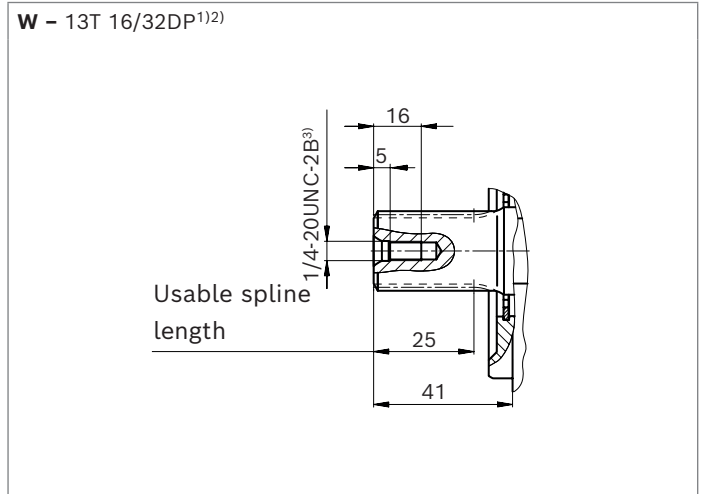

▼ **Parallel keyed shaft ISO 3019-1**

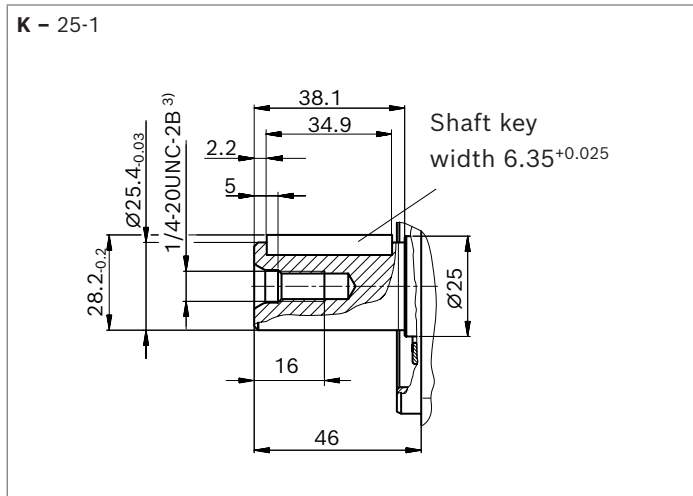

▼ **Tapered keyed shaft (ISO 3019-1)**

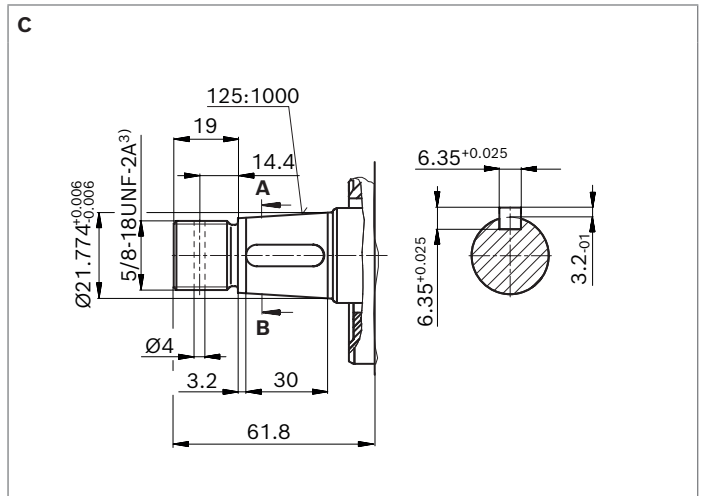

- 1) Involute spline according to ANSI B92.1a, 30° pressure angle, flat root, side fit, tolerance class 5
- 2) Splines according to ANSI B92.1a, spline runout is a deviation from standard ISO 3019-1.
- 3) Thread according to ASME B1.1

Port plate 11, 12, 13		Standard	Size	p_{\max} [bar (psi)] ¹⁾	State ⁵⁾
B	Working port (standard pressure series)	ISO 6162-1	1 in	315 (4550)	O
	Fastening thread	DIN 13	M10 × 1.5; 17 (0.67) deep		
S	Suction port (standard pressure series)	ISO 6162-1	1 1/2 in	5 (75)	O
	Fastening thread	DIN 13	M12 × 1.75; 20 (0.79) deep		
Port plate 61, 62		Standard	Size	p_{\max} [bar (psi)] ¹⁾	State ⁵⁾
B	Working port (standard pressure series)	ISO 6162-1	1 in	315 (4550)	O
	Fastening thread	ASME B1.1	3/8-16UNC-2B 18 (0.71) deep		
S	Suction port (standard pressure series)	ISO 6162-1	1 1/2 in	5 (75)	O
	Fastening thread	ASME B1.1	1/2-13 UNC-2B; 22 (0.87) deep		
Port plate 64		Standard	Size	p_{\max} [bar (psi)] ¹⁾	State ⁵⁾
B	Working port	ISO 11926	1 5/16 12UN-2B; 20 (0.79) deep	315 (4550)	O
S	Suction port	ISO 11926	1 7/8 12UN-2B; 20 (0.79) deep	5 (75)	O
Other ports		Standard	Size	p_{\max} [bar (psi)] ¹⁾	State ⁵⁾
L	Drain port	ISO 11926 ²⁾	7/8-14UNF-2B; 13 (0.51) deep	2 (30)	O ³⁾
L₁, L₂⁴⁾	Drain port	ISO 11926 ²⁾	7/8-14UNF-2B; 13 (0.51) deep	2 (30)	X ³⁾
X	Pilot pressure	ISO 11926	7/16-20UNF-2B; 11,5 (0.45) deep	315 (4550)	O

1) Depending on the application, momentary pressure peaks can occur.
Keep this in mind when selecting measuring devices and fittings.

2) The countersink may be deeper than specified in the standard.

3) Depending on the installation position, **L**, **L₁** or **L₂** must be connected (also see installation instructions starting on page 80).

4) Only for series 53

5) O = Must be connected (plugged on delivery)

X = Plugged (in normal operation)

▼ **ED7. / ER7. – Electro-prop. pressure control, series 52**

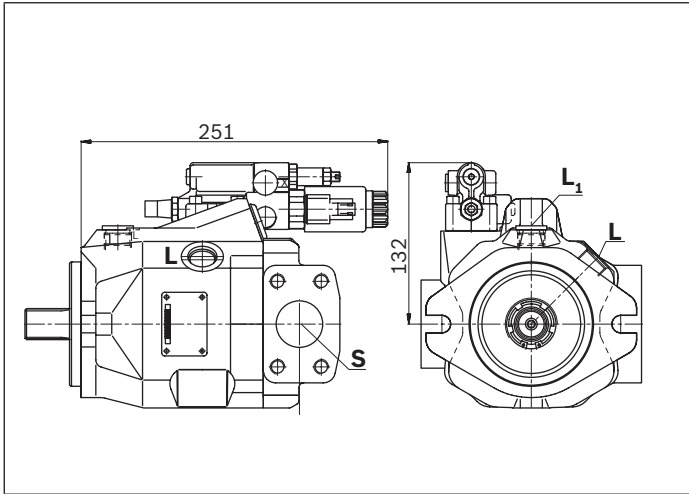

▼ **LA.D. – Pressure, flow and power controller, series 53**

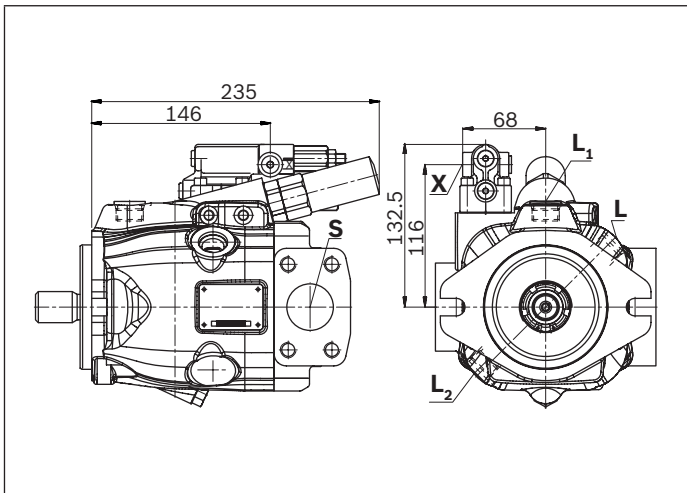

▼ **EP.D. / EK.D. – Electro proportional control, series 53**

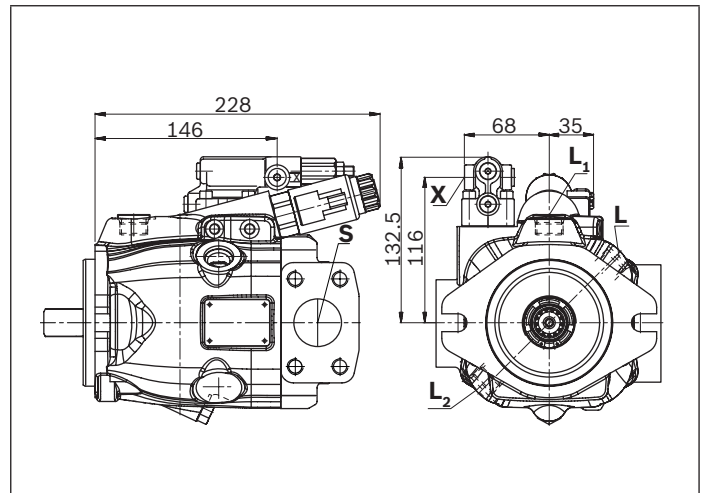

▼ **EP.ED. / EK.ED. – Electro-prop. control, series 53**

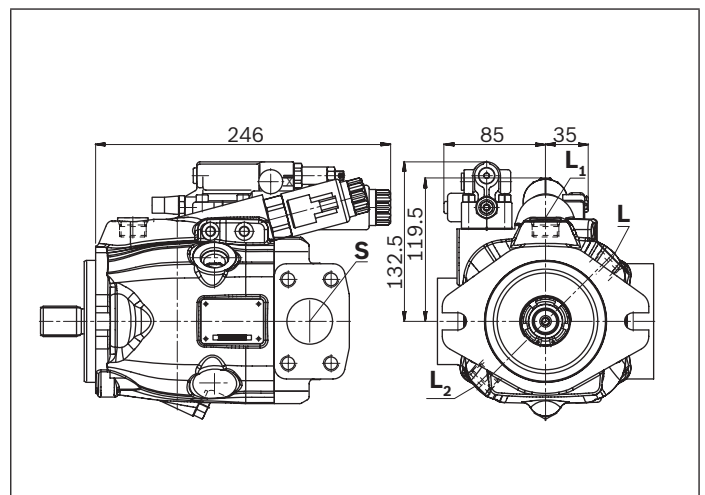

▼ **ED7. / ER7. – Electro-prop. pressure control, series 53**

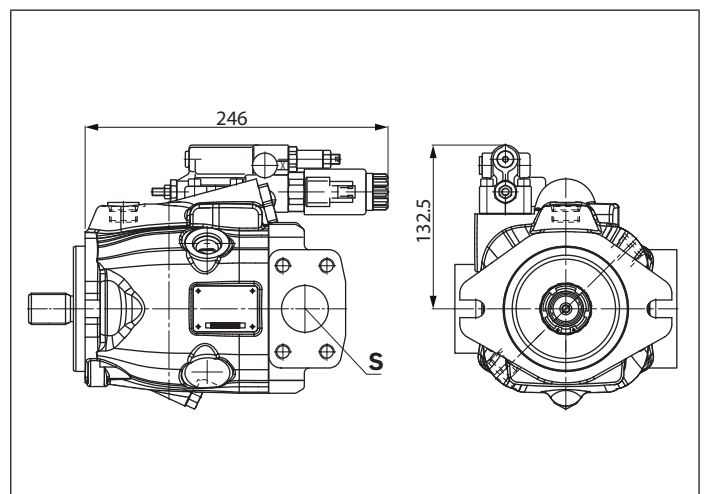

Dimensions, size 60

DR – Hydraulic pressure controller; clockwise rotation, mounting flange C series 52

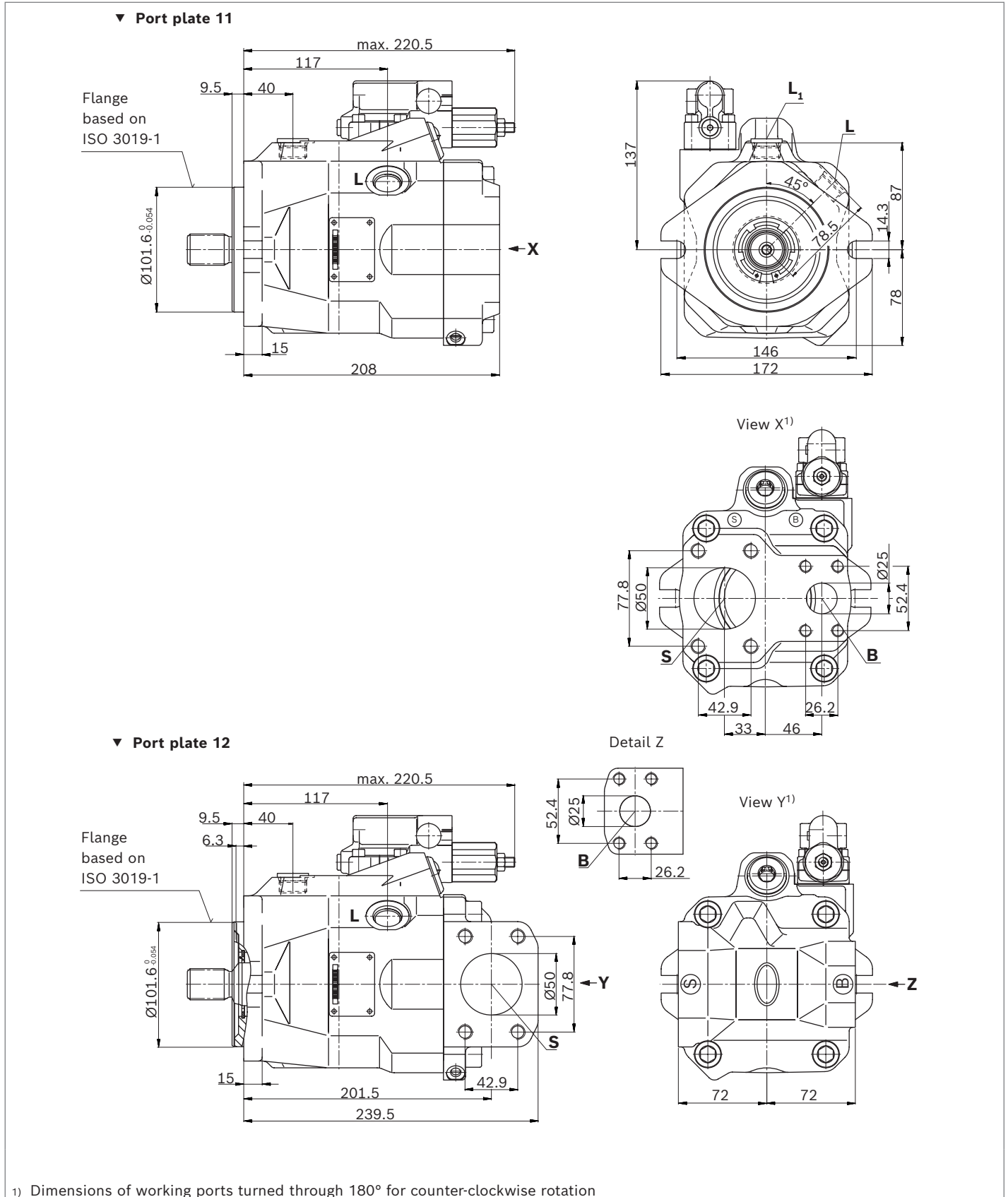

Dimensions, size 60

DR – Hydraulic pressure controller; clockwise rotation, mounting flange D series 52

▼ **Port plate 11**

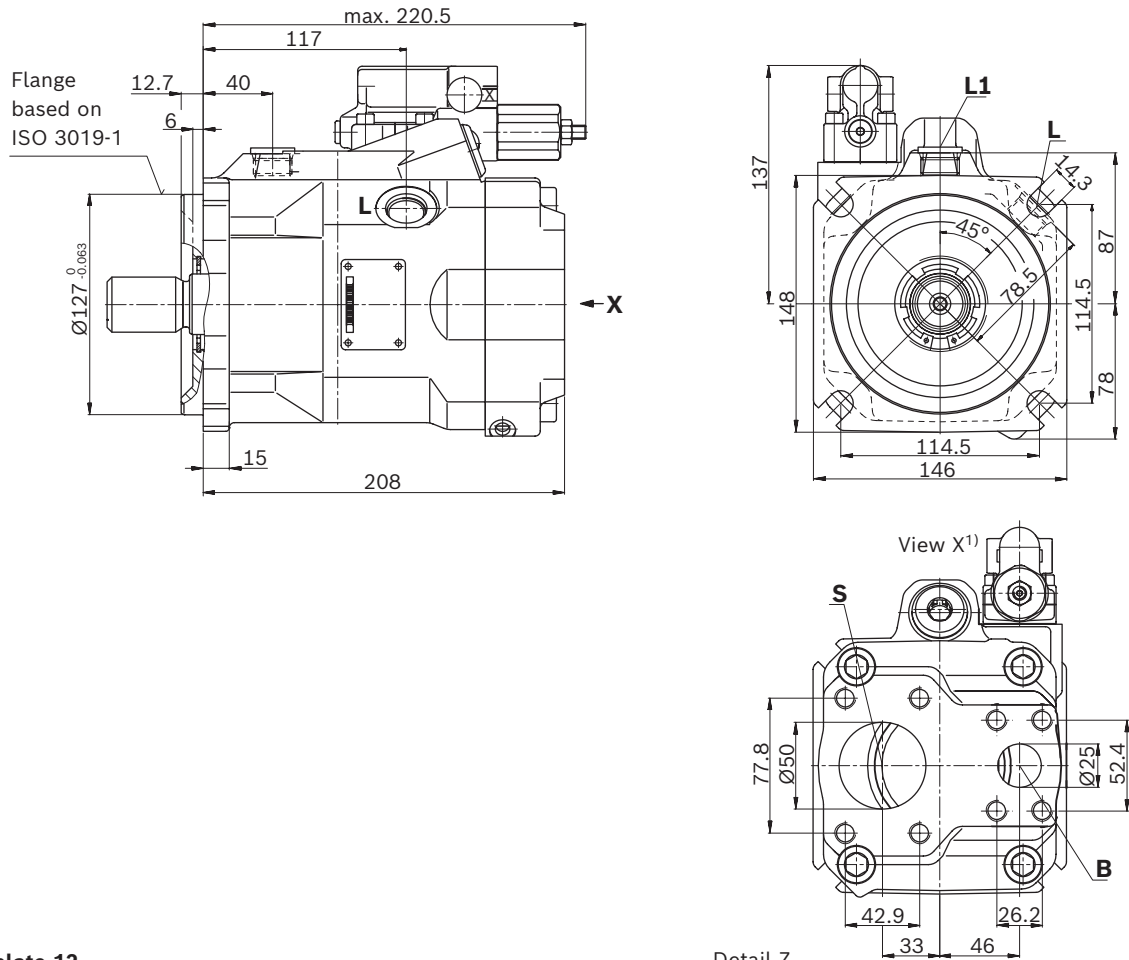

▼ **Port plate 12**

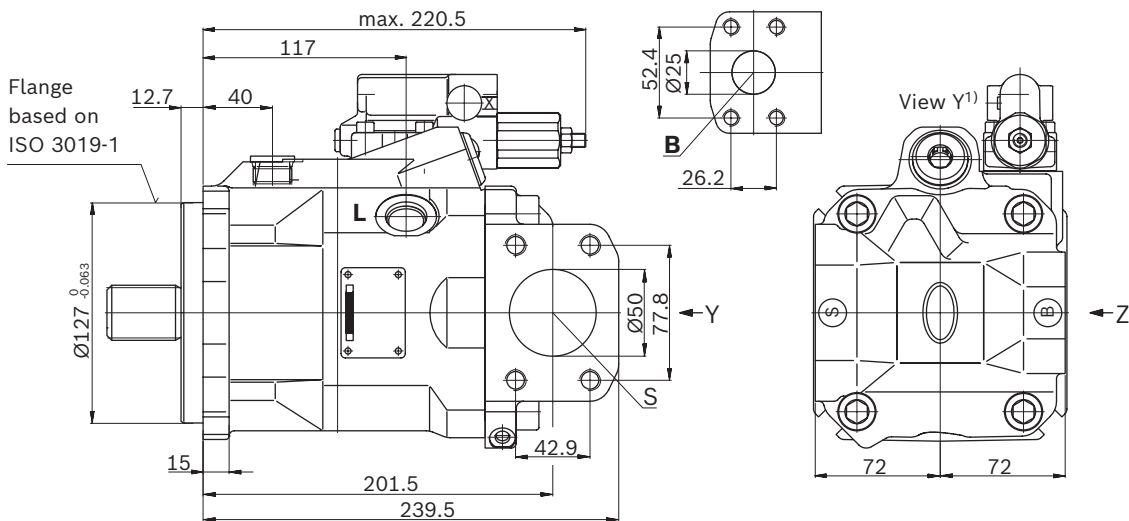

1) Dimensions of working ports turned through 180° for counter-clockwise rotation

Dimensions, size 63

DR – Hydraulic pressure controller; clockwise rotation, mounting flange C series 53

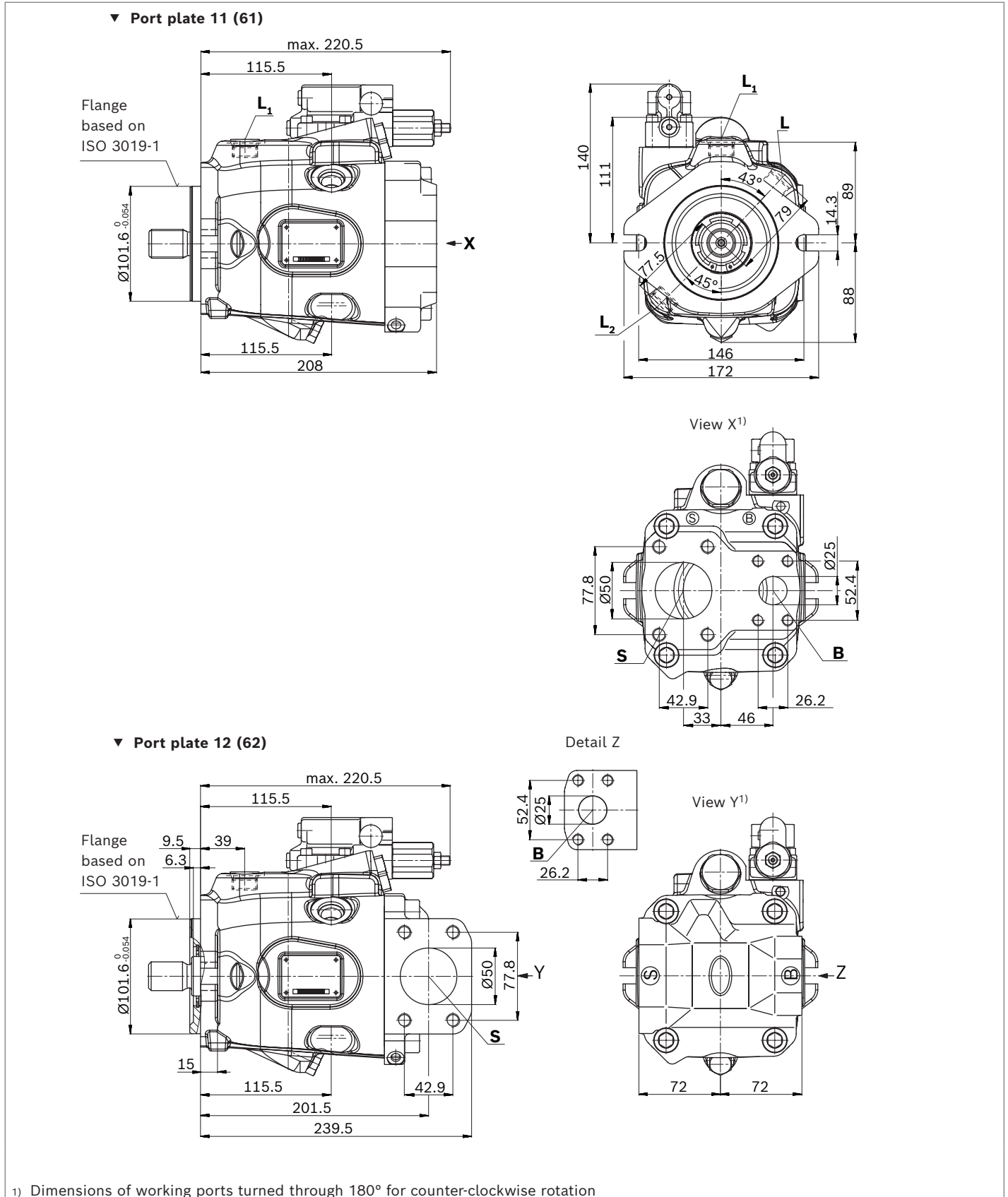

Dimensions, size 63

DR – Hydraulic pressure controller; clockwise rotation, mounting flange D series 53

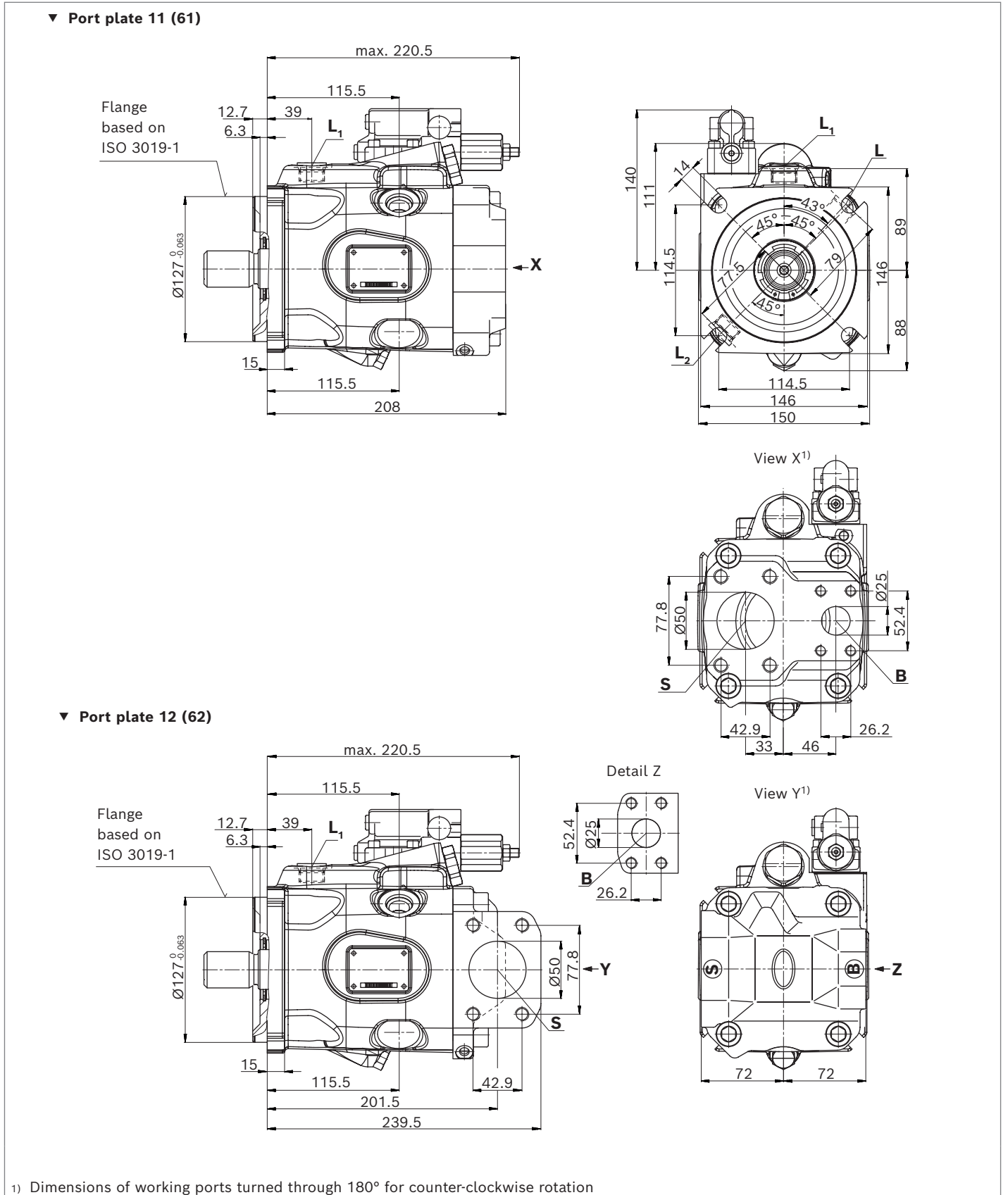

▼ **Splined shaft 1 1/4 in (32-4, ISO 3019-1)**

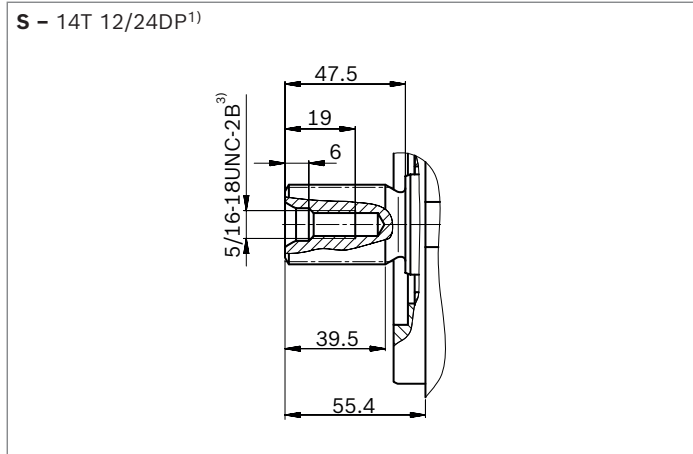

▼ **Splined shaft 1 1/4 in (similar to ISO 3019-1)**

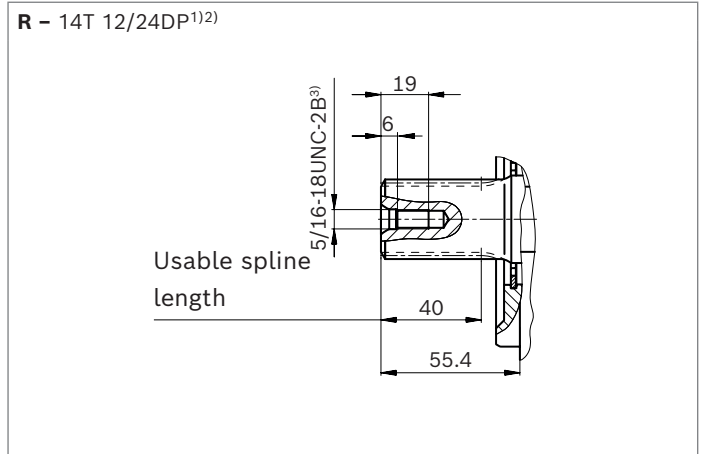

▼ **Splined shaft 1 in (25-4, ISO 3019-1)**

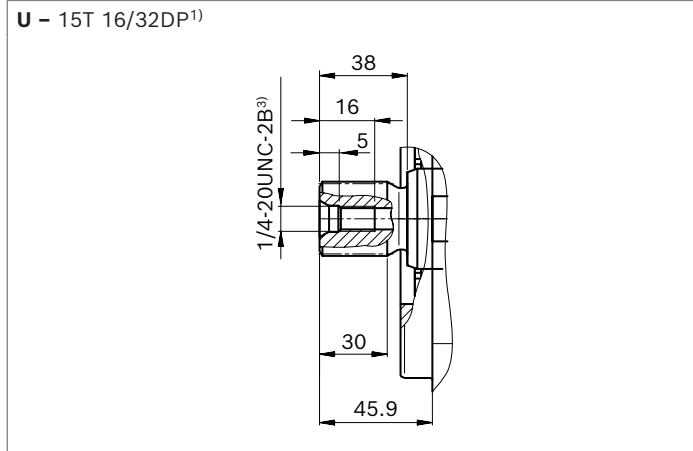

▼ **Splined shaft 1 in (similar to ISO 3019-1)**

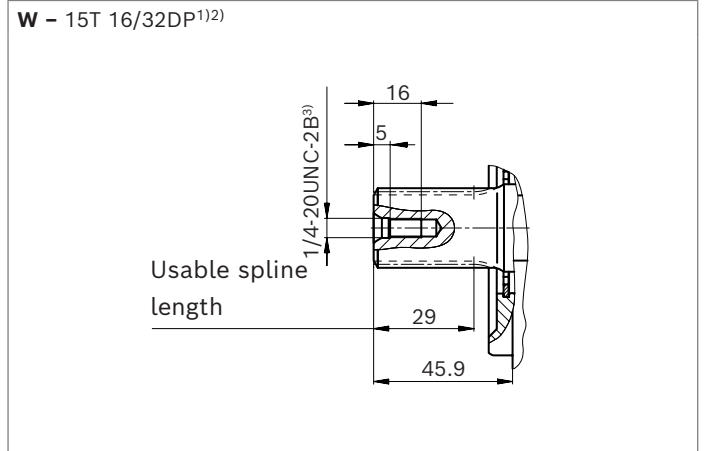

▼ **Parallel keyed shaft ISO 3019-1**

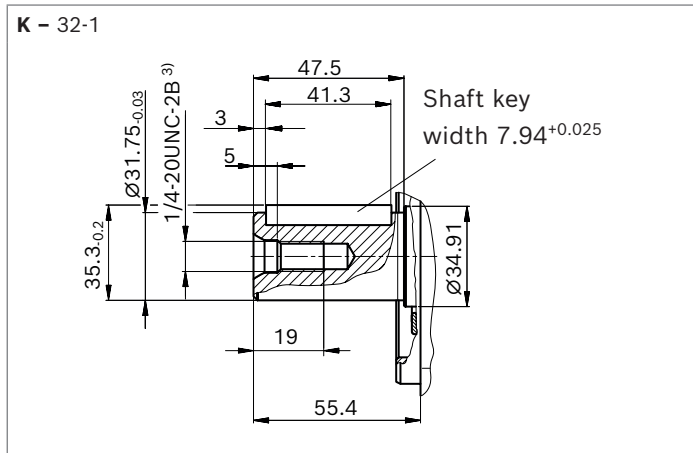

▼ **Tapered keyed shaft (ISO 3019-1)**

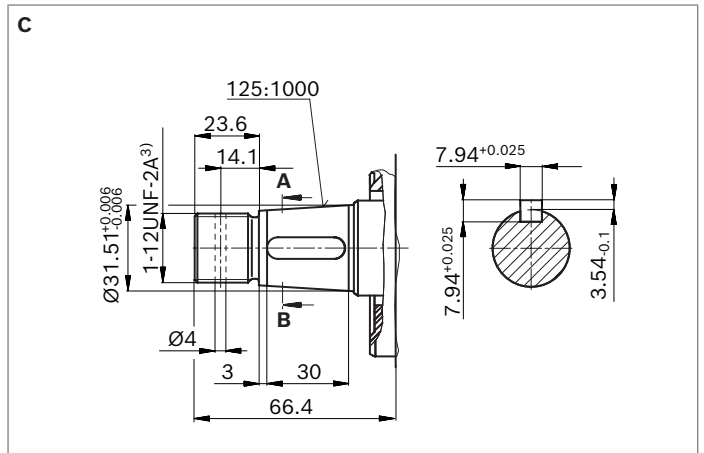

1) Involute spline according to ANSI B92.1a, 30° pressure angle, flat root, side fit, tolerance class 5
2) Splines according to ANSI B92.1a, spline runout is a deviation from standard ISO 3019-1.
3) Thread according to ASME B1.1

Port plate 11, 12		Standard	Size	p_{\max} [bar (psi)] ¹⁾	State ⁵⁾
B	Working port (standard pressure series)	ISO 6162-1	1 in	315 (4550)	O
	Fastening thread	DIN 13	M10 × 1.5; 17 deep		
S	Suction port (standard pressure series)	ISO 6162-1	2 in	5 (75)	O
	Fastening thread	DIN 13	M12 × 1.75; 20 deep		
Port plate 61, 62		Standard	Size	p_{\max} [bar (psi)] ¹⁾	State ⁵⁾
B	Working port (standard pressure series)	ISO 6162-1	1 in	315 (4550)	O
	Fastening thread	ASME B1.1	3/8-16UNC-2B; 18 (0.71) deep		
S	Suction port (standard pressure series)	ISO 6162-1	2 in	5 (75)	O
	Fastening thread	ASME B1.1	1/2-13 UNC-2B; 22 (0.87) deep		
Other ports		Standard	Size	p_{\max} [bar (psi)] ¹⁾	State ⁵⁾
L	Drain port	ISO 11926 ²⁾	7/8-14UNF-2B; 13 deep	2 (30)	O ³⁾
L₁, L₂ ⁴⁾	Drain port	ISO 11926 ²⁾	7/8-14UNF-2B; 13 deep	2 (30)	X ³⁾
X	Pilot pressure	ISO 11926	7/16-20UNF-2B; 11.5 deep	315 (4550)	O

1) Depending on the application, momentary pressure peaks can occur.
Keep this in mind when selecting measuring devices and fittings.

2) The countersink may be deeper than specified in the standard.

3) Depending on the installation position, **L**, **L₁** or **L₂** must be connected (also see installation instructions starting on page 16).

4) Only series 53

5) O = Must be connected (plugged on delivery)
X = Plugged (in normal operation)

▼ **DRG – Pressure controller, remote controlled, series 52**

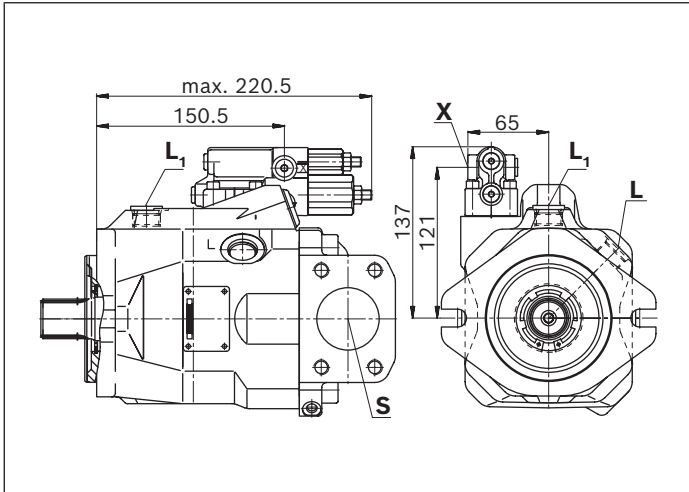

▼ **DRG – Pressure controller, remote controlled, series 53**

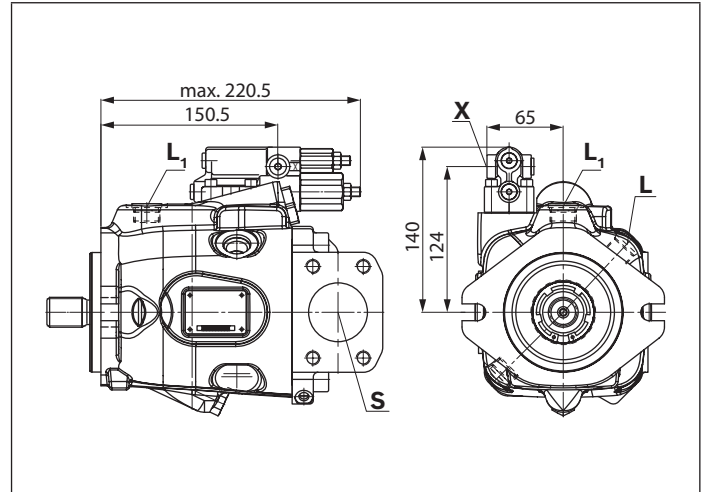

▼ **DFR/DFR1/DRSC – Pressure flow controller, series 52**

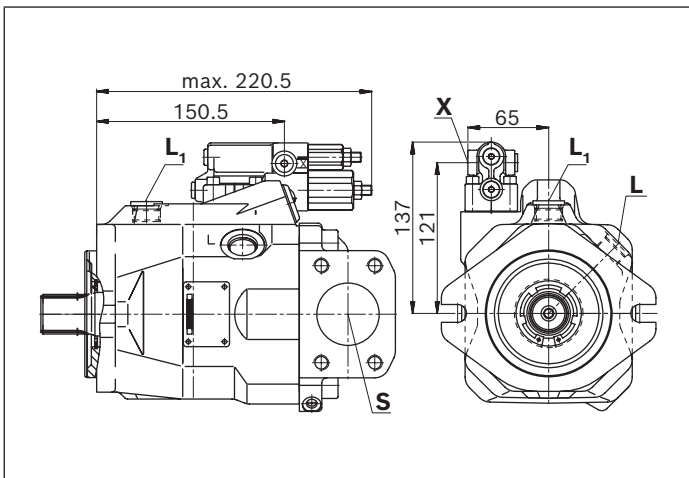

▼ **DRF/DRS/DRSC – Pressure flow controller, series 53**

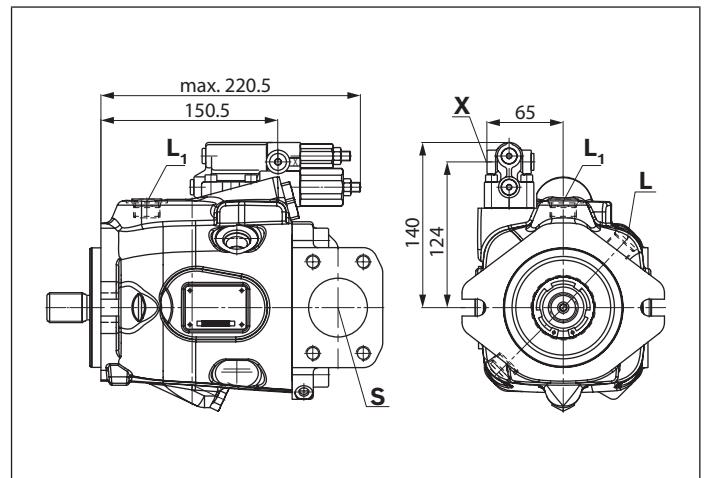

▼ **ED7-/ER7.- Electro-proportional pressure control, series 52**

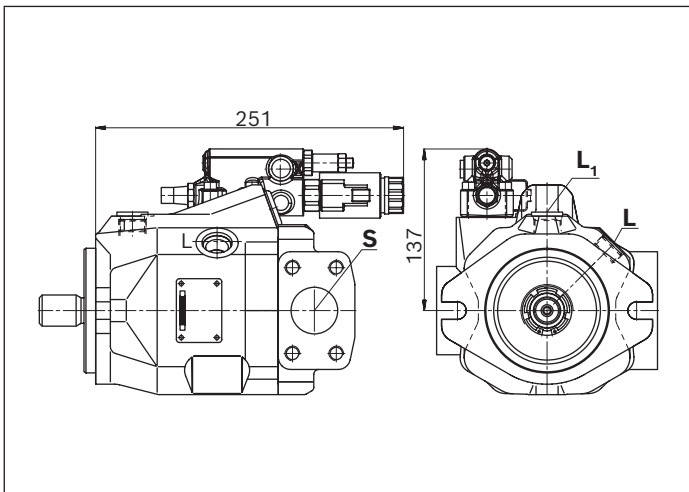

▼ **ED7-/ER7.- Electro-proportional pressure control, series 53**

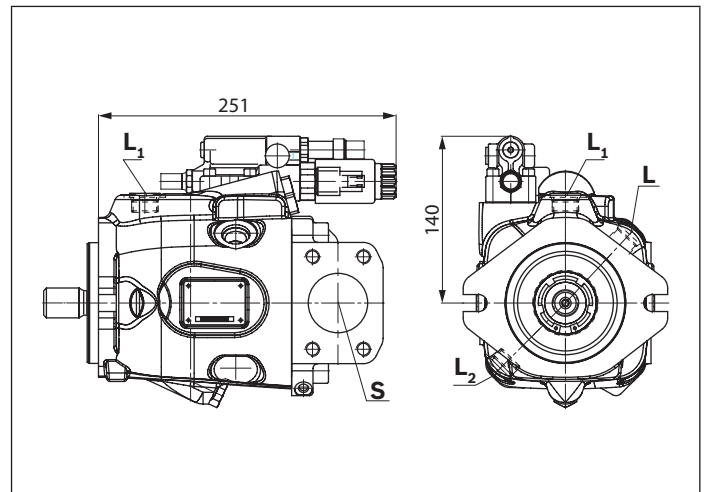

▼ **EP.D. / EK.D. - Electro proportional control, series 53**

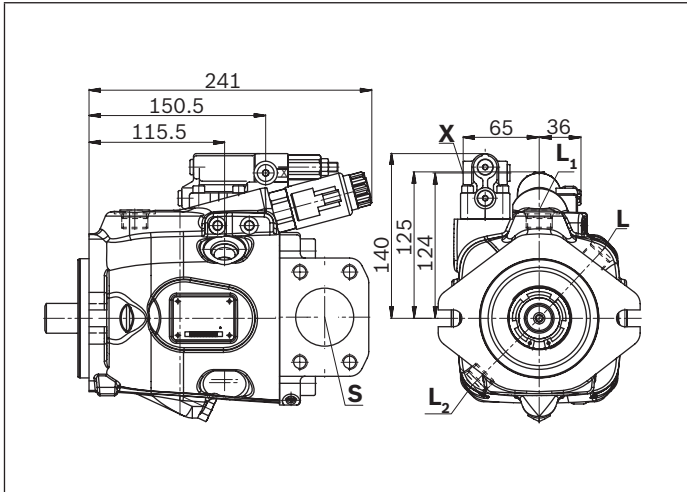

▼ **EC4 - Electro-hydraulic control valve, series 53**

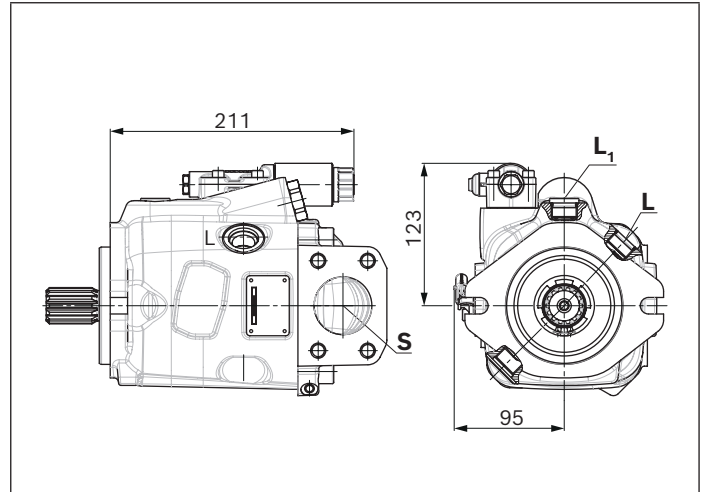

▼ **EP.ED. / EK.ED. - Electro-prop. control, series 53**

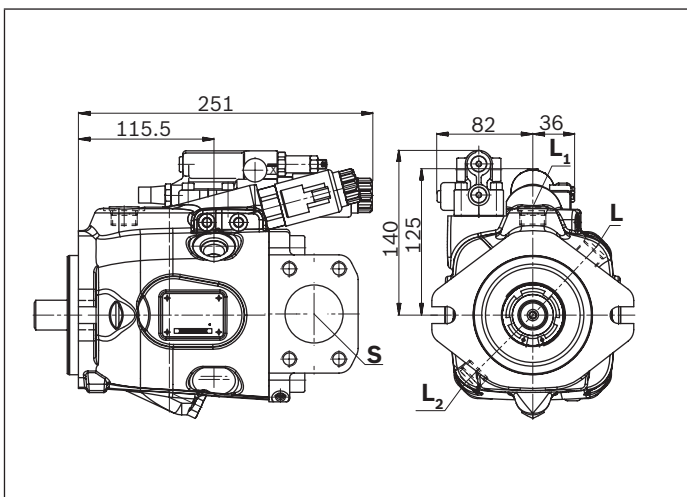

▼ **LA.D. - Pressure, flow and power controller, series 53**

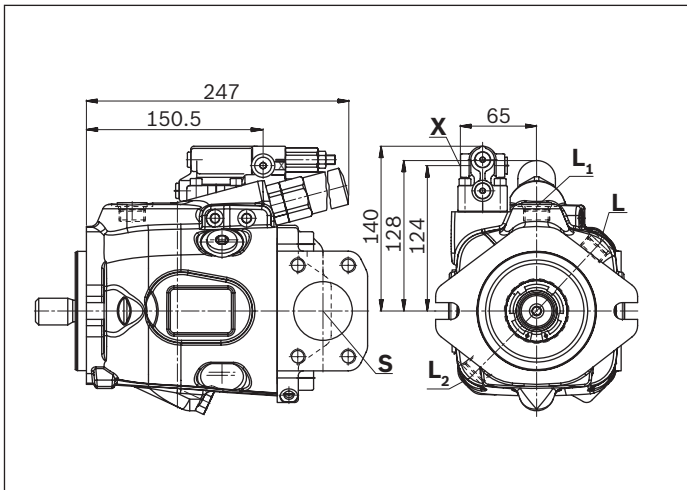

Dimensions, size 72

DR – Hydraulic pressure controller; clockwise rotation, mounting flange C series 53

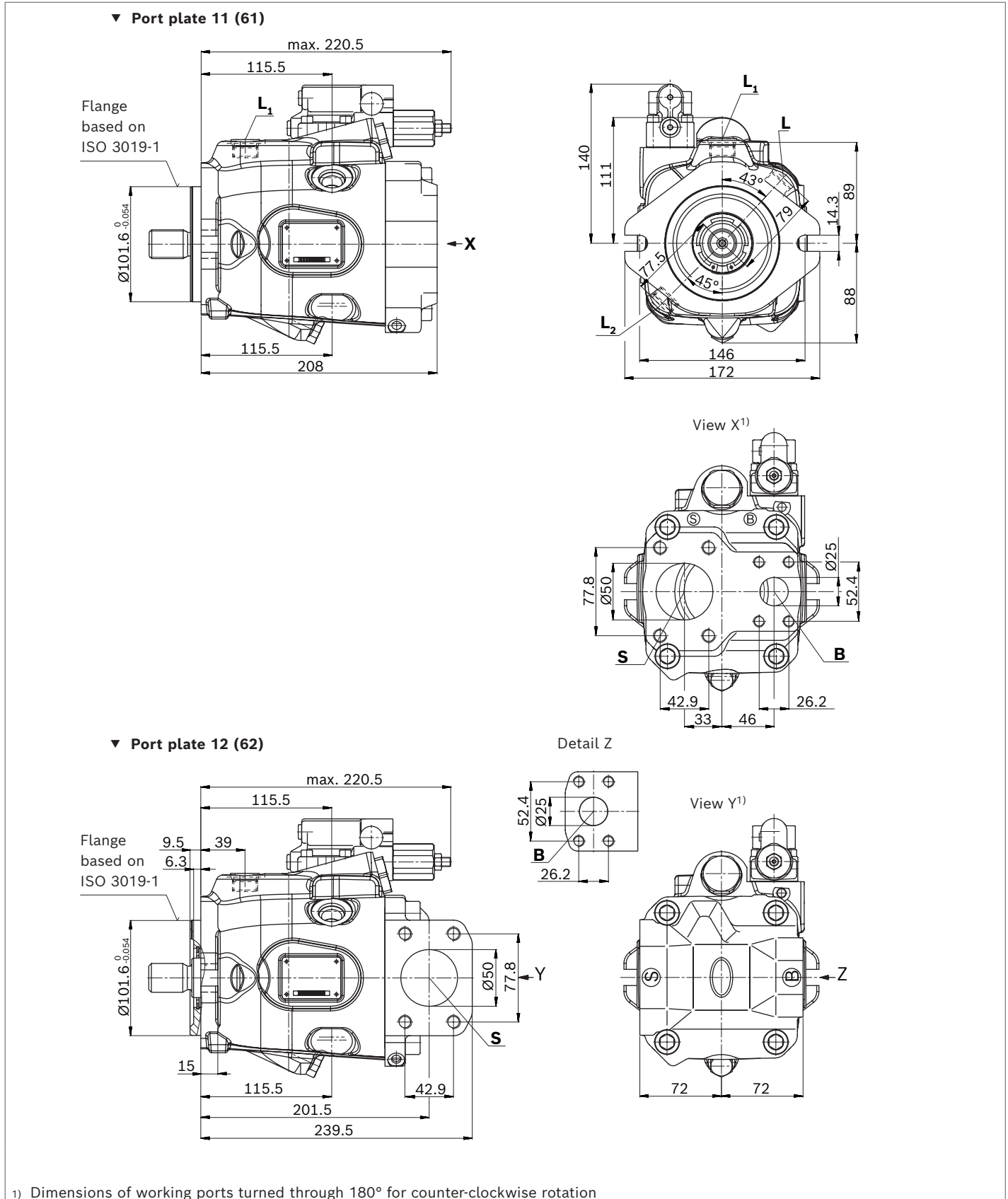

Dimensions, size 72

DR – Hydraulic pressure controller; clockwise rotation, mounting flange D series 53

▼ **Port plate 11 (61)**

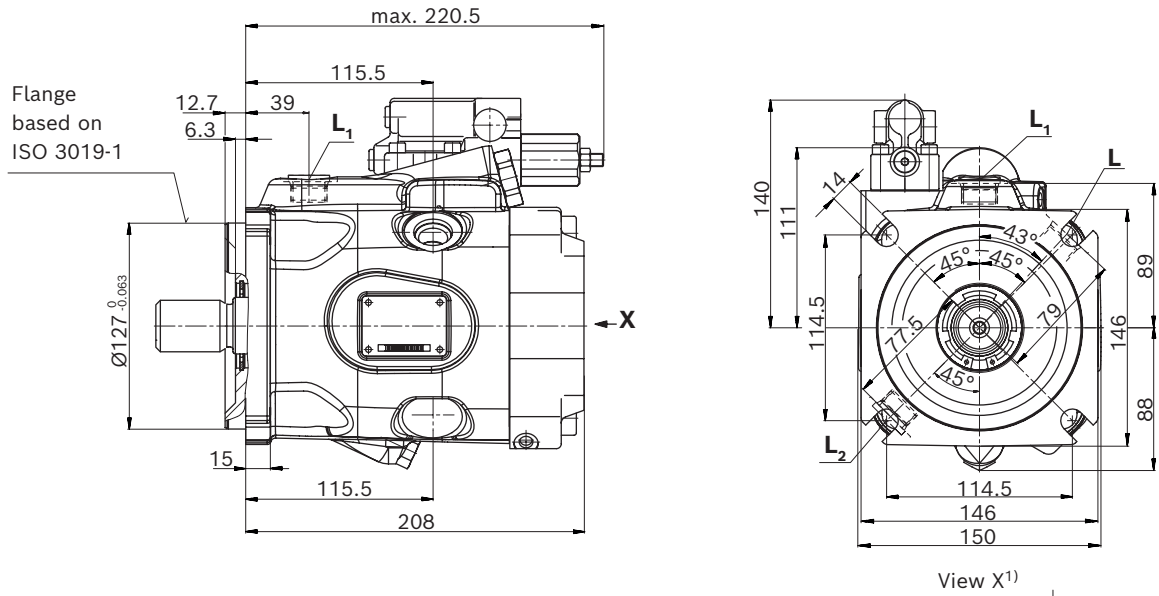

▼ **Port plate 12 (62)**

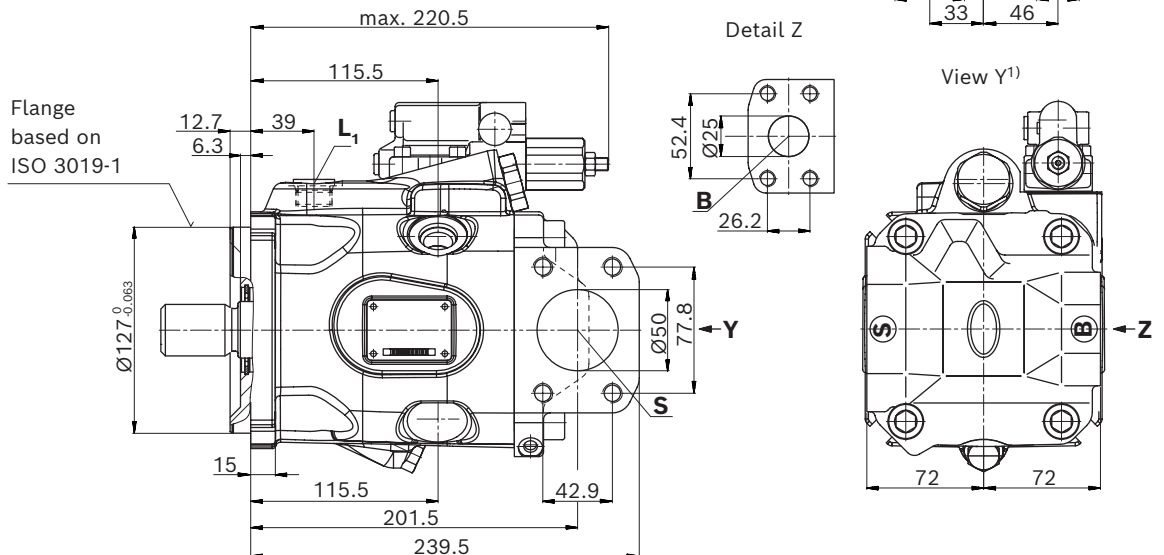

1) Dimensions of working ports turned through 180° for counter-clockwise rotation

▼ **Splined shaft 1 1/4 in (32-4, ISO 3019-1)**

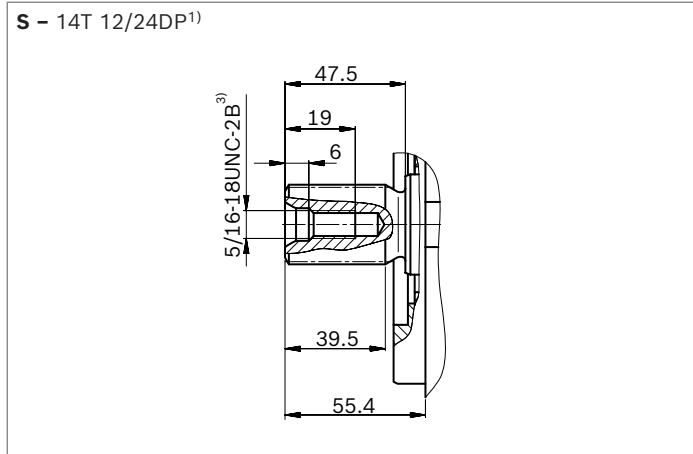

▼ **Splined shaft 1 1/4 in (similar to ISO 3019-1)**

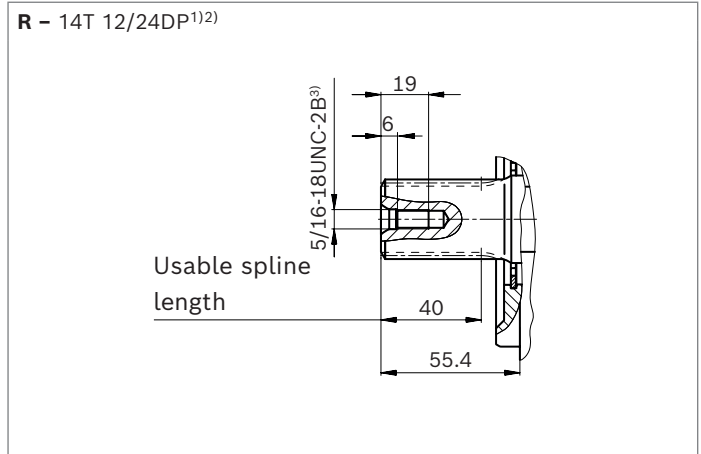

▼ **Splined shaft 1 in (25-4, ISO 3019-1)**

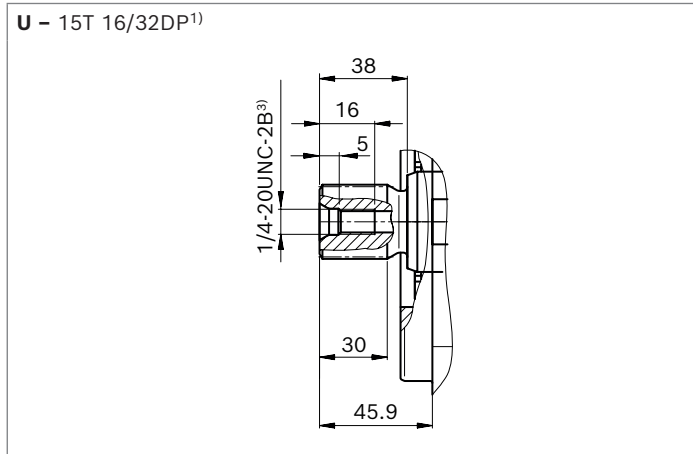

▼ **Splined shaft 1 in (similar to ISO 3019-1)**

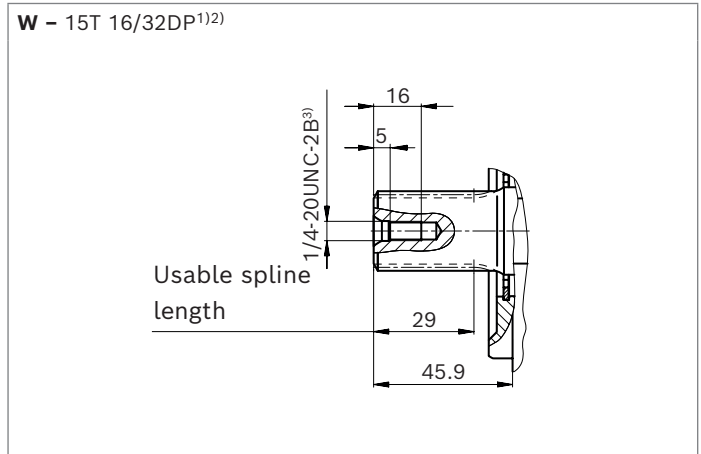

▼ **Parallel keyed shaft ISO 3019-1**

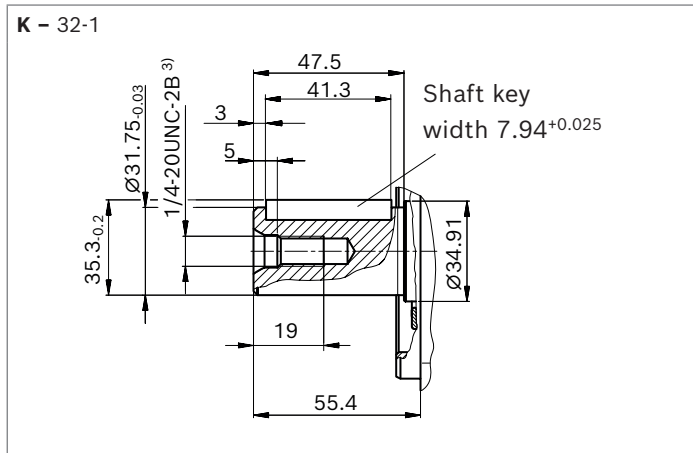

1) Involute spline according to ANSI B92.1a, 30° pressure angle, flat root, side fit, tolerance class 5
2) Splines according to ANSI B92.1a, spline runout is a deviation from standard ISO 3019-1.
3) Thread according to ASME B1.1

Port plate 11, 12		Standard	Size	p_{\max} [bar (psi)] ¹⁾	State ⁵⁾
B	Working port (standard pressure series)	ISO 6162-1	1 in	315 (4550)	O
	Fastening thread	DIN 13	M10 × 1.5; 17 (0.67) deep		
S	Suction port (standard pressure series)	ISO 6162-1	2 in	5 (75)	O
	Fastening thread	DIN 13	M12 × 1.75; 20 (0.79) deep		
Port plate 61, 62		Standard	Size	p_{\max} [bar (psi)] ¹⁾	State ⁵⁾
B	Working port (standard pressure series)	ISO 6162-1	1 in	315 (4550)	O
	Fastening thread	ASME B1.1	3/8-16UNC-2B; 18 (0.71) deep		
S	Suction port (standard pressure series)	ISO 6162-1	2 in	5 (75)	O
	Fastening thread	ASME B1.1	1/2-13 UNC-2B; 22 (0.87) deep		
Other ports		Standard	Size	p_{\max} [bar (psi)] ¹⁾	State ⁵⁾
L	Drain port	ISO 11926 ²⁾	7/8-14UNF-2B; 13 (0.51) deep	2 (30)	O ³⁾
L₁, L₂ ⁴⁾	Drain port	ISO 11926 ²⁾	7/8-14UNF-2B; 13 (0.51) deep	2 (30)	X ³⁾
X	Pilot pressure	ISO 11926	7/16-20UNF-2B; 11.5 (0.45) deep	315 (4550)	O

1) Depending on the application, momentary pressure peaks can occur.

Keep this in mind when selecting measuring devices and fittings.

2) The countersink may be deeper than specified in the standard.

3) Depending on the installation position, **L**, **L₁** or **L₂** must be connected (also see installation instructions starting on page 16).

4) Only series 53

5) O = Must be connected (plugged on delivery)

X = Plugged (in normal operation)

▼ **DRG – Pressure controller, remote controlled, series 53**

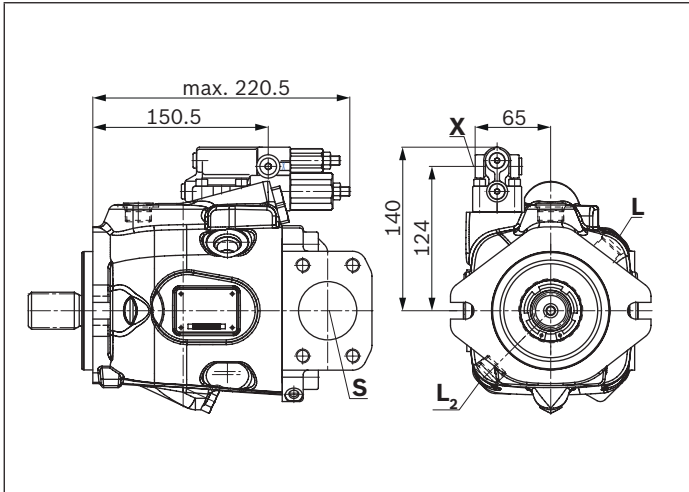

▼ **EP.D. / EK.D. – Electro proportional control, series 53**

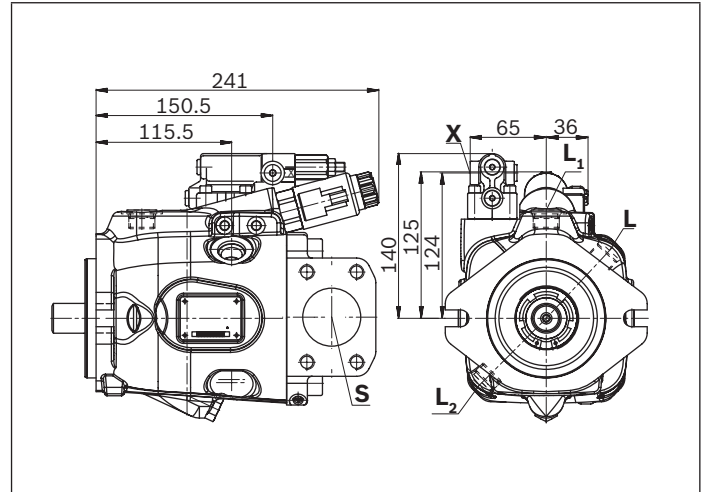

▼ **DRF/DRS/DRSC – Pressure flow controller, series 53**

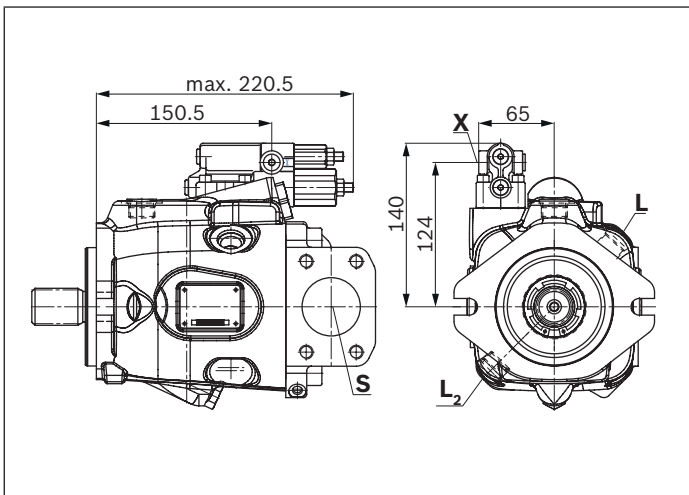

▼ **EP.ED. / EK.ED. – Electro-prop. control, series 53**

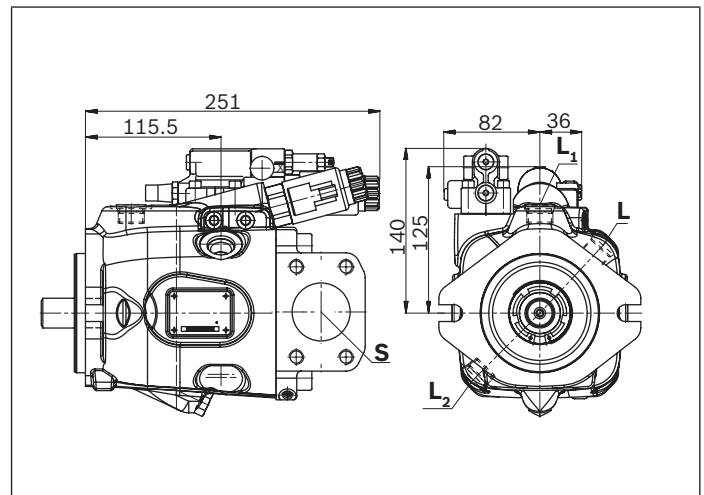

▼ **LA.D. – Pressure, flow and power controller, series 53**

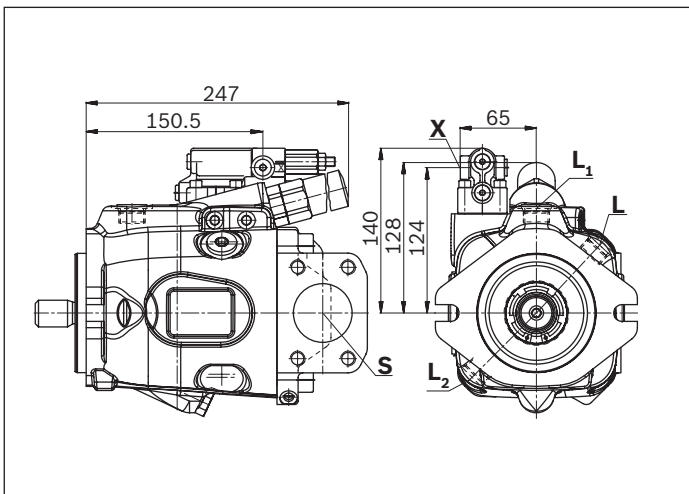

▼ **ED7. / ER7. – Electro-prop. pressure control, series 53**

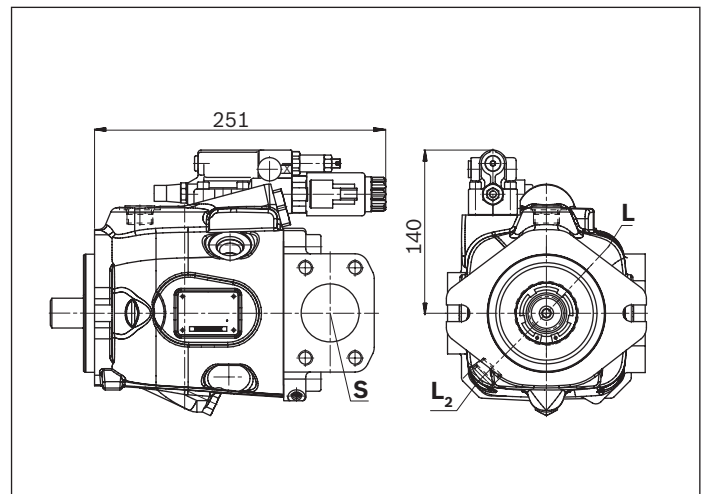

Dimensions, size 85

DR – Hydraulic pressure controller; clockwise rotation, mounting flange C series 52

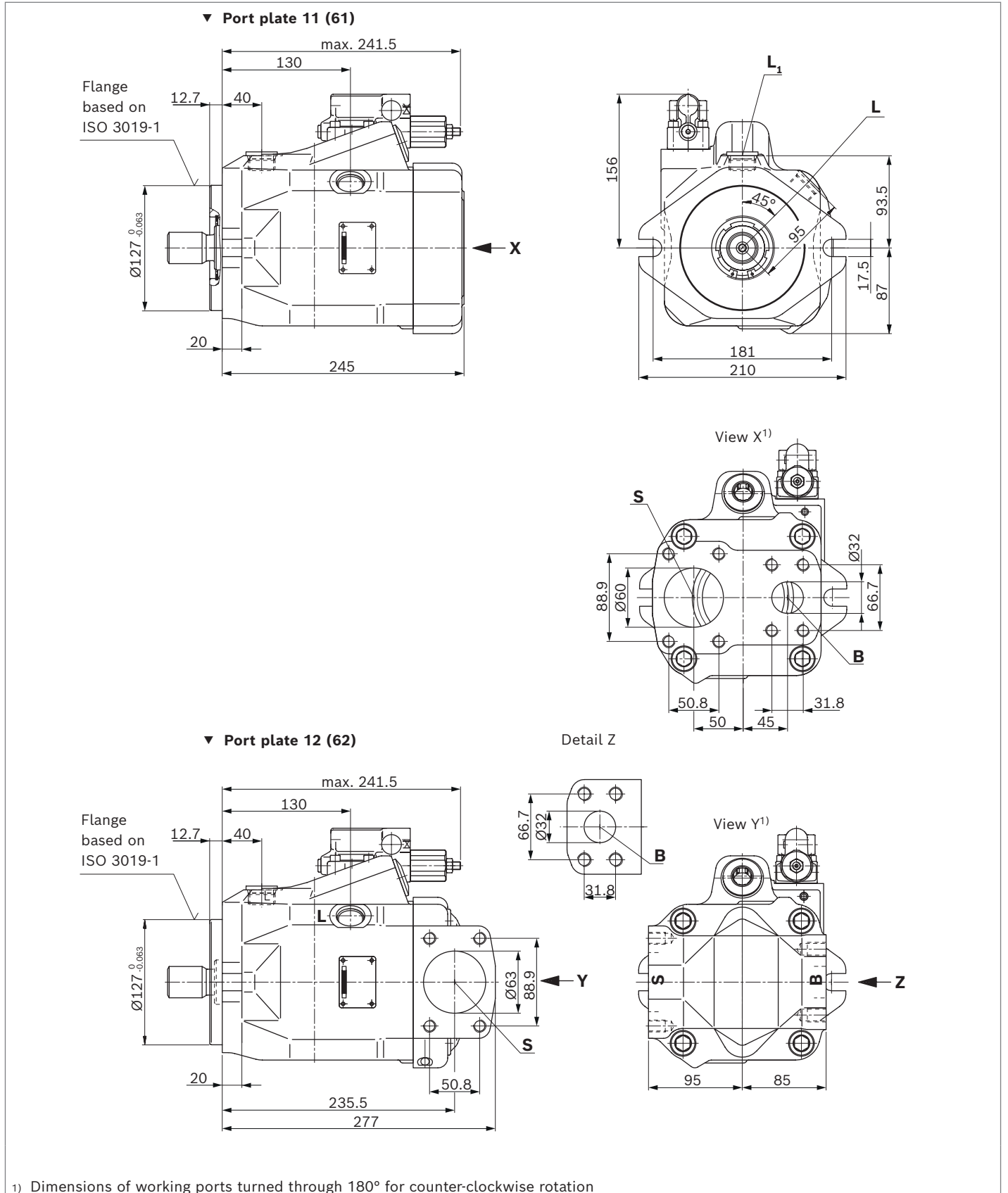

1) Dimensions of working ports turned through 180° for counter-clockwise rotation

Dimensions, size 85

DR – Hydraulic pressure controller; clockwise rotation, mounting flange C and D series 53

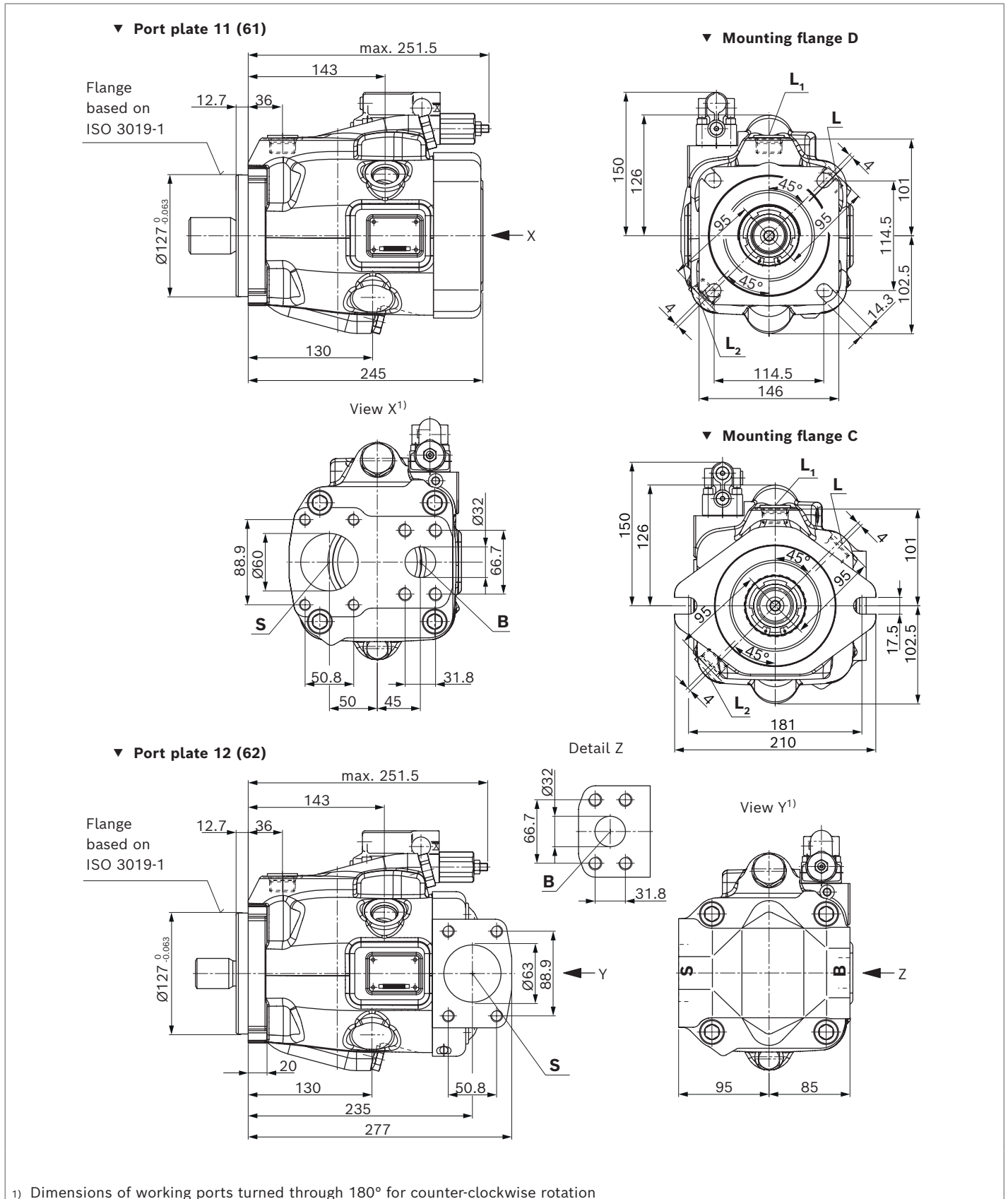

▼ Splined shaft 1 1/2 in (38-4, ISO 3019-1)

S - 17T 12/24DP¹⁾

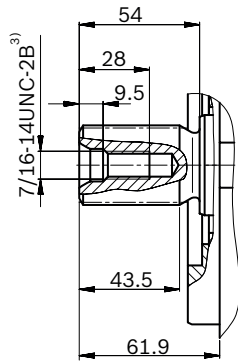

▼ Splined shaft 1 1/2 in (similar to ISO 3019-1)

R - 17T 12/24DP¹⁾²⁾

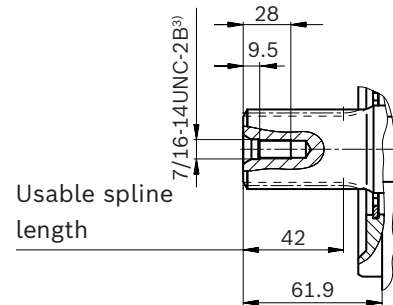

▼ Splined shaft 1 1/4 in (32-4, ISO 3019-1)

U - 14T 12/24DP¹⁾

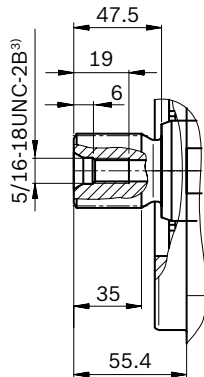

▼ Splined shaft 1 1/4 in (similar to ISO 3019-1)

W - 14T 12/24DP¹⁾²⁾

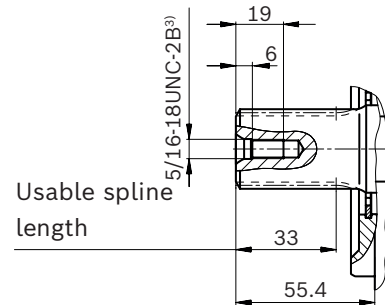

▼ Parallel keyed shaft ISO 3019-1

K - 38-1

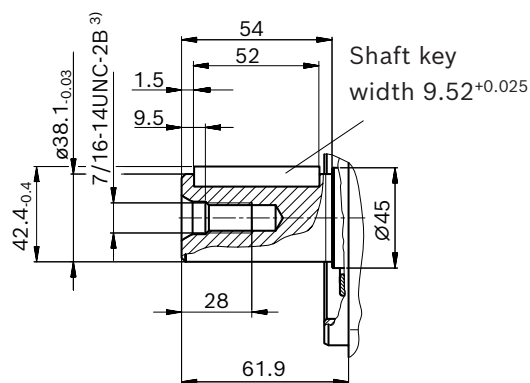

- 1) Involute spline according to ANSI B92.1a, 30° pressure angle, flat root, side fit, tolerance class 5
- 2) Splines according to ANSI B92.1a, spline runout is a deviation from standard ISO 3019-1.
- 3) Thread according to ASME B1.1

Port plate 11, 12		Standard	Size	p_{\max} [bar (psi)] ¹⁾	State ⁵⁾
B	Working port (high-pressure series)	ISO 6162-2	1 1/4 in	315 (4550)	O
	Fastening thread	DIN 13	M14 × 2; 19 (0.75) deep		
S	Suction port (standard pressure series)	ISO 6162-1	2 1/2 in	5 (75)	O
	Fastening thread	DIN 13	M12 × 1.75; 17 (0.67) deep		
Port plate 61, 62		Standard	Size	p_{\max} [bar (psi)] ¹⁾	State ⁵⁾
B	Working port (high-pressure series)	ISO 6162-2	1 1/4 in	315 (4550)	O
	Fastening thread	ASME B1.1	1/2-13UNC-2B; 19 (0.75) deep		
S	Suction port (standard pressure series)	ISO 6162-1	2 1/2 in	5 (75)	O
	Fastening thread	ASME B1.1	1/2-13UNC-2B; 27 (1.06) deep		
Other ports		Standard	Size	p_{\max} [bar (psi)] ¹⁾	State ⁵⁾
L	Drain port	ISO 11926 ²⁾	1 1/16-12UNF-2B; 15 (0.59) deep	2 (30)	O ³⁾
L₁, L₂ ⁴⁾	Drain port	ISO 11926 ²⁾	1 1/16-12UNF-2B; 15 (0.59) deep	2 (30)	X ³⁾
X	Pilot pressure	ISO 11926	7/16-20UNF-2B; 11.5 (0.45) deep	315 (4550)	O

1) Depending on the application, momentary pressure peaks can occur.
Keep this in mind when selecting measuring devices and fittings.

2) The countersink may be deeper than specified in the standard.

3) Depending on the installation position, **L**, **L₁** or **L₂** must be connected (also see installation instructions starting on page 80).

4) Only series 53

5) O = Must be connected (plugged on delivery)
X = Plugged (in normal operation)

▼ **DRG – Pressure controller, remote controlled, series 52**

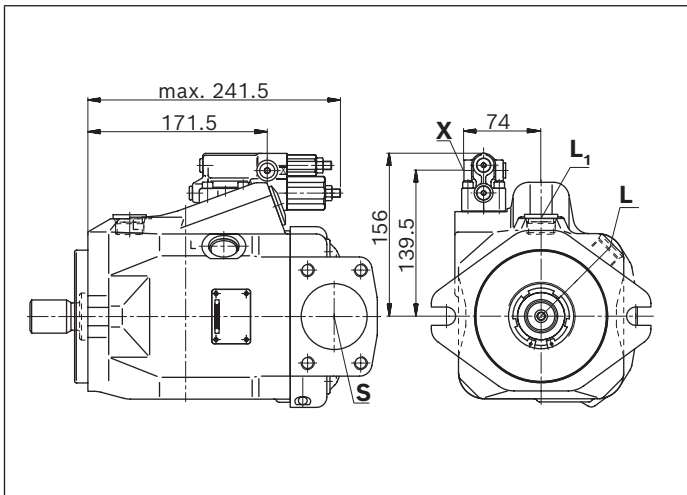

▼ **DFR/DFR1/DRSC – Pressure flow controller, series 52**

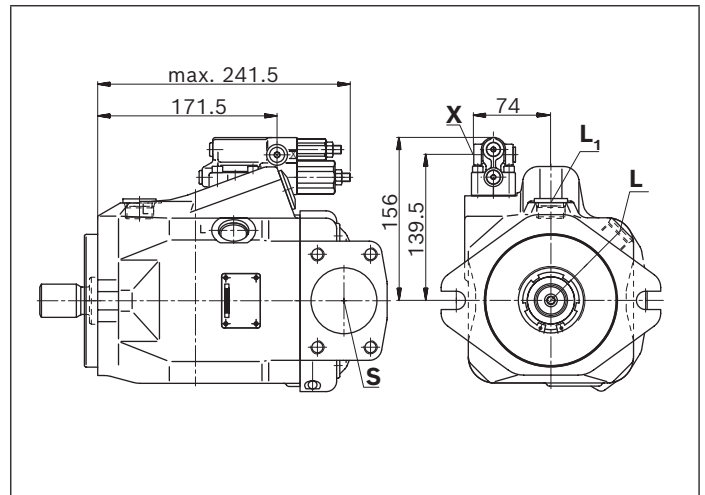

▼ **ED7. / ER7. – Electro-prop. pressure control, series 52**

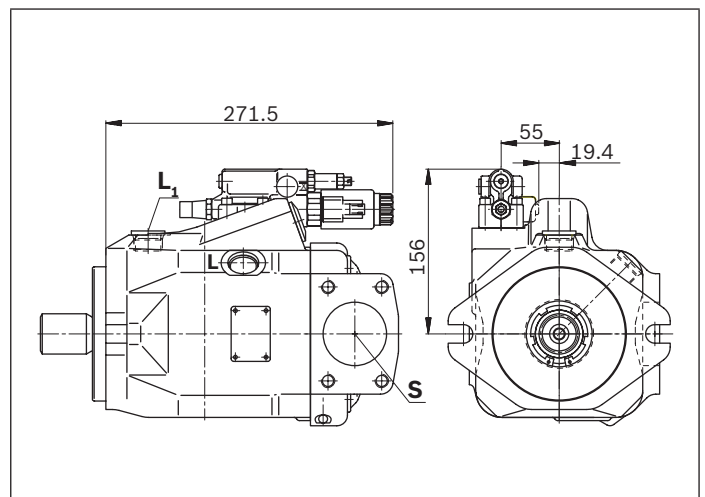

▼ **DRG – Pressure controller, remote controlled, series 53**

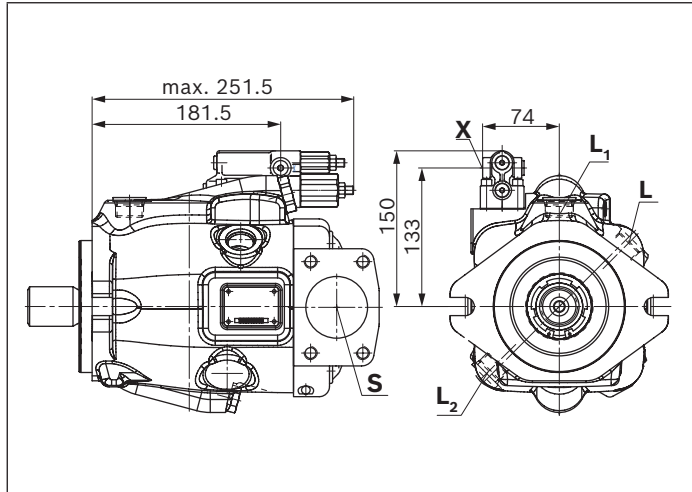

▼ **EP.D. / EK.D. – Electro proportional control, series 53**

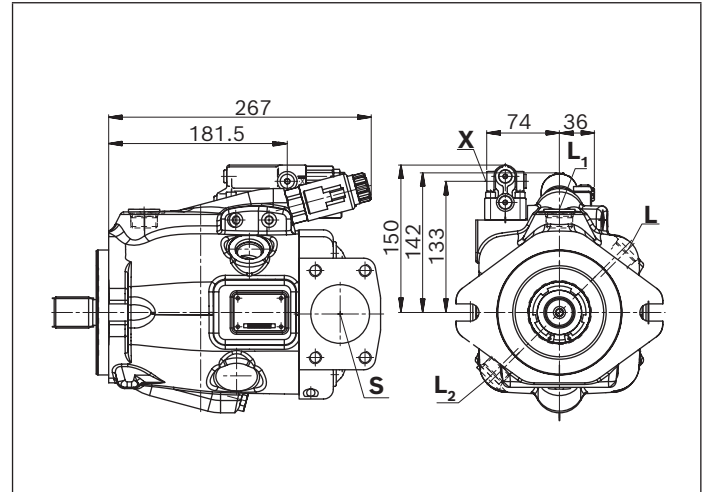

▼ **DRF/DRS/DRSC – Pressure flow controller, series 53**

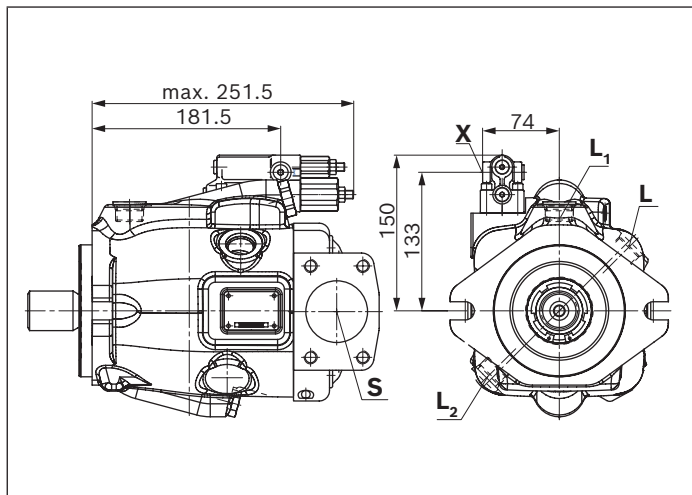

▼ **EP.ED. / EK.ED. – Electro-prop. control, series 53**

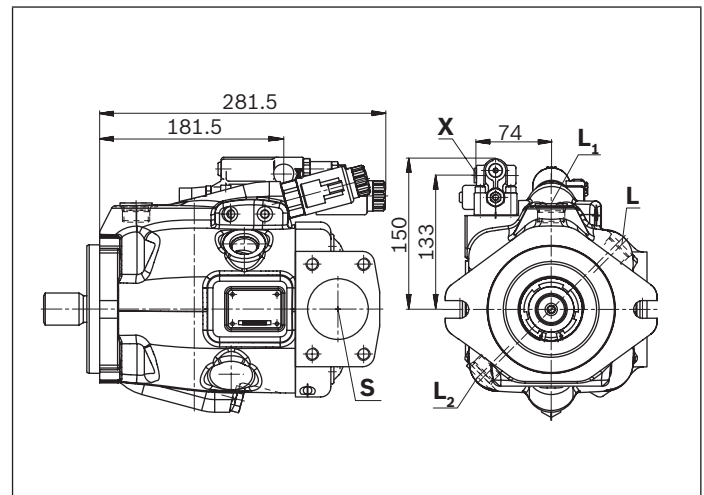

▼ **LA.D. – Pressure, flow and power controller, series 53**

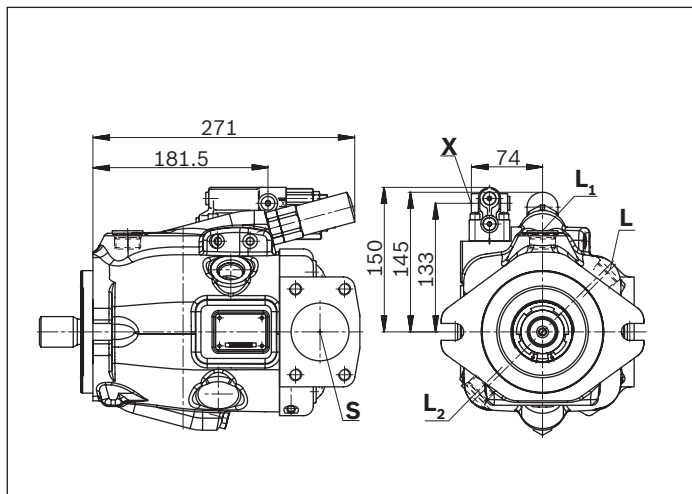

▼ **ED7. / ER7. – Electro-prop. pressure control, series 53**

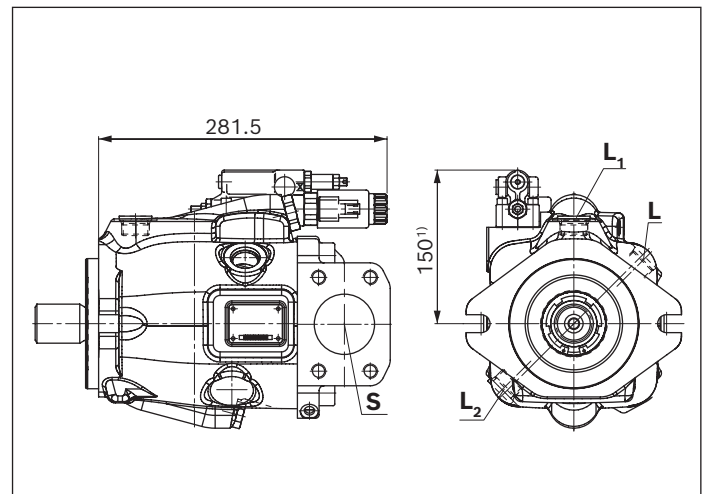

Dimensions, size 100

DR – Hydraulic pressure controller; clockwise rotation, mounting flange C series 53

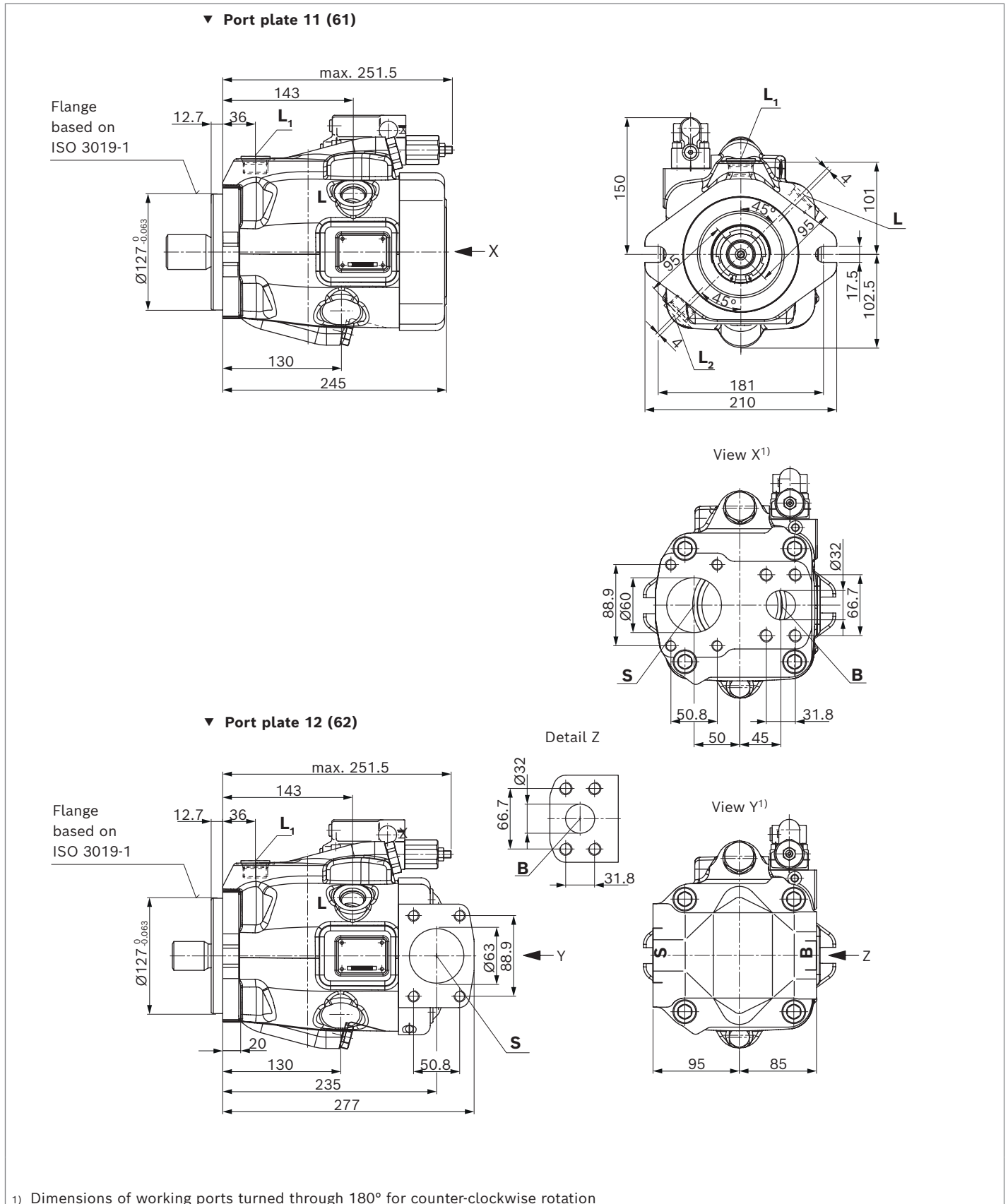

Dimensions, size 100

DR – Hydraulic pressure controller; clockwise rotation, mounting flange D series 53

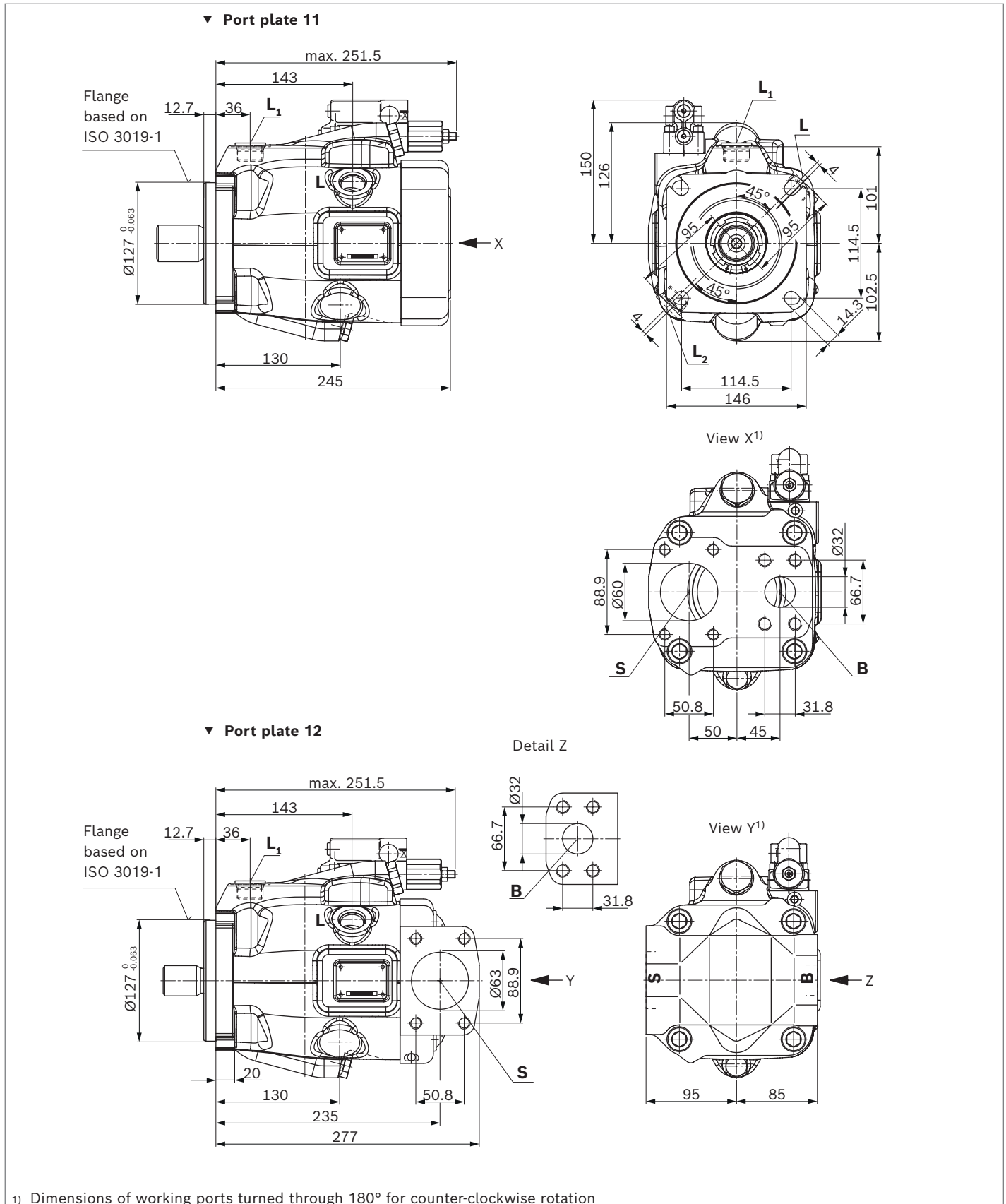

▼ **Splined shaft 1 1/2 in (38-4, ISO 3019-1)**

S - 17T 12/24DP¹⁾

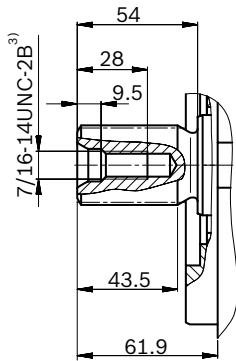

▼ **Splined shaft 1 1/2 in (similar to ISO 3019-1)**

R - 17T 12/24DP¹⁾²⁾

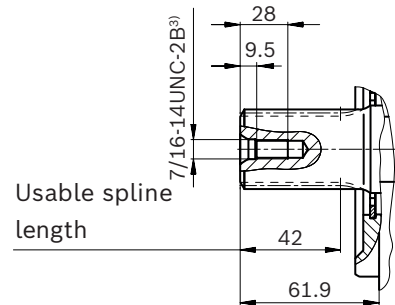

▼ **Splined shaft 1 1/4 in (32-4, ISO 3019-1)**

U - 14T 12/24DP¹⁾

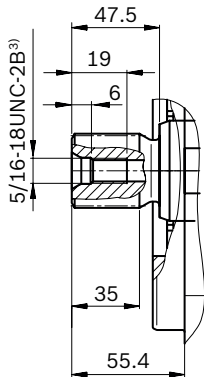

▼ **Splined shaft 1 1/4 in (similar to ISO 3019-1)**

W - 14T 12/24DP¹⁾²⁾

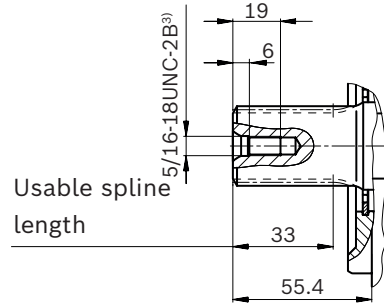

▼ **Parallel keyed shaft ISO 3019-1**

K - 38-1

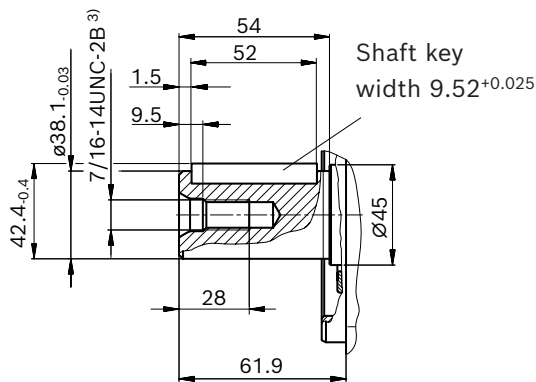

1) Involute spline according to ANSI B92.1a, 30° pressure angle, flat root, side fit, tolerance class 5
 2) Splines according to ANSI B92.1a, spline runout is a deviation from standard ISO 3019-1.
 3) Thread according to ASME B1.1

Port plate 11, 12		Standard	Size	p_{\max} [bar (psi)] ¹⁾	State ⁵⁾
B	Working port (high-pressure series)	ISO 6162-2	1 1/4 in	315 (4550)	O
	Fastening thread	DIN 13	M14 × 2; 19 (0.75) deep		
S	Suction port (standard pressure series)	ISO 6162-1	2 1/2 in	5 (75)	O
	Fastening thread	DIN 13	M12 × 1.75; 17 (0.67) deep		
Port plate 61, 62		Standard	Size	p_{\max} [bar (psi)] ¹⁾	State ⁵⁾
B	Working port (high-pressure series)	ISO 6162-2	1 1/4 in	315 (4550)	O
	Fastening thread	ASME B1.1	1/2-13UNC-2B; 19 (0.75) deep		
S	Suction port (standard pressure series)	ISO 6162-1	2 1/2 in	5 (75)	O
	Fastening thread	ASME B1.1	1/2-13UNC-2B; 27 (1.06) deep		
Other ports		Standard	Size	p_{\max} [bar (psi)] ¹⁾	State ⁵⁾
L	Drain port	ISO 11926 ²⁾	1 1/16-12UNF-2B; 15 (0.59) deep	2 (30)	O ³⁾
L₁, L₂ ⁴⁾	Drain port	ISO 11926 ²⁾	1 1/16-12UNF-2B; 15 (0.59) deep	2 (30)	X ³⁾
X	Pilot pressure	ISO 11926	7/16-20UNF-2B; 11.5 (0.45) deep	315 (4550)	O

1) Depending on the application, momentary pressure peaks can occur.
Keep this in mind when selecting measuring devices and fittings.

2) The countersink may be deeper than specified in the standard.

3) Depending on the installation position, **L**, **L₁** or **L₂** must be connected (also see installation instructions starting on page 80).

4) Only series 53

5) O = Must be connected (plugged on delivery)
X = Plugged (in normal operation)

▼ **DRG – Pressure controller, remote controlled, series 53**

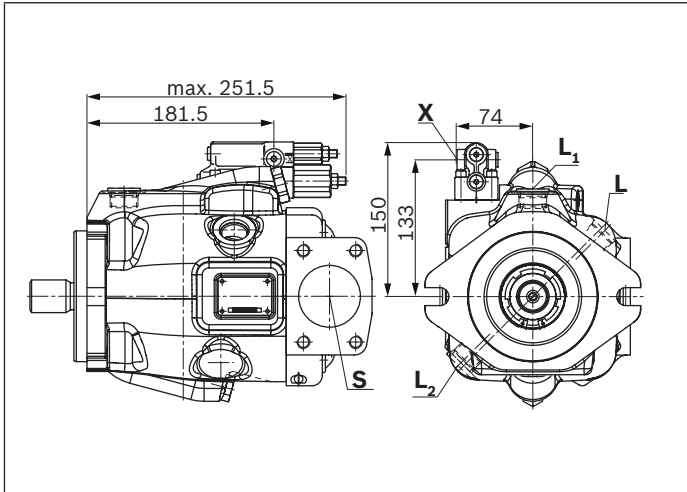

▼ **EP.D. / EK.D. – Electro proportional control, series 53**

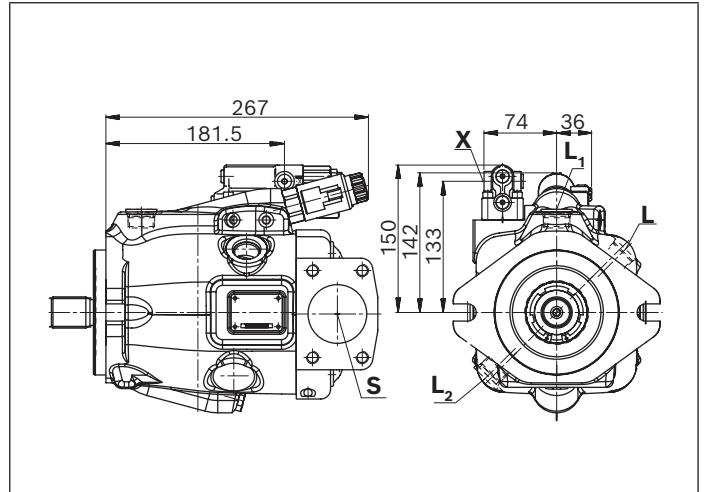

▼ **DRF/DRS/DRSC – Pressure flow controller, series 53**

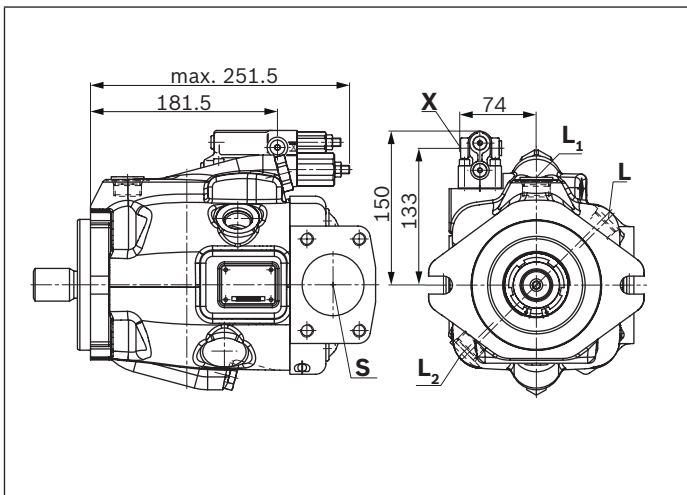

▼ **EP.ED. / EK.ED. – Electro-prop. control, series 53**

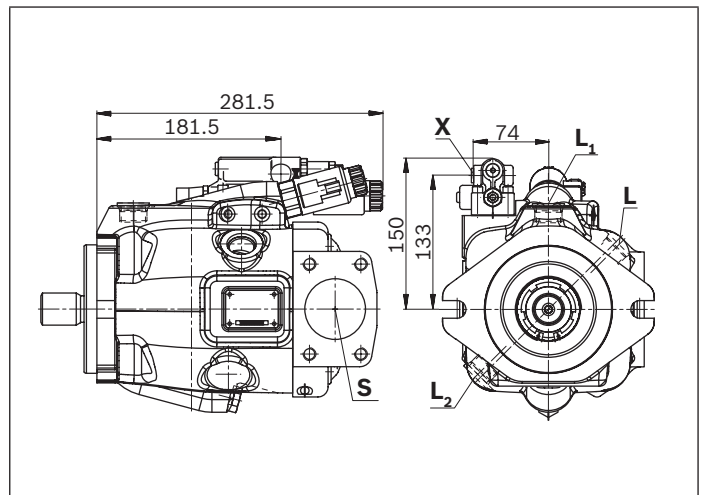

▼ **LA.D. – Pressure, flow and power controller, series 53**

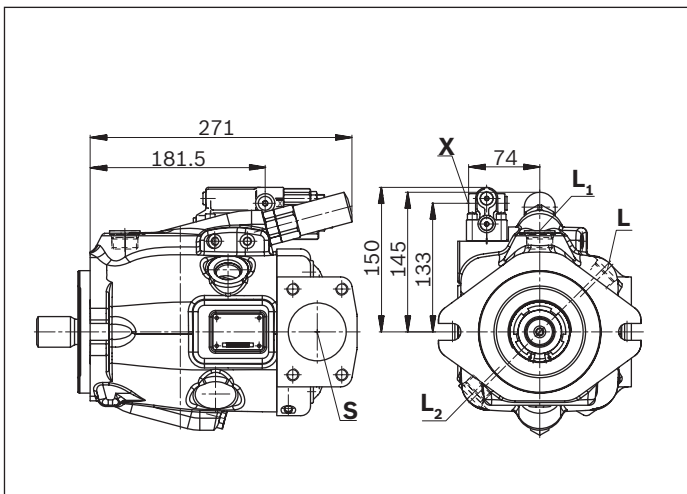

▼ **ED7. / ER7. – Electro-prop. pressure control, series 53**

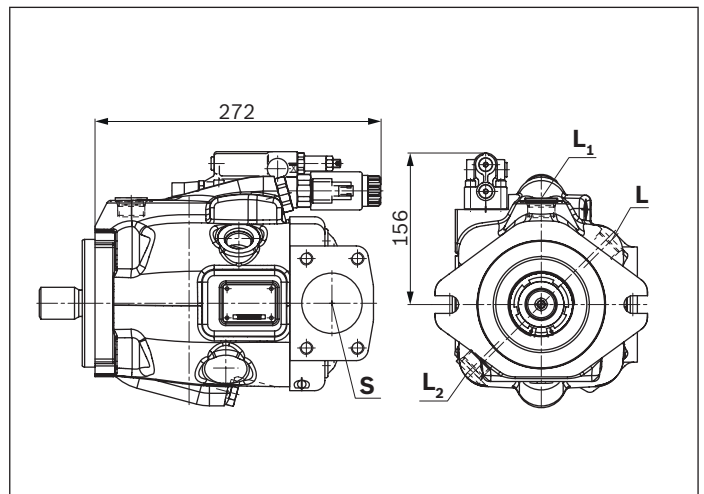

Dimensions, through drive

Flange ISO 3019-1 (SAE)		Hub for splined shaft ¹⁾		Availability across sizes						Code	
Diameter	Mounting ²⁾	Diameter		18	28	45	60/63	72	85		100
82-2 (A)	ø ² , ∞	5/8 in	9T 16/32DP	●	●	●	●	●	●	●	K01
		3/4 in	11T 16/32DP	●	●	●	●	●	●	●	K52

● = Available ○ = On request - = Not available

▼ 82-2

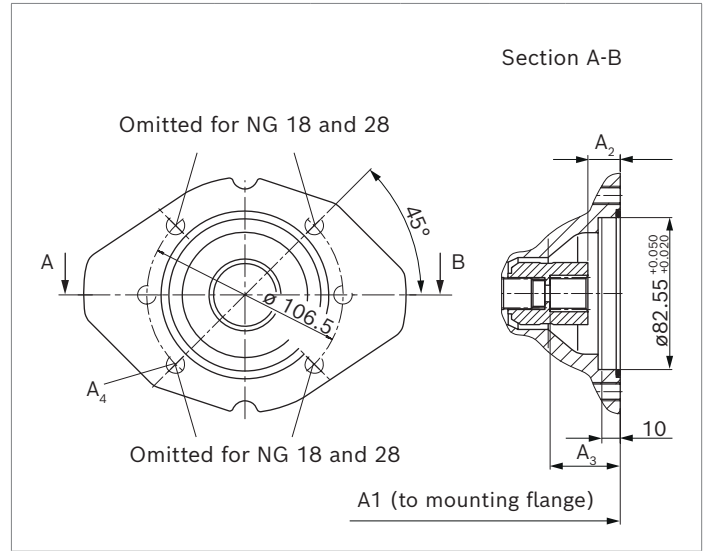
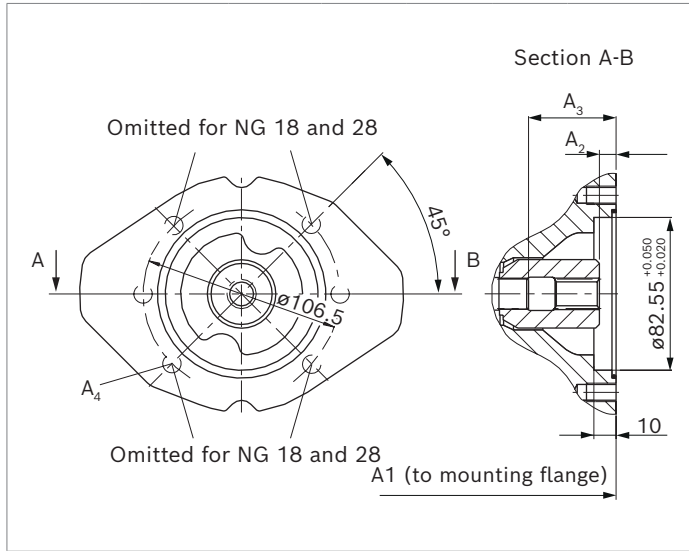

K01 (SAE J744 16-4 (A))	NG	A1	A2 ⁴⁾	A3 ⁴⁾	A4 ³⁾⁵⁾
18	182 (7.17)	182 (7.17)	9.3 (0.37)	42.5 (1.67)	M10 × 1.5; 14.5 (0.57) deep
28	204 (8.03)	204 (8.03)	9.2 (0.36)	36.2 (1.43)	M10 × 1.5; 16 (0.63) deep
45	229 (9.02)	229 (9.02)	10 (0.39)	52.7 (2.07)	M10 × 1.5; 16 (0.63) deep
60/ 63	255 (10.04)	255 (10.04)	8.7 (0.34)	58.2 (2.29)	M10 × 1.5; 16 (0.63) deep
72	255 (10.04)	255 (10.04)	8.7 (0.34)	58.2 (2.29)	M10 × 1.5; 16 (0.63) deep
85	302 (11.89)	302 (11.89)	12.5 (0.49)	67.2 (2.65)	M10 × 1.5; 20 (0.79) deep
100	302 (11.89)	302 (11.89)	12.5 (0.49)	67.2 (2.65)	M10 × 1.5; 20 (0.79) deep

K52 (SAE J744 19-4 (A-B))	NG	A1	A2 ⁴⁾	A3 ⁴⁾	A4 ³⁾⁵⁾
18	182 (7.17)	182 (7.17)	18.3 (0.71)	39.3 (1.54)	M10 × 1.5; 14.5 (0.57) deep
28	204 (8.03)	204 (8.03)	18.4 (0.72)	39.4 (1.55)	M10 × 1.5; 16 (0.63) deep
45	229 (9.02)	229 (9.02)	18.4 (0.72)	38.8 (1.53)	M10 × 1.5; 16 (0.63) deep
60/ 63	255 (10.04)	255 (10.04)	18.4 (0.72)	38.8 (1.53)	M10 × 1.5; 16 (0.63) deep
72	255 (10.04)	255 (10.04)	18.4 (0.72)	38.8 (1.53)	M10 × 1.5; 16 (0.63) deep
85	302 (11.89)	302 (11.89)	21.5 (0.85)	42.5 (1.67)	M10 × 1.5; 20 (0.79) deep
100	302 (11.89)	302 (11.89)	21.5 (0.85)	42.5 (1.67)	M10 × 1.5; 20 (0.79) deep

1) According to ANSI B92.1a, 30° pressure angle, flat root, side fit, tolerance class 5

2) Mounting holes pattern viewed on through drive with control at top

3) Thread according to DIN 13.

4) Minimum dimensions

5) Design recommended according to VDI 2230, screw quality 8.8 according to ISO 898-1

Flange ISO 3019-1 (SAE)		Hub for splined shaft ¹⁾		Availability across sizes						Code	
Diameter	Mounting ²⁾	Diameter		18	28	45	60/63	72	85	100	
101-2 (B)	⌀, ∞	7/8 in	13T 16/32DP	-	●	●	●	●	●	●	K68
		1 in	15T 16/32DP	-	-	●	●	●	●	●	K04

● = Available ○ = On request - = Not available

▼ 101-2

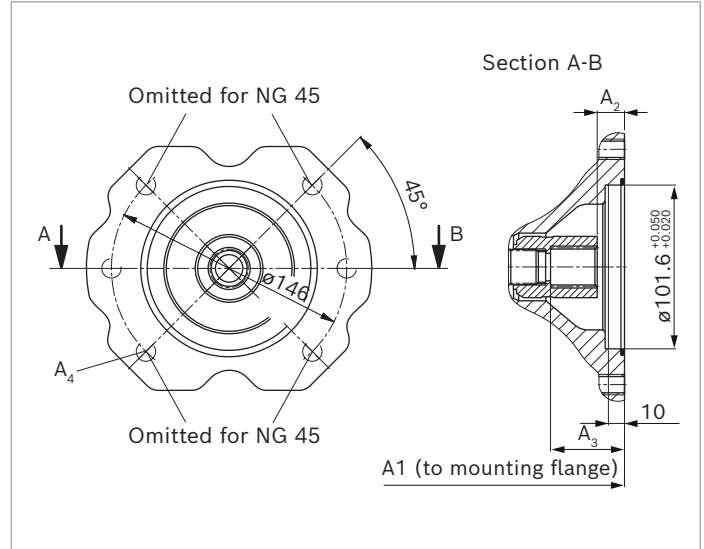
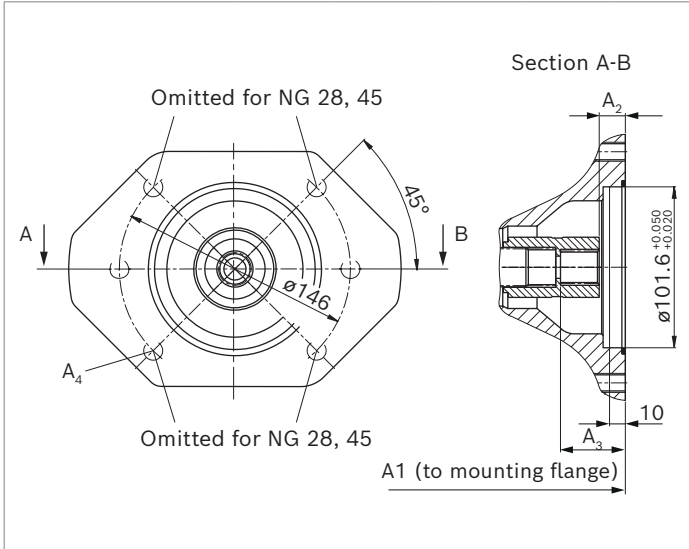

K68 (SAE J744 22-4 (B))	NG	A1	A2 ⁴⁾	A3 ⁴⁾	A4 ³⁾
	28	204 (8.03)	17.4 (0.68)	42.4 (1.67)	M12 × 1.75; 18 (0.71) deep
	45	229 (9.02)	17.4 (0.68)	41.8 (1.65)	M12 × 1.75; 18 (0.71) deep
	60/ 63	255 (10.04)	17.4 (0.68)	41.8 (1.65)	M12 × 1.75; 18 (0.71) deep
	72	255 (10.04)	17.4 (0.68)	41.8 (1.65)	M12 × 1.75; 18 (0.71) deep
	85	302 (11.89)	20.5 (0.81)	44.8 (1.76)	M12 × 1.75; 20 (0.79) deep
	100	302 (11.89)	20.5 (0.81)	44.8 (1.76)	M12 × 1.75; 20 (0.79) deep

K04 (SAE J744 25-4 (B-B))	NG	A1	A2 ⁴⁾	A3 ⁴⁾	A4 ³⁾⁵⁾
	45	229 (9.02)	17.9 (0.70)	47.4 (1.87)	M12 × 1.75; 18 (0.71) deep
	60/ 63	255 (10.04)	17.9 (0.70)	46.8 (1.84)	M12 × 1.75; 18 (0.71) deep
	72	255 (10.04)	17.9 (0.70)	46.8 (1.84)	M12 × 1.75; 18 (0.71) deep
	85	302 (11.89)	20.7 (0.81)	49.5 (1.95)	M12 × 1.75; 20 (0.79) deep
	100	302 (11.89)	20.7 (0.81)	49.5 (1.95)	M12 × 1.75; 20 (0.79) deep

1) According to ANSI B92.1a, 30° pressure angle, flat root, side fit, tolerance class 5

2) Mounting holes pattern viewed on through drive with control at top

3) Thread according to DIN 13.

4) Minimum dimensions

5) Design recommended according to VDI 2230, screw quality 8.8 according to ISO 898-1

Flange ISO 3019-1 (SAE)		Hub for splined shaft ¹⁾		Availability across sizes						Code	
Diameter	Mounting ²⁾	Diameter		18	28	45	60/63	72	85	100	
127-4 (C)		1 1/4 in	14T 12/24DP	-	-	-	●	●	●	●	K15
		1 1/2 in	17T 12/24DP	-	-	-	-	-	●	●	K16

● = Available ○ = On request - = Not available

▼ **127-4**

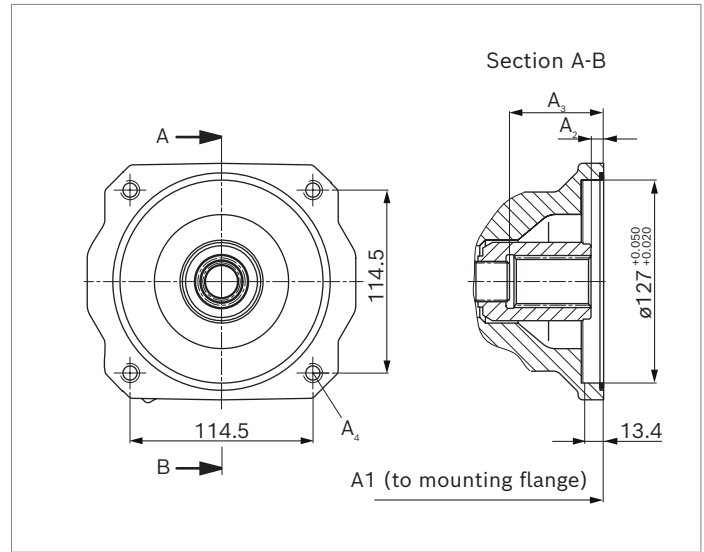
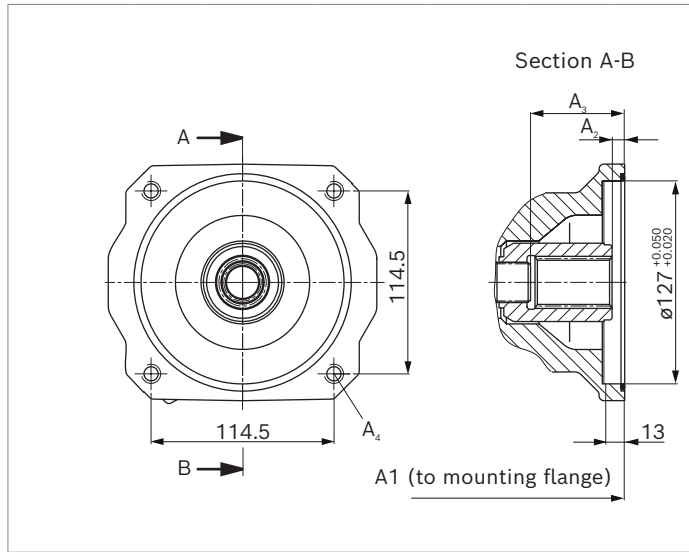

K15	NG	A1	A2 ⁴⁾	A3 ⁴⁾	A4 ³⁾⁵⁾
(SAE J744 32-4 (C))					
60/	255	17.9	55.9	M12 × 1.75;	
63	(10.04)	(0.70)	(0.20)	16 (0.63) deep	
72	255	17.9	55.9	M12 × 1.75;	
	(10.04)	(0.70)	(0.20)	16 (0.63) deep	
85	301.5	22	60	M12 × 1.75;	
	(11.87)	(0.87)	(2.36)	through	
100	301.5	22	60	M12 × 1.75;	
	(11.87)	(0.87)	(2.36)	through	

K16	NG	A1	A2 ⁴⁾	A3 ⁴⁾	A4 ³⁾⁵⁾
(SAE J744 32-4 (C))					
85	301.5	12.8	67.2	M12 × 1.75;	
	(11.87)	(0.50)	(2.65)	through	
100	301.5	12.8	67.2	M12 × 1.75;	
	(11.87)	(0.50)	(2.65)	through	

1) According to ANSI B92.1a, 30° pressure angle, flat root, side fit, tolerance class 5

2) Mounting holes pattern viewed on through drive with control at top

3) Thread according to DIN 13.

4) Minimum dimensions

5) Design recommended according to VDI 2230, screw quality 8.8 according to ISO 898-1

Flange ISO 3019-1 (SAE)		Hub for splined shaft ¹⁾		Availability across sizes						Code	
Diameter	Mounting ²⁾	Diameter		18	28	45	60/63	72	85	100	
127-2 (B)	♂, ∞	1 1/4 in	14T 12/24DP	-	-	-	-	-	•	•	K07
		1 1/2 in	17T 12/24DP	-	-	-	-	-	•	•	K24

• = Available ◦ = On request - = Not available

▼ 127-2

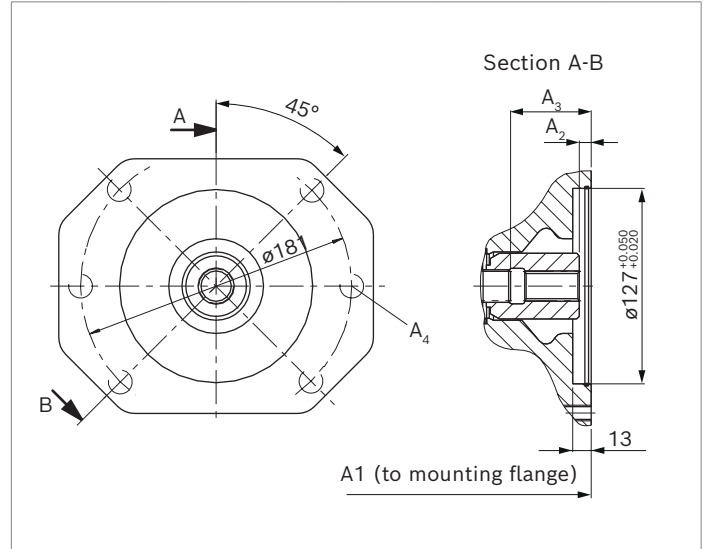
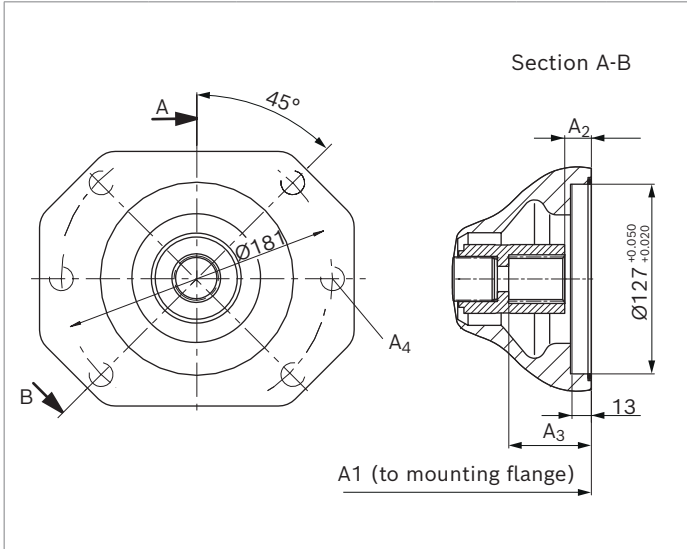

K07 (SAE J744 32-4 (C))	NG	A1	A2 ⁴⁾	A3 ⁴⁾	A4 ³⁾⁵⁾
	85	301.5 (11.87)	22 (0.87)	60 (2.36)	M16×2; 24 (0.94) deep
	100	301.5 (11.87)	22 (0.87)	60 (2.36)	M16×2; 24 (0.94) deep

K24 (SAE J744 38-4 (C-C))	NG	A1	A2 ⁴⁾	A3 ⁴⁾	A4 ³⁾⁵⁾
	85	302 (11.89)	12.8 (0.50)	67.2 (2.65)	M16×2; 24 (0.94) deep
	100	302 (11.89)	12.8 (0.50)	67.2 (2.65)	M16×2; 24 (0.94) deep

1) According to ANSI B92.1a, 30° pressure angle, flat root, side fit, tolerance class 5

2) Mounting holes pattern viewed on through drive with control at top

3) Thread according to DIN 13.

4) Minimum dimensions

5) Design recommended according to VDI 2230, screw quality 8.8 according to ISO 898-1

Overview of mounting options

Through drive			Mounting options – 2nd pump				
Flange ISO 3019-1	Hub for splined shaft	Code	A10VO/5x NG (shaft)	A10VO/60 NG (shaft)	A10VO/31 NG (shaft)	A1VO/10 NG (shaft)	External gear pump
82-2 (A)	5/8 in	K01	10 (U), 18 (U)	–	18 (U)	18, 28 (S2)	AZPF
	3/4 in	K52	10 (S), 18 (S, R)	–	18 (S, R)	18, 28 (S3)	
101-2 (B)	7/8 in	K68	28 (S, R) 45 (U, W) ¹⁾	45 (S4)	28 (S, R) 45 (U, W)	35 (S4)	AZPN/AZPG
	1 in	K04	45 (S, R) 60, 63 (U, W) ²⁾ 72 (U, W) ²⁾	45 (S5)	45 (S, R)	35 (S5)	–
127-4 (C)	1 1/4 in	K15	60, 63 (S, R) 72 (S, R)	–	–	–	–
	1 1/2 in	K16	85 (S) 100 (S)	–	–	–	–
127-2 (C)	1 1/4 in	K07	85 (U) 100 (U)	–	71 (S, R)	–	PGH5
	1 1/2 in	K24	85 (S) 100 (S)	–	–	–	–

1) Not for NG28 with K68

2) Not for NG45 with K04

Combination pumps A10VO + A10VO

By using combination pumps, it is possible to have independent circuits without the need for splitter gearboxes. When ordering combination pumps the type designations for the first and the second pump must be joined by a "+" and are combined into one part number. Each single pump should be ordered according to type code.

Notice

- ▶ The combination pump type code is shown in shortened form in the order confirmation.
- ▶ Each through drive is plugged with a **non-pressure-resistant** cover. This means the units must be sealed with a pressure-resistant cover before commissioning.

Order example:

A10VO85DRS/53R-VSC12K04+

A10VO45DRG/53R-VSC11N00

A tandem pump, with two pumps of equal size, is permissible without additional supports, assuming that the dynamic mass acceleration does not exceed maximum 10 g (= 98.1 m/s²).

For combination pumps consisting of more than two pumps, the mounting flange must be rated for the permissible mass torque (please contact us).

Notice

Through drives with installed hub are supplied with a spacer.
 The spacer must be removed before installation of the 2nd pump and before commissioning. For further information, see the operating instructions 92703-01-B

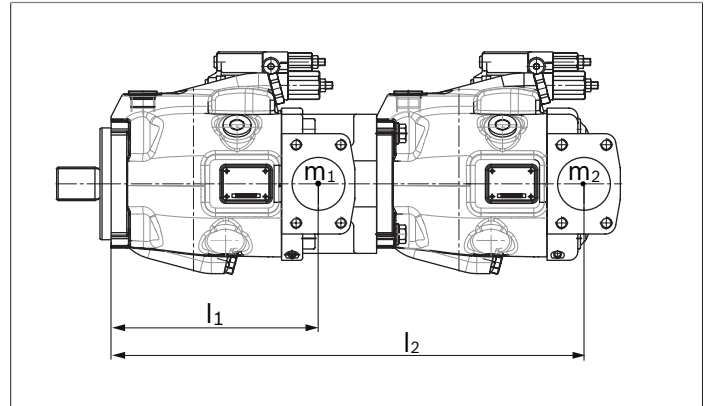

m_1, m_2, m_3	Weight of pump	[kg (lbs)]
l_1, l_2, l_3	Distance from center of gravity	[mm (inch)]
$M_m = (m_1 \times l_1 + m_2 \times l_2 + m_3 \times l_3) \times \frac{1}{102 (12)} \text{ [Nm (lb-ft)]}$		

Permissible moments of inertia

NG			10	18	28	45	60/63	72	85	100
Static	M_m	Nm	–	500	890	900	1370	1370	3080	3080
		lb-ft	–	369	656	664	101	101	2270	2270
Dynamic at 10 g (98.1 m/s ²)	M_m	Nm	–	50	89	90	137	137	308	308
		lb-ft	–	37	65	66	101	101	227	227
Weight without through-drive plate (e.g. 2nd pump)	m	kg	8	11.5	15	18	22	22	36	36
		lb-ft	18	25	33	40	49	49	79	79
Weight with through-drive plate	m	kg	–	13	18	24	28	28	45	45
		lb-ft	–	29	40	53	62	62	99	99
Distance, center of gravity without through drive	l_1	mm	–	78	85	96	105	105	122	122
		inch	–	3.07	3.35	3.78	4.13	4.13	4.80	4.80
Distance, center of gravity with through drive	l_1	mm	–	87	99	115	127	127	150	150
		inch	–	3.43	3.90	4.53	5.00	5.00	5.90	5.90

Connector for solenoids

DEUTSCH DT04-2P

Molded, 2-pin, without bidirectional suppressor diode.

There is the following type of protection with the mounted mating connector:

- ▶ IP67 (DIN/EN 60529) and
- ▶ IP69K (DIN 40050-9)

▼ Switching symbol

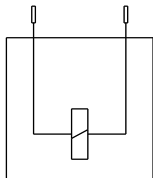

▼ Mating connector DEUTSCH DT06-2S-EP04

Consisting of	DT designation
1 housing	DT06-2S-EP04
1 wedge	W2S
2 sockets	0462-201-16141

The mating connector is not included in the scope of delivery. This can be supplied by Bosch Rexroth on request (material number R902601804).

Notice

- ▶ If necessary, you can change the position of the connector by turning the solenoid body. The procedure is defined in the operating instructions 92703-01-B.
- ▶ Only the dead weight (<1 N (0.22 lbf)) of the connection cable with a length of 150 mm (5.91 inch) may act on the plug-in connection and the solenoid coil with coil nut. Other forces and vibrations are not permissible. This can be realized e.g. by suspension of the cable at the same vibration system.

Swivel angle sensor

Description

The swivel angle sensor PAL is used for contactless detection of the swivel angle of axial piston units using a Hall effect-based sensor IC. The measured position is converted into electric signals by the redundant swivel angle sensor.

Technical data and safety instructions for the sensor are provided in the relevant data sheet 95161.

Features

- ▶ High temperature stability of the output signal
- ▶ Shock and vibration resistance
- ▶ Integrated electronic fault detection
- ▶ CE conformity

▼ Output characteristic at pin 4, code H

Swivel angle sensor counter-clockwise installation with view of the shaft, control valve top

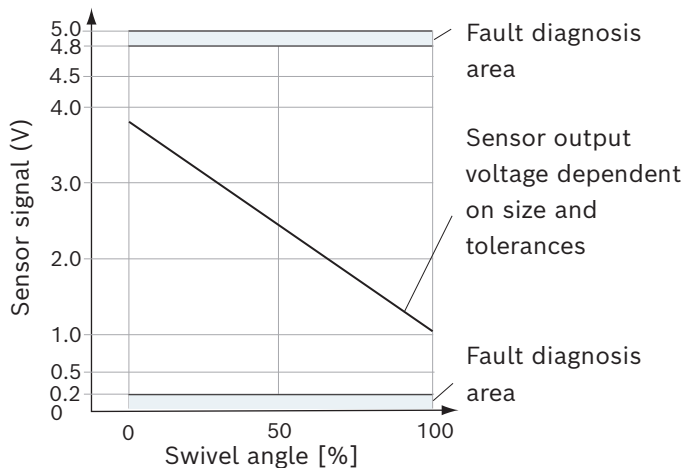

Pin assignment

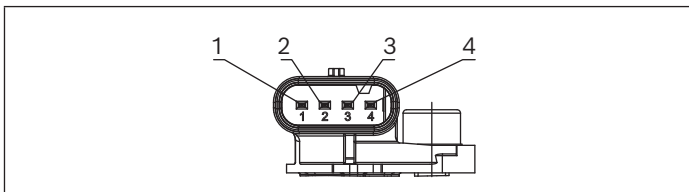

▼ Pin assignment analog ratiometric/PWM (order code H)

PAL 2 312A340 CM/10F

(for further information, see data sheet 95161)

Pin	Connection
1	Sensor signal 2 PWM (active-high; 5 ... 95% on time)
2	Supply voltage U_{supply}
3	Weight GND
4	Sensor signal 1 Analog ratiometric (10 ... 90% U_{supply})

▼ Permissible PAL variants

Output signal	Type	Code
Analog ratiometric/PWM	PAL 2 312A340 CM/10F	H
SENT/SENT	PAL 2 312A340 SM/10F	P

Characteristic

Supply voltage U_{supply}	5 VDC
Maximum supply voltage range U_{supply}	4.5 ... 5.5 VDC
Overvoltage range for 48 h	28 VDC
Overvoltage range for 60 sec ($\tau_{amb} < 35\text{ °C}$ (95 °F))	37 VDC
Current consumption (I_{DD})	20 to 27 mA
Load resistance	see data sheet 95161
Reverse polarity protection (48h/60sec)	-14 VDC/-18 VDC
Operating temperature	-40 °C (-40 °F) to +125 °C (257 °F)
Type of protection ISO 20653 (with plugged mating connector and cable)	IPx9k, IP6kx, IPX6, and IPX7

Notice

- ▶ Information on environmental and EMC conditions on request.
- ▶ Painting the sensor with electrostatic charge is not permitted (danger: ESD damage)

▼ Pin assignment SENT/SENT (order code P)

PAL 2 312A340 SM/10F

(for further information, see data sheet 95161)

Pin	Connection
1	Sensor signal 2 SENT format H.1 (two 12-bit fast channels)
2	Supply voltage U_{supply}
3	Weight GND
4	Sensor signal 1 SENT format H.4 (12 bit fast channel and single secure)

Mating connector

The mating connector is not included in the scope of delivery and can be ordered on request from Bosch Rexroth with the material number R917012863. For additional mating connector variants (for other cable diameters, among others), see data sheet 95161.

Installation instructions

General

The axial piston unit must be filled with hydraulic fluid and air bled during commissioning and operation.

This must also be observed following a longer standstill as the axial piston unit may empty via the hydraulic lines. Particularly with the "drive shaft up/down" installation position, filling and air bleeding must be carried out completely as there is e.g. a danger of dry running.

The leakage in the housing area must be directed to the reservoir via the highest positioned drain port (**L**, **L₁**, **L₂**). If a shared drain line is used for several units, make sure that the respective case pressure in each unit is not exceeded. The shared drain line must be dimensioned to ensure that the maximum permissible case pressure of all connected units is not exceeded in any operating condition, particularly at cold start. If this is not possible, separate drain line must be laid.

To prevent the transmission of structure-borne noise, use elastic elements to decouple all connecting lines from all vibration-capable components (e.g., reservoir, frame parts). Under all operating conditions, the suction lines and the drain lines must flow into the reservoir below the minimum fluid level. The permissible suction height h_s results from the total pressure loss. However, it must not be higher than $h_{s \max} = 800 \text{ mm}$ (31.5 inch). The minimum suction pressure at port **S** must not fall below 0.8 bar (12 psi) absolute during operation and during cold start. When designing the reservoir, ensure that there is adequate distance between the suction line and the drain line. We recommend using a baffle (baffle plate) between suction line and drain line. A baffle improves the air separation ability as it gives the hydraulic fluid more time for desorption. Additionally, this prevents the heated return flow from being drawn directly back into the suction line. The suction port must be supplied with air-free, calmed and cooled hydraulic fluid.

Notice

In certain installation positions, an influence on the adjustment or control can be expected. Gravity, dead weight and case pressure can cause minor characteristic shifts and changes in actuating time.

Installation position

See the following examples **1** to **12**.

Further installation positions are available upon request.

Recommended installation positions: **1** and **3**

Key	
F	Filling / Air bleeding
S	Suction port
L; L₁; L₂	Drain port
SB	Baffle (baffle plate)
$h_{t \min}$	Minimum required immersion depth (200 mm (7.87 inch))
h_{\min}	Minimum required distance to reservoir bottom (100 mm (3.94 inch))
$h_{ES \min}$	Minimum height required to prevent axial piston unit from draining (25 mm (0.98 inch))
$h_{S \max}$	Maximum permissible suction height (800 mm (21.50 inch))

Notice

Port **F** is part of the external piping and must be provided on the customer side to make filling and air bleeding easier.

Below-reservoir installation (standard)

Below-reservoir installation means that the axial piston unit is installed outside of the reservoir below the minimum fluid level.

▼ **Installation position 1**

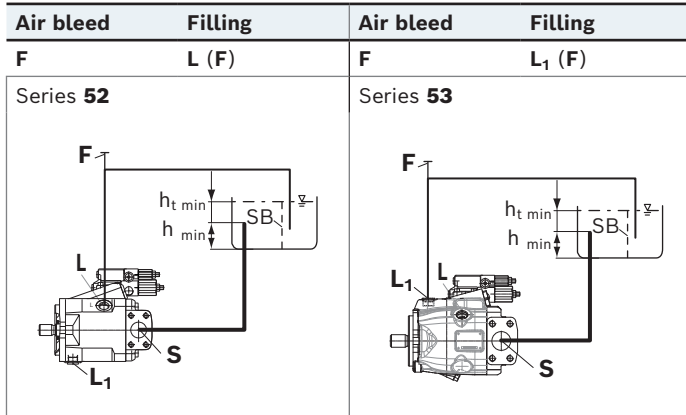

▼ **Installation position 4**

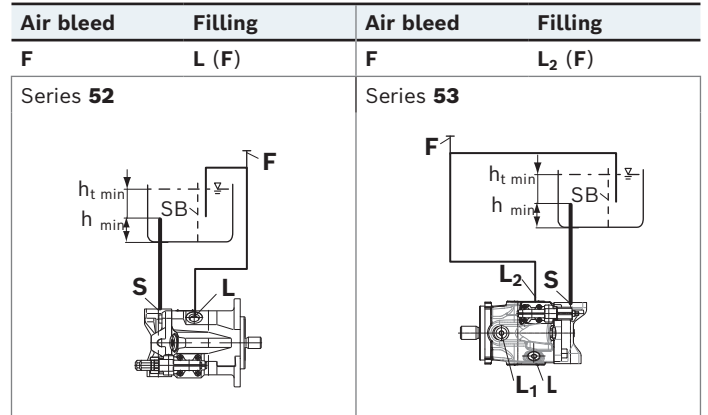

▼ **Installation position 2¹⁾**

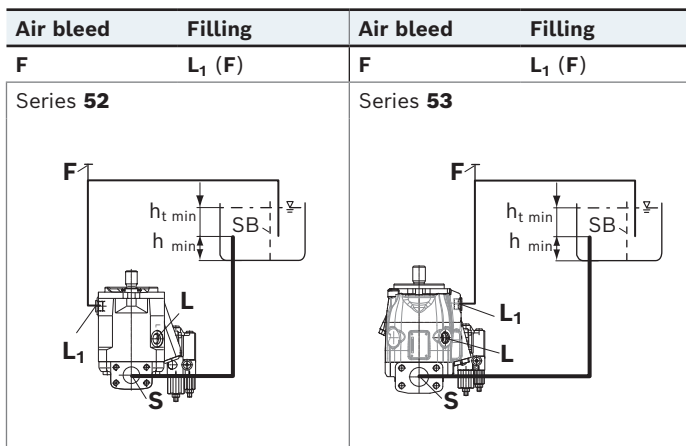

▼ **Installation position 3¹⁾**

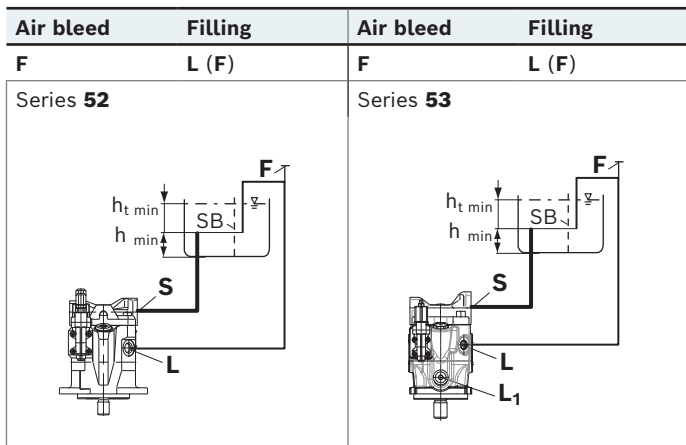

For key, see page 80.

¹⁾ Because complete air bleeding and filling are not possible in this position, the pump should be air bled and filled in a horizontal position before installation.

Above-reservoir installation

Above-reservoir installation means that the axial piston unit is installed above the minimum fluid level of the reservoir. To prevent the axial piston unit from draining, a height difference $h_{ES\ min}$ of at least 25 mm (0.98 inch) is required in position 6. Observe the maximum permissible suction height $h_{S\ max} = 800$ mm (31.50 inch).

A check valve in the case drain line is only permissible in individual cases. Consult us for approval.

For key, see page 80.

▼ **Installation position 5**

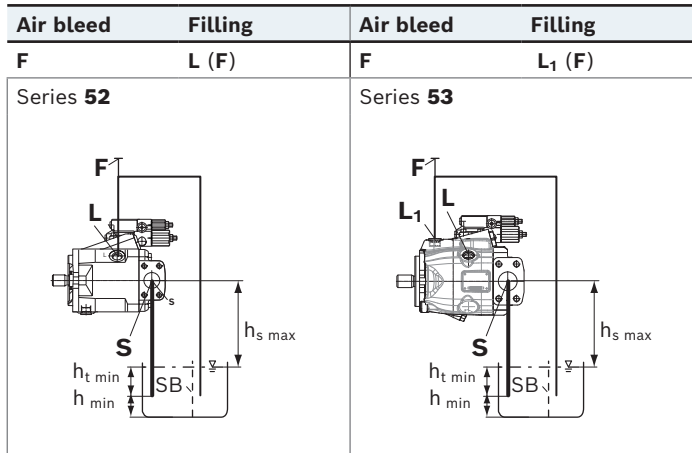

▼ **Installation position 8**

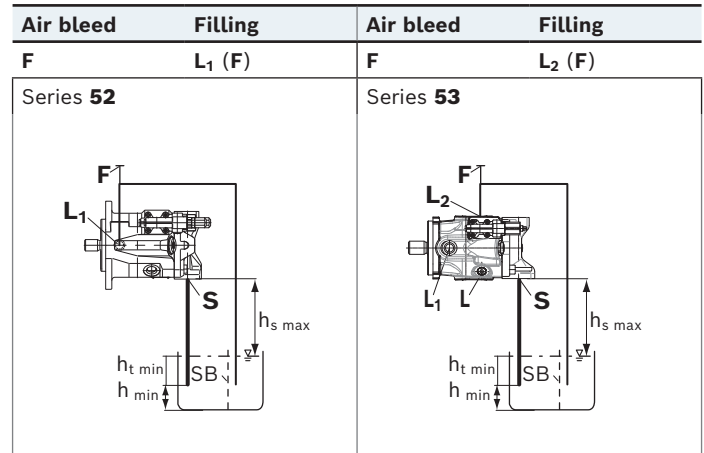

▼ **Installation position 6¹⁾**

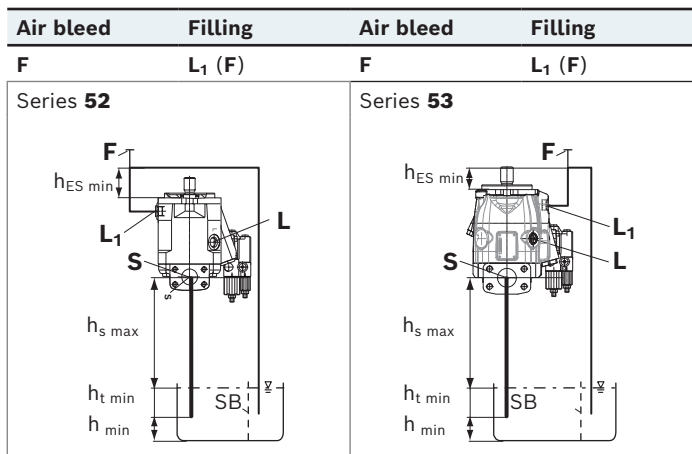

▼ **Installation position 7¹⁾**

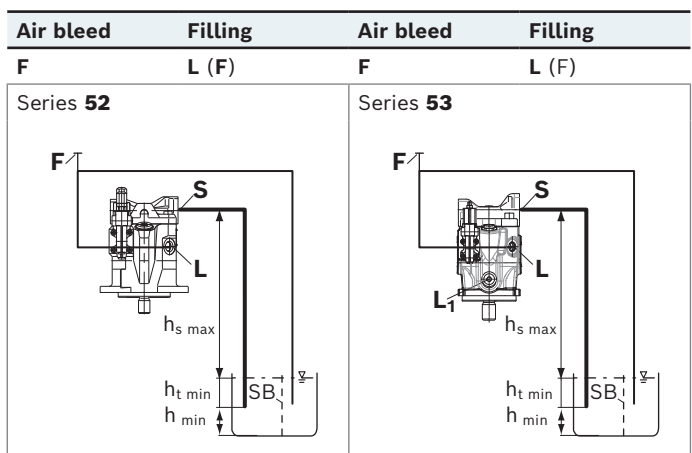

1) Because complete air bleeding and filling are not possible in this position, the pump should be air bled and filled in a horizontal position before installation.

Inside-reservoir installation

Inside-reservoir installation is when the axial piston unit is installed in the reservoir below the minimum fluid level. The axial piston unit is completely below the hydraulic fluid.

If the minimum fluid level is equal to or below the upper edge of the pump, see chapter "Above-reservoir installation".

Axial piston units with electrical components (e.g. electric control, sensors) may not be installed in a reservoir below the fluid level.

▼ **Installation position 9**

Air bleed	Filling	Air bleed	Filling
L	L	L ₁	L ₁
<p>Series 52</p>		<p>Series 53</p>	

▼ **Installation position 10¹⁾**

Air bleed	Filling	Air bleed	Filling
L ₁	L ₁	L ₁	L ₁
<p>Series 52</p>		<p>Series 53</p>	

▼ **Installation position 11¹⁾**

Air bleed	Filling	Air bleed	Filling
L	L	L	L
<p>Series 52</p>		<p>Series 53</p>	

For key, see page 80.

Notice

- Our advice is to fit a suction pipe to the suction port **S** and to fit a pipe to case drain port **L**, **L₁** or **L₂**. In this case, the other drain port must be plugged. The housing of the axial piston unit is to be filled via **L**, **L₁** or **L₂** (see installation position 9 to 12) before the pipework is fitted and the reservoir is filled with hydraulic fluid.

▼ **Installation position 12**

Air bleed	Filling	Air bleed	Filling
L ₁	L ₁	L ₂	L ₂
<p>Series 52</p>		<p>Series 53</p>	

¹⁾ Because complete air bleeding and filling are not possible in this position, the pump should be air bled and filled in a horizontal position before installation.

Project planning notes

- ▶ The A10VO axial piston variable pump is intended to be used in an open circuit.
- ▶ The project planning, installation and commissioning of the axial piston unit requires the involvement of skilled personnel.
- ▶ Before using the axial piston unit, please read the corresponding operating instructions completely and thoroughly. If necessary, this can be requested from Bosch Rexroth.
- ▶ Before finalizing your design, please request a binding installation drawing.
- ▶ The specified data and notes contained herein must be observed.
- ▶ Depending on the operating conditions of the axial piston unit (working pressure, fluid temperature), the characteristic curve may shift. The characteristic curve may also shift due to the dither frequency or control electronics.
- ▶ Preservation: Our axial piston units are supplied as standard with preservation protection for a maximum of 12 months. If longer preservation protection is required (maximum 24 months), please specify this in plain text when placing your order. The preservation periods apply under optimal storage conditions, details of which can be found in the data sheet 90312 or the operating instructions.
- ▶ Not all configuration variants of the product are approved for use in safety functions according to ISO 13849. Please consult the proper contact at Bosch Rexroth if you require reliability parameters (e.g., $MTTF_d$) for functional safety.
- ▶ Depending on the type of control used, electromagnetic effects can be produced when using solenoids. Applying a direct voltage signal (DC) to solenoids does not create electromagnetic interference (EMI) nor is the solenoid affected by EMI. Electromagnetic interference (EMI) potential exists when operating and controlling a solenoid with a modulated direct voltage signal (e.g. PWM signal). Appropriate testing and measures should be taken by the machine manufacturer to ensure other components or operators (e.g. with pacemaker) are not affected by this potential.
- ▶ The pressure control (hydraulic or electronic) is not an adequate safeguard against pressure overload. Therefore, a pressure relief valve must be added to the hydraulic system (integrated into the pump or externally in the system). In this connection, observe the technical limits of the pressure relief valve.
- ▶ Please note that a hydraulic system is an oscillating system. This can lead, for example, to the stimulation the natural frequency within the hydraulic system during operation at constant rotational speed over a long period of time. The excitation frequency of the pump is 9 times the rotational speed frequency. This can be prevented, for example, with suitably designed hydraulic lines.
- ▶ Please note the information regarding the tightening torques of connection threads and other screw connections in the operating instructions.
- ▶ The ports and fastening threads are designed for the p_{max} permissible pressures of the respective ports, see the connection tables. The machine or system manufacturer must ensure that the connecting elements and lines correspond to the specified application conditions (pressure, flow, hydraulic fluid, temperature) with the necessary safety factors.
- ▶ The service ports and function ports are only intended to accommodate hydraulic lines.

Safety instructions

- ▶ During and shortly after operation, there is a risk of getting burnt on the axial piston unit and especially on the solenoids. Take the appropriate safety measures (e.g. by wearing protective clothing).
- ▶ Moving parts in control equipment (e.g. valve spools) can, under certain circumstances, get stuck in position as a result of contamination (e.g. contaminated hydraulic fluid, abrasion, or residual dirt from components). As a result, the hydraulic fluid flow and the build-up of torque in the axial piston unit can no longer respond correctly to the operator's specifications. Even the use of various filter elements (external or internal flow filtration) will not rule out a fault but merely reduce the risk.

The machine/system manufacturer must test whether remedial measures are needed on the machine for the application concerned in order to bring the driven consumer into a safe position (e.g. safe stop) and ensure any measures are properly implemented.

Related documentation

Product-specific documentation

Document type	Title	Document number
Data sheet	Hall effect swivel angle and linear position sensor PAL2/20	95161
	Application software eOC BODAS pump control	95345
	BODAS controller RC5-6 series 40	95207
	BODAS controller RC18-12 series 40, RC27-18 series 40	95208
	Load-sensing control block M4-12	64276
	Load-sensing control block M4-15	64283
	Flow sharing control block in mono block/sandwich plate design M7-22	64295
	Storage and preservation of axial piston units	90312
Operating instructions	Axial piston variable pump A10VO, A10VSO, A10VNO, A10VSNO series 52 and 53	92703-01-B

Documentation for hydraulic fluids

Document type	Title	Document number
Data sheet	Hydraulic fluids based on mineral oils and related hydrocarbons	90220
	Environmentally acceptable hydraulic fluids	90221
	Rating of hydraulic fluids used in Rexroth hydraulic components (pumps and motors)	90235
	Bosch Rexroth Fluid Rating List for Rexroth hydraulic components (pumps and motors)	90245

Bosch Rexroth AG

An den Kelterwiesen 14
 72160 Horb a.N.
 Germany
 Phone +49 7451 92-0
sales.mobile.horb@boschrexroth.de
www.boschrexroth.com

Bosch Rexroth Corporation

8 Southchase Court
 Fountain Inn, SC 29644-9018
 USA
 Phone (864) 967-2777
 Fax (864) 967-8900
www.boschrexroth-us.com

Bosch Rexroth Corporation

2315 City Line Road
 Bethlehem, PA 18017-2131,
 USA
 Phone (610) 694-8300
 Fax (610) 694-8467
www.boschrexroth-us.com

© Bosch Rexroth AG 1991. All rights reserved, also regarding any disposal, exploitation, reproduction, editing, distribution, as well as in the event of applications for industrial property rights. The data specified within only serve to describe the product. As our products are constantly being further developed, no statements concerning a certain condition or suitability for a certain application can be derived from our information. The information given does not release the user from the obligation of own judgment and verification. It must be remembered that our products are subject to a natural process of wear and aging.